

# MODEL E TECHNICAL SPECIFICATION



## ADDRESS AND CONTACT DATA

Heatex AB  
Hyllie Boulevard 34  
S-215 32 MALMÖ  
Sweden

Telephone: +46 410 710 500  
info@heatex.com  
[www.heatex.com](http://www.heatex.com)

## DISCLAIMER

Information in this document (including URL references and information from other external sources referred herein) is subject to change without notice. Owing to continued product development, Heatex reserves the right to introduce alterations in both design and prices without prior notice.

THIS DOCUMENT IS PROVIDED "AS IS" WITH NO EXPRESSED OR IMPLIED WARRANTIES WHATSOEVER, INCLUDING ANY WARRANTY OF MERCHANTABILITY, NON-INFRINGEMENT, FITNESS FOR ANY PARTICULAR PURPOSE, OR OTHERWISE ANY WARRANTY ARISING OUT OF ANY PROPOSAL, SPECIFICATION OR SAMPLE. ALL LIABILITY, INCLUDING LIABILITY FOR INFRINGEMENT OF ANY PROPRIETARY RIGHTS, RELATING TO USE OF INFORMATION CONTAINED OR REFERENCED IN THIS DOCUMENT IS HEREBY EXPRESSLY DISCLAIMED.

## COPYRIGHT NOTICE

All information and content included (whether directly or by reference) in this document, such as text, graphics and images, is the property of Heatex AB, its subsidiaries, affiliates, licensors and/or joint venture partners. All rights are reserved.

No licenses, express, implied or otherwise to any intellectual property rights in this document are granted by Heatex AB.

This disclaimer and copyright notice is subject to and governed by Swedish law.

Copyright © 2021

Heatex AB

## Table of Contents

ADDRESS AND CONTACT DATA .....	2
DISCLAIMER .....	2
COPYRIGHT NOTICE .....	2
Table of Contents .....	3
1. GENERAL INFORMATION .....	4
2. WHEEL .....	4
2.1. Matrix Material .....	4
2.3. Wheel Construction .....	5
3. CASING AND CASING COMPONENTS .....	6
3.1. Casing Types.....	6
3.2. Casing Material .....	8
3.3. Drive Units .....	8
4. TECHNICAL INFORMATION .....	14
4.1. Application Limits .....	14
4.2. Freezing .....	15
4.3. Condensation.....	16
4.4. Wheel Protection.....	16
4.5. Heatex Select.....	16
4.6. Fan Positioning .....	17
4.7. Rotor Positioning .....	18
5. SUPPORT .....	19
5.1. Installation and Maintenance Manual.....	19
5.2. Name Description .....	19
5.3. Design Options .....	21
5.4. Definition Description.....	22

## 1. GENERAL INFORMATION

The rotary heat exchanger (RHE) consists of a rotating wheel, casing and drive unit. As the wheel rotates slowly, the heat from the exhaust air is picked up by the aluminum in the matrix and transferred to the cool supply air. Rotary heat exchangers are often the preferred choice thanks to the low freezing risk as the wheels by definition defrost themselves, their small footprint and the high sensible efficiency that they provide. The possibility of adding coating to the wheel, which allows latent transfer, is another factor favoring these products.

All Heatex heat exchangers are made to measure to fit the specific air handling unit and there is a wide variety of well heights to suit various performance requirements. Rotary heat exchangers can be equipped with a purge sector in order to minimize the cross contamination of fresh air with exhaust air.

Typical airflows for model E vary from 200 Nm<sup>3</sup>/h (125 SCFM) to approx. 90000 Nm<sup>3</sup>/h (56075 SCFM).

## 2. WHEEL

### 2.1. Matrix Material

#### Aluminum (Condensation)

The main use for an aluminum matrix is the transfer of temperature between the cold and the warm airflow. Moisture transfer will take place only if condensation occurs.

#### Epoxy Coated (Condensation)

The main use for an epoxy coated aluminum matrix is to protect the wheel from corrosive environments where an aluminum wheel would corrode easily otherwise. Heat and moisture transfer is as aluminum wheels.

#### Hybrid Coated (Enthalpy)

Hybrid materials consists of a corrugated aluminum foil combined with either a silica gel based coated flat aluminum foil or a molecular sieve based coated flat aluminum foil. The main use for a hybrid matrix is the enhanced moisture transfer compared to an aluminum matrix since moisture transfer will take place when the inlet moistures are different as well as when condensation occurs.

#### Silica Gel Coated (Adsorption)

Both corrugated and flat foils are coated with a silica gel coating that offers a high humidity efficiency in all environments.

#### Molecular Sieve Coated (Adsorption)

Both corrugated and flat foils are coated with a molecular sieve 3Å coating that offers a high humidity efficiency as well as protection against odours.

#### Hygromix Coated (Adsorption)

“Hygromix” is a combination of silica gel and molecular sieve coating. This combines the features of both coatings.



**NOTE!** The wheel should be kept clean to get the appropriate performance. See “Installation and Maintenance Manual” for further information.

## 2.2. Well Height (or Channel Height)

Heatex offers six different well heights for easy adaptation to the customer needs, all made from a unique set of tools to achieve optimal shape.

#### Well Height Version 1.4 mm (0.055”) – “Superior Efficiency”

1.4 mm (0.055”) well height provides an exceptional efficiency and, due to the high pressure drop, is used when the main focus is to achieve the highest possible efficiency.

#### Well Height Version 1.6 mm (0.063”) – “Very High Efficiency”

1.6 mm (0.063”) well height provides a very high efficiency due to its large heat transferring surface, but at the cost of a higher pressure drop.

#### Well Height Version 1.8 mm (0.071”) – “High Performance”

1.8 mm (0.071”) well height gives a good balance between a high efficiency and moderate pressure drop.

#### Well Height Version 2.0 mm (0.079”) – “Good Performance”

2.0 mm (0.079”) well height is a common configuration due to its good balance between efficiency and pressure drop.

#### Well Height Version 2.2 mm (0.087”) – “Standard Performance”

2.2 mm (0.087”) well height is used when low pressure drop is slightly more important than high efficiency.

### Well Height Version 2.5 mm (0.098”) – “Low Pressure Drop”

2.5 mm (0.098”) well height is used when low pressure drop is more important than high efficiency.

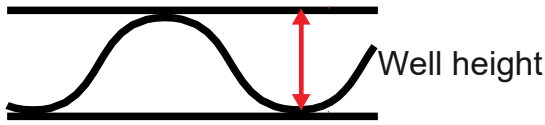

Figure 1. Well height.

Well height	Wave length
1.4 mm (0.055”)	2.6 mm (0.102”)
1.6 mm (0.063”)	3.0 mm (0.118”)
1.8 mm (0.071”)	3.4 mm (0.134”)
2.0 mm (0.079”)	3.8 mm (0.150”)
2.2 mm (0.086”)	4.8 mm (0.189”)
2.5 mm (0.098”)	4.8 mm (0.189”)

Table 1. Well height and its corresponding wave-length.

**NOTE!** Other types of definition can occur on the market.

## 2.3. Wheel Construction

In order to secure the strength of vertical wheels, spokes are glued to the matrix and welded in the hub and wrap. Depending on the size the amount of spokes vary to ensure the stability of the wheel.

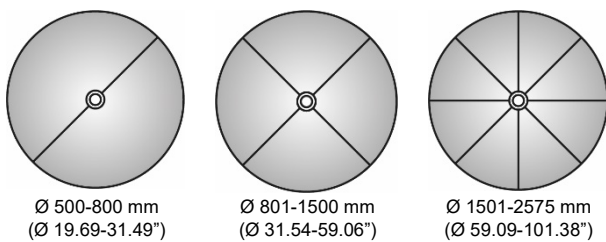

Figure 2. Spokes vertical wheels

The matrix of horizontal wheels is glued for extra strength and spokes are added as shown below.

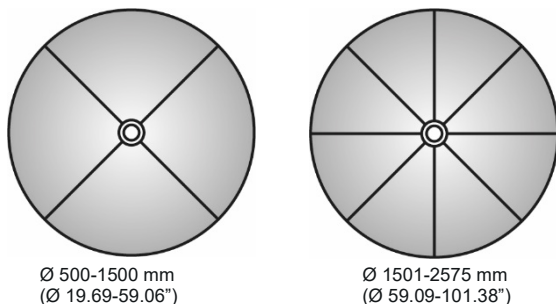

Figure 3. Spokes horizontal wheels.

### 2.3.1. Standard Shaft and Bearings

Heatex offers two different types of internal bearings: Deep groove standard ball bearings for vertical applications and angular contact bearings for wheels in horizontal applications.

The bearings are chosen for their low maintenance and long lifetime. Normal usage exceeds a period of 10 years. In a scenario with the toughest conditions (a 2575 mm (101.38”) wheel at constant 500Pa (2” WC) pressure difference) the estimated lifetime of the bearings should be above 55 000 hours (well over 6 years). The construction with internal bearings (well protected against dirt) is chosen for its long lifetime and will keep maintenance needs at a low level. Bearings can be replaced if necessary.

### 2.3.2. Corrosion Resistant Shaft and Bearings

Heatex offers, as a standard feature for epoxy coated wheels, corrosion resistant shaft and bearings in stainless steel EN 1.4404

### 3. CASING AND CASING COMPONENTS

The casing is made of rolled metal sheet and thus does not require maintenance. The casing comes in vertical or horizontal configuration and for side by side or top/bottom ducts.

Heatex casing is a **built-in casing (not slide in casing)**, therefore it needs to be mounted and attached into an Air Handling Unit (AHU onwards). For more detailed information please refer to the “Installation and Maintenance Manual”.

#### 3.1. Casing Types

Heatex offers the following casing options.

##### 3.1.1. Standard Design

The standard E casing has the dimensions according to Table 2 and 3 (see Figure 5 for specific dimensions). The casing is open from the 4 sides as seen in Figure 4.

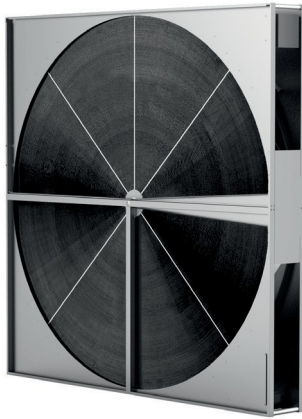

Figure 4. E standard casing.

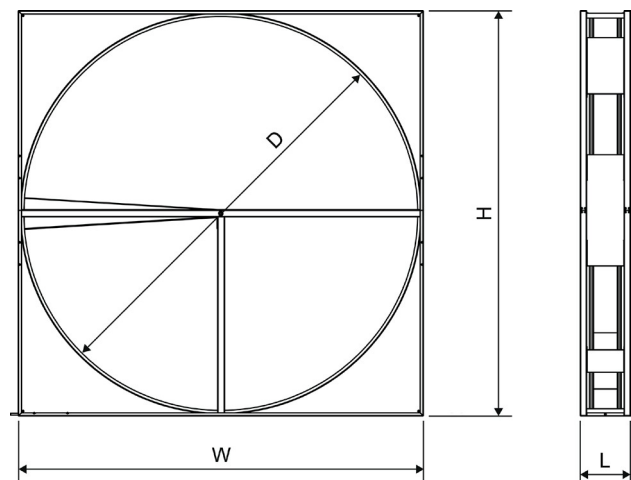

Figure 5. E casing measurements.

Wheel diameter D <sup>1</sup> (mm)	H x W <sup>2</sup> Variable drive (mm x mm)	H x W <sup>2,3</sup> Constant drive (mm x mm)	Casing depth L (mm)	Casing weight <sup>4</sup> (kg)	Casing weight <sup>5</sup> (kg)	Amount of spokes <sup>6</sup>	Type of beam
500	550 x 550	600 x 600	276	18.6	21.0	2	Middle beam
700	750 x 750	800 x 800	276	23.3	26.4	2	
900	950 x 950	1000 x 1000	276	28.6	32.3	8	
1100	1150 x 1150	1200 x 1200	276	34.5	42.5	8	
1101	1151 x 1151	1151 x 1151	316	34.7	42.7	8	Extra supportive beam (T Beam)
1300	1350 x 1350	1350 x 1350	316	48.1	48.1	8	
1500	1550 x 1550	1550 x 1550	316	55.1	55.1	8	
1750	1800 x 1800	1800 x 1800	316	66.3	66.3	16	
2000	2050 x 2050	2050 x 2050	316	76.5	76.5	16	
2250	2300 x 2300	2300 x 2300	316	89.1	89.1	16	
2500	2550 x 2550	2550 x 2550	316	101.1	101.1	16	

Table 2. E Casing dimensions and weight, metric units.

Wheel diameter D' (inches)	H x W <sup>2</sup> Variable drive (inches)	H x W <sup>2,3</sup> Constant drive (inches)	Casing depth L (inches)	Casing weight <sup>4</sup> (lb)	Casing weight <sup>5</sup> (lb)	Amount of spokes <sup>6</sup>	Type of beam
19.69"	21.65 x 21.65	23.62 x 23.62	10.87	41	46	2	Middle beam
27.56"	29.53 x 29.53	31.49 x 31.49	10.87	51	58	2	
35.43"	37.40 x 37.40	39.37 x 39.37	10.87	28.6	71	8	
43.31"	45.28 x 45.28	47.24 x 47.24	10.87	76	94	8	
43.35"	45.31 x 45.31	45.28 x 45.28	12.44	77	95	8	Extra supportive beam (T Beam)
51.18"	53.15 x 53.15	53.15 x 53.15	12.44	106	106	8	
59.06"	61.02 x 61.02	61.02 x 61.02	12.44	121	121	8	
68.90"	70.87 x 70.87	70.87 x 70.87	12.44	146	146	16	
78.74"	80.71 x 80.71	80.71 x 80.71	12.44	169	169	16	
88.58"	90.55 x 90.55	90.55 x 90.55	12.44	196	196	16	
98.43"	100.39 x 100.39	100.39 x 100.39	12.44	223	223	16	

Table 3. E Casing dimensions and weight, imperial units.



NOTE! The casing needs to be attached to the AHU ducts. Please refer to "Installation and Maintenance Manual" for more information.

<sup>1</sup> Wheel diameter can be selected in steps of 1 mm.

<sup>2</sup> Height and width can be adapted after customer requirements.

<sup>3</sup> Note that for constant motors and diameters below 1100 mm (43.31") the casing dimensions have to be adapted as shown in Table 2 or 3.

<sup>4</sup> Casing weight variable drive

<sup>5</sup> Casing weight constant drive

<sup>6</sup> The amount of spokes described is for vertical applications.

### 3.1.2. Covered Casing (Optional)

It is possible to order the casing covered also on the 4 sides. The design and dimensions are the same as the standard model.

### 3.1.3. Other Options

#### 3.1.3.1. Non-Standard Casing Dimensions

Casing for model E can be designed with non-standard dimensions in cases where e.g. width and height should not be the same. As long as the space between rotor and casing is enough and e.g. motor can fit. Maximum width and height of casing is 2850mm.

#### 3.1.3.2. Inspection Hatches

Inspection hatches are apertures for easy maintenance of the different rotor parts. These are needed especially if the casing chosen is covered, as there is no access to the different components from the sides.

Figure 6 shows a sketch of one inspection hatch.

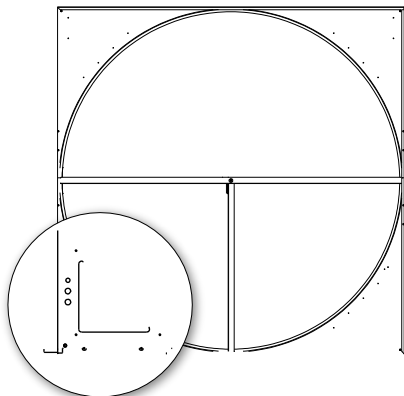

Figure 6. Sketch of inspection hatches.

#### 3.1.3.3. Hygienic certified Casing

With some minor adjustments the Heatex casing is fulfilling the requirements set by VDI 6022 page1, VDI 3803 page 1, SWKI 104-01, ÖNORM H6021 and EN 13779. The adjustments are:

- Inspection hatches at all corners.
- Special belt that is hygienic certified according to ISO 846.

## 3.2. Casing Material

### 3.2.1. Galvanized Steel

Heatex standard casing material is galvanized steel. This gives a good corrosion resistance and is therefore widely used in ventilation systems.

### 3.2.2. Painted Framework

Heatex offers, as an option, the standard casing with powder coated finish for increased corrosion resistance.

## 3.3. Drive Units

Heatex offer two main types of drive units; variable speed with controller and constant motor. Independent of drive unit type the rotor performance is based on standard rotation speeds, see table 4 below.

Matrix material	Standard rotational speed (rpm)
Condensation & Enthalpy	12
Adsorption (Silica gel)	17
Adsorption (Molecular sieve)	25

Table 4. Standard rotational speed.

### 3.3.1. Variable Speed with Controller

The standard drive unit provided by Heatex is a variable drive with controller. The customer is able to vary and set the speed depending on the needs. The motor included in the standard drive unit is a stepping motor, with an input signal of 0-10 volt. The option with Modbus is also available.

Figure 7 compares the input power of an AC motor with gear and a stepping motor (both with controller) depending on the rotary speed. The behavior of the stepping motor allows the customer to regulate the rotor speed without expecting higher power consumptions. At normal conditions (12 rpm) the step motor consumes around 20% less power.

The motor size depends on the wheel diameter. In table 5 the different motor options in combination with matrix material and diameter are presented.

Key parameters for control and motor are shown in table 6.



### Input Power Stepping motor vs. AC motor with gear

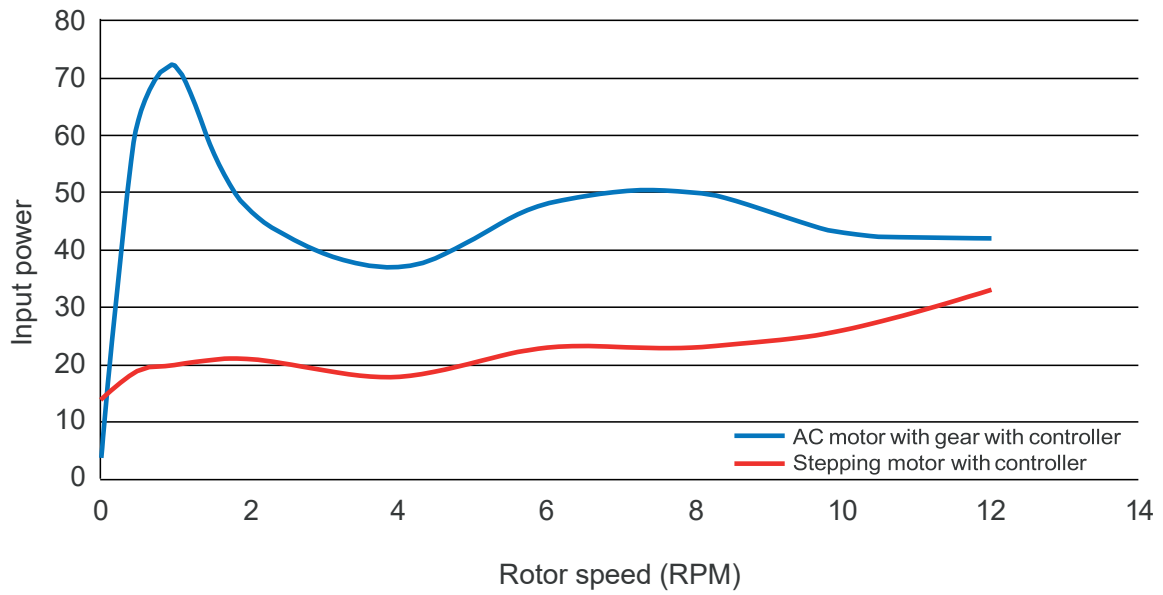

Figure 7. Input power vs rotor speed for a gearbox motor and a step motor.

Condensation & Enthalpy Wheels (Ø)	Condensation & Enthalpy Wheels Special Seal	Adsorption Wheels Silica Gel (Ø)	Adsorption Wheels Molecular Sieve (Ø)	Motor
500-1500 mm (19.69-59.06")	500-1500 mm (19.69-41.34")	500-1000 mm (19.69-39.37")	500-900 mm (19.69-35.43")	Varimax 25 & Varimax 25 NG
1501-2575 mm (59.09-101.38")	1501-2300 mm (41.38-90.55")	1001-1800 mm (39.41"-70.87")	901-1200 mm (35.47-47.24")	Varimax 50 & Varimax 50 NG
-	2301-2575 mm (90.59-101.38")	1801-2575 mm (70.91-101.38")	1201-2575 mm (47.28-101.38")	Varimax 100
500 - 1500 mm (19.69 - 59.06")	500 - 1500 mm (19.69 - 41.34")	500 - 1000 mm (19.69 - 39.37")	500 - 900 mm (19.69 - 35.43")	OJ 2Nm
1501 - 2575 mm (59.09 - 101.38")	1501 - 2300 mm (41.38 - 90.55")	1001 - 1800 mm (39.41 - 70.87")	901 - 1200 mm (35.47 - 47.24")	OJ 4Nm
-	2301 - 2575 mm (90.59 - 101.38")	1801 - 2575 mm (70.91 - 101.38")	1201 - 2575 mm (47.28 - 101.38")	OJ 8Nm

Table 5. Variable drive unit and rotor material combinations.

<sup>6</sup> Standard rotor speed is set to provide the best performance. Rotor speed can be lowered if needed. The effect of lowered rotor speed can be calculated in Heatex Select.

Motor	Max torque (Nm)	Supply power (V-Hz)	Input current max (A)	Protection form, control/motor
Varimax 25	2	1x230 - 50/60	0.9	Type 1/IP54
Varimax 50	4	1x230 - 50/60	1.9	Type 1/IP54
Varimax 100	10	1x230 - 50/60	2.2	Type 1/IP54
Varimax 25 NG	2	1x230 - 50/60	0.8	IP44/IP54
Varimax 50 NG	4	1x230 - 50/60	1.65	IP44/IP54
OJ 2Nm	2	1x230 - 50/60	0.6	IP54
OJ 4Nm	4	1x230 - 50/60	1.2	IP54
OJ 8Nm	8	1x230 - 50/60	2.4	IP54

Table 6. Variable drive unit data.



NOTE! The small casing sizes ( $\varnothing$  500-900 mm (19.69-35.43")) the controller for the variable speed motor will be delivered separately.



NOTE! Make sure that there is a 30s acceleration time while starting or stopping the rotation.

### 3.3.2. Constant drive

The constant drive provides the customer with a constant rotor speed. The speed is depending on matrix material, see table 4 with standard rotational speeds. All motors are induction motors, supplied with AC and are equipped with a thermo contact.

Condensation & Enthalpy Wheels (Ø)	Adsorption Wheels (Ø)	Nominal power	Supply (V/Hz)	Nominal speed (RPM)	Current <sup>1)</sup> (A)	Pole number	IP code	Mass with gear
500-800 mm (19.69-31.5")	500-600 mm (19.69-23.62")	25 W	1x220-240/50	1250	0.23-0,25	4	IP54	2.1 kg (4.63 lb)
			3x220-240/50	1250	0.18-0.28	4	IP54	2.1 kg (4.63 lb)
			3x380-420/50	1250	0.11-0.14	4	IP54	2.1 kg (4.63 lb)
801-1300 mm (31.54-51.18")	601-1300 mm (23.66-51.18")	40 W	1x220-240/50	1250	0.32-0.4	4	IP54	4.1 kg (9.04 lb)
			3x220-240/50	1250	0.3-0.39	4	IP54	4.1 kg (9.04 lb)
			3x380-420/50	1300	0.17-0.22	4	IP54	4.1 kg (9.04 lb)
1301-1500 mm (51.22-59.06")	-	90 W	3x220-240/50 <sup>2)</sup>	1400	0.66-0.7	4	IP55	3.9 kg (8.60 lb)
			3x380-420/50	1400	0.38-0.4	4	IP55	3.9 kg (8.60 lb)
1501-2100 mm (59.09-82.68")	-	180W	3x220-240/50 <sup>2)</sup>	1365	0.96-1.3	4	IP55	5.1 kg (11.24 lb)
			3x380-420/50	1365	0.55-0.75	4	IP55	5.1 kg (11.24 lb)
-	1301-1700 mm (51.22-59.06")	180W	3x220-240/50 <sup>2)</sup>	2780	0.8-0.95	2	IP55	4.1 kg (9.04 lb)
			3x380-420/50	2780	0.5-0.6	2	IP55	4.1 kg (9.04 lb)
2101-2575 mm (82.72-101.38")	1701-2575 mm (66.97-101.38")	370 W	3x220-240/50 <sup>2)</sup>	2830	1.63-1.7	2	IP55	7.6 kg (16.76 lb)
			3x380-420/50	2830	0.94-1.0	2	IP55	7.6 kg (16.76 lb)

Table 7. Motor options.

- 1) Current depends on motor brand.  
 2) Delivered in 3x400V mode, customer arrange switching to 3x230V.



NOTE! Due to the compactness of the new E casing and the size of the constant motors, the E model outer dimensions need to be modified if a constant motor is chosen from size 500 mm (19.69") to 1100 mm (43.31").



NOTE! The constant motor should be protected against over current by a separate and appropriate motor protection switch.

### 3.3.3. Belt

#### 3.3.3.1. Power Belt

Power belt is our toughest option due to high wear resistance. This belt is used without tensioning device and can be used at temperatures up to 110°C (230°F) and in humid climates. The belt is easily joined together without any tools or locks and is therefore easy to maintain. Power belt is offered for all rotor diameters.

Power belt is the standard option for rotors up to 1500 mm (59.06") in diameter when variable speed motor and special seals are chosen.



Figure 8. Power belt.

#### 3.3.3.2. Round Belt

The belt is 10 mm (0.39") in diameter. The elastic round belt is easy to use since it requires no maintenance or tension device. The hollow endless belt is joined together by welding in Heatex production. If the belt needs to be rejoined, this can be done by using a special pin that is delivered together with the casing. The alternative is to change the belt to a power belt.



Figure 9. Round belt.

### 3.3.4. Purge Sector

Due to the wheel rotation, some air gets trapped inside the matrix during the rotation from one air duct to the other. The air amount trapped in the wheel is transferred and mixed with the next air flow. If the air transferred is exhaust air into the supply air, the result is

the contamination of the supply air by a small amount of the exhaust air. This effect is called carry over or Exhaust Air Transfer Ratio (EATR onwards) and is expressed in percentage (%) of the total air flow.

The purge sector is optimized to reduce the carryover or EATR. It will stop the inlet of exhaust air in the small area right before airflows switch, thus avoiding exhaust air to get trapped into the matrix. A small amount of the supply air is used to blow out the minor amount of exhaust air that might have been trapped to ensure a fresh and clean supply air.

Figure 10 and 11 shows a scheme of the purge sector's main function.

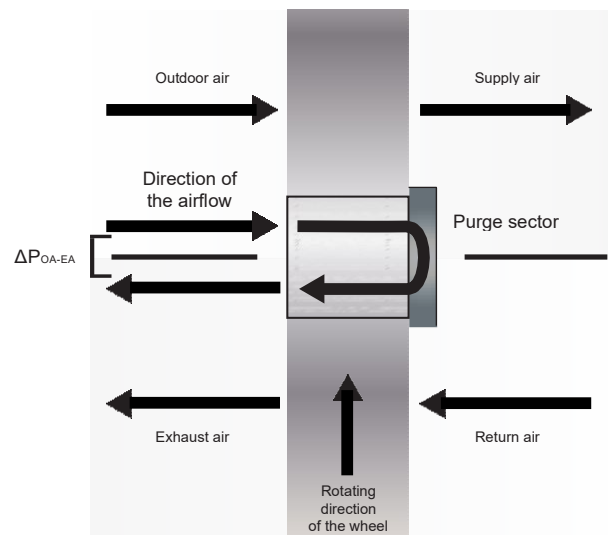

Figure 10. Description of purge sector's function.

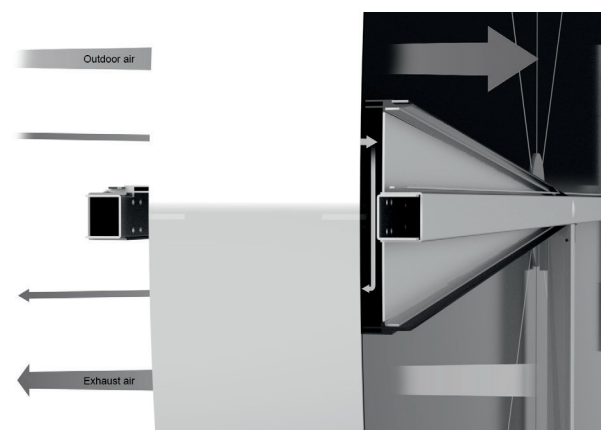

Figure 11. Sketch of the purge sector angle.

Depending on the airflow distribution, there are 4 possible purge sector positions. The angle depends on the wheel rotation speed.



**NOTE!** Once the position of the purge sector is selected there is no possibility to readjust to another position.



NOTE! The purge sector needs a pressure difference ( $\Delta P_{\text{OA-EA}}$ ) between 200 Pa (0.8" WC) and 500 Pa (2" WC) to work properly. Please remember that pressure differences exceeding 600 Pa (2.4" WC) are not allowed.

### 3.3.5. Seal Solution

#### 3.3.5.1. Leakage Introduction

There are two kinds of leakages, internal and external.

**External leakage** is considered to be the leakage from the unit to the surroundings. To reduce this leakage seals are placed on the diameter of the wheel and tight to the cover plate, so that the airflow will go through the wheel.

**Internal leakages** are considered to be the leakages within the unit. In this definition there is two different leakages; one is the carry over (or EATR) defined previously and is the consequence of the wheel rotation. The other one is called Outside Air Correction Factor (OACF onwards) which is the leakage taking place between the two air ducts due to pressure difference.

**Leakage between air ducts (OACF):** To ensure clean and fresh supply air, a higher pressure in the supply air against the exhaust air is needed. That pressure difference causes a gap in the seals between the air ducts and thus a leakage between the supply inlet and the exhaust outlet is generated. This effect reduces the amount of supply air going through the wheel and inside the building. To reduce this leakage, seals must be used in combination with a control of the pressure difference. Higher values of pressure difference lead to higher leakages.

The scheme below shows the distribution of internal leakages if the pressure on the outdoor air side is higher than on the exhaust air side.

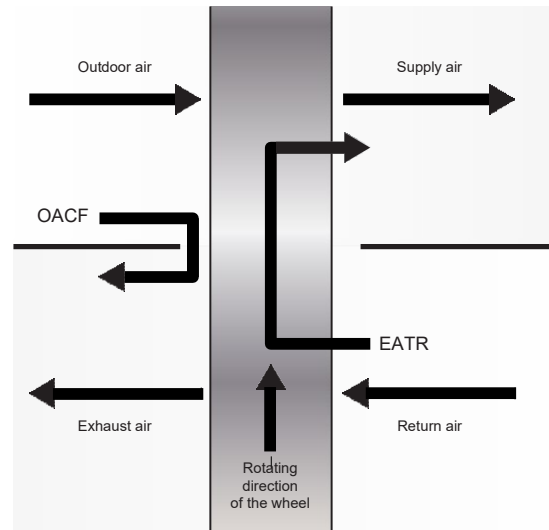

Figure 12. Description of internal leakages.

#### 3.3.5.2. Seals Placement

Seals have the purpose of sealing the RHE and reduce the leakage.

Figure 13 shows the outer seal, used to avoid external leakage.

Figure 14 shows the seals placed in the middle beam and across the purge sector. This seal have the purpose to avoid the internal leakage OACF.

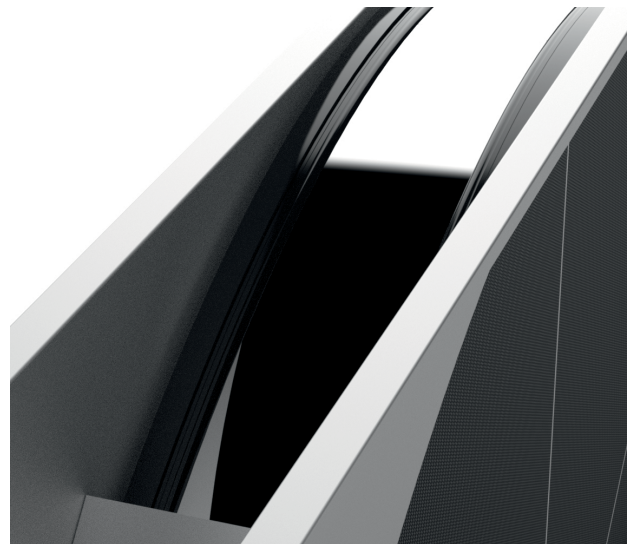

Figure 13. Outer seals to prevent external leakage.

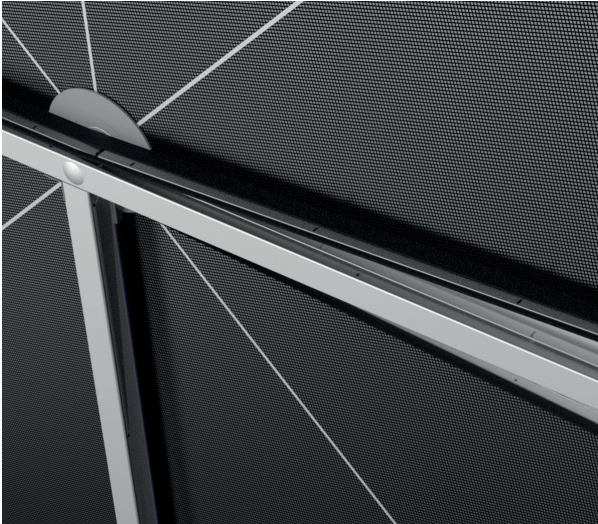

Figure 14. Middle beam seals to prevent internal leakage. (OACF).

### 3.3.5.3. Standard Seal

Heatex standard seal is the brush seal. The brush seal is made of a double layer of brush with an integrated plastic foil.



Figure 15. Standard brush seal.

### 3.3.5.4. Special Seal (Optional)

The brush fibers of the special seal are made of a special polymer that allows for better wear resistance against the wheel rotation and the rubber lips on both sides reduce the leakage to a minimum.

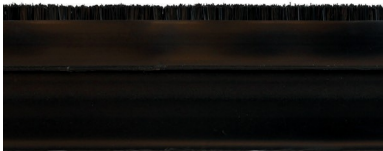
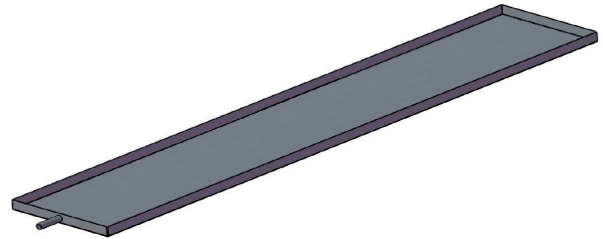

Figure 16. Optional special seal.

### 3.3.6. Condensing Tray (Optional)

With rising humidity the risk for condensation increases. The purpose of the stainless steel condensing tray is to gather the condensed water and easily transfer it to the outside of the AHU.



**NOTE!** The condensing tray must be completed with a water siphon installation to ensure that the water goes out of the system. The siphon must have a minimum pressure difference equal to the static pressure in the channel.

## 4. TECHNICAL INFORMATION

### 4.1. Application Limits

#### 4.1.1. Pressure Drop Limits

- Minimum allowed pressure drop is 50 Pa (0.2" WC).
- Maximum allowed pressure drop is 300 Pa (1.2" WC) if wheel diameter is below or equal to 1600 mm (62.99").
- Maximum allowed pressure drop is 250 Pa (1" WC) if wheel diameter is larger than 1600 mm (62.99").

The recommended pressure drop under normal conditions is between 100-200 Pa (0.4-0.8" WC).



**NOTE!** Lower pressure drops than the minimum stated will result in unreliable heat transfer, while higher pressure drops than the maximum specified can result in mechanical failure.



**NOTE!** The maximum allowed pressure drop must not be exceeded under any conditions, since this can lead to mechanical failure.



### 4.1.2. Differential Pressure Limits

The maximum pressure difference allowed is 600 Pa (2.4" WC).

The maximum recommended pressure difference (between supply air inlet and exhaust air outlet) based on the life-time expectations of the bearings is 500 Pa (2" WC) but should be kept to a minimum since otherwise wear of bearings and brush seals will be high and the leakage rate will also increase with pressure difference. A high-pressure difference may also cause the casing to deflect. Please be aware of that for the purge sector to work the pressure difference should be higher than about 200 Pa (0.8" WC) and lower than about 500 Pa (2" WC).



NOTE! The highest pressure should be on the supply side to guarantee a clean and fresh air inside the building; otherwise exhaust air can leak into the supply air.



NOTE! The maximum allowed pressure difference should not be exceeded under any conditions.

### 4.1.3. Temperature Limits

The overall air temperature limits for the whole unit are -40°C (-40°F) to +65°C (149°F).

Each component has different temperature limits, for specific details, see table below.

Component	Min Temp.	Max Temp.
Bearings	-40°C (-40°F)	110°C (230°F)
Round belt	-30°C (-22°F)	66°C (150°F)
Power belt	-40°C (-40°F)	110°C (230°F)
Constant motor	-10°C (14°F)	40°C (104°F)
Varimax step motor and control	-30°C (-22°F)	45°C (113°F)
OJ step motor and control with modbus	-40°C (-40°F)	40°C (104°F)
Standard seals	-25°C (13°F)	90°C (190°F)
Special seals	-25°C (13°F)	90°C (190°F)

Table 7. Temperature limits for different components.

The temperature inside the casing can be considered as the average temperature between the supply and the exhaust inlet temperatures.



NOTE! The AHU manufacturer should take into consideration the positioning of the motor so that the temperature limits are kept.

## 4.2. Freezing

First of all, freezing in a RHE only occur if condensate is present. Secondly, severe freezing is not common in a RHE due to the rotation of the wheel. Frost that appear in the cold air stream normally melts in the warm air stream. Freezing can however occur in certain circumstances. The freezing process depends on the level of condensate and the air stream temperatures. Frost becomes a problem when it builds up faster than it melts. This process normally takes many hours. It is important to be observant if the pressure drop increases during long periods of cold inlet temperatures. Frost building up in the matrix can cause high differential pressures leading to severe damage on the wheel.

The Heatex Select software includes a warning indicating if the conditions chosen could lead to freezing problems. The warning is based on field experience and on the rule of thumb that risk of freezing is higher if the average temperature of the two inlet air streams is below zero.

$$T_{average} = \frac{T_{in,warm} * m_{warm} + T_{in,cold} * m_{cold}}{m_{warm} + m_{cold}}$$

There are several methods to prevent frost accumulation:

- Preheating of the outdoor air in e.g. a heating coil. With a higher temperature, condensation can be avoided, and the average temperature is increased (above 0°C) so that the risk of freezing decreases.
- By lowering the rotor speed the heat transfer efficiency will decrease. This is thus another way to avoid condensation and possible freezing.
- If bypassing the cold air stream or parts of it, it is possible for the warm side to melt any frost build up. Once the frost is gone, monitored by e.g. pressure drop measurement, the cold side bypass can be closed, and normal operation restarted.

### **4.3. Condensation**

Condensed water can block the channels leading to unexpected higher pressure drops. The following can be done to avoid condensation in the RHE:

- Reduce the humidity in the warm airflow (dehumidification) before entering the wheel.
- Select a larger well height which will lead to lower performance hence avoiding or reducing condensation.

### **4.4. Wheel Protection**

The AHU manufacturer should at all times make sure that the wheel is kept clean and free from dust and other particles during operation and start-up.

#### **4.4.1. Cleaning**

Please refer to the “Installation and Maintenance Manual” for more information regarding cleaning of the product.

### **4.5. Heatex Select**

Heatex Select is Heatex’s own calculation software that allows the customer to calculate the performance of the chosen unit. The calculation tool is available as online and offline platforms as well as a separate .dll to implement in the customers own software. See [heatex.com](http://heatex.com) for more information



### 4.6. Fan Positioning

Recommended fan configuration is to have both fans on the exit sides of the heat exchanger and to always make sure that pressure is higher on the supply side than on the exhaust side. In this way leakage will be from the fresh air side to the exhaust side, not affecting the indoor air quality.

However, the table below explains the different fan configurations and its advantages. Where,

$P_{11}$  = Static pressure, exhaust air inlet

$P_{12}$  = Static pressure, exhaust air outlet

$P_{21}$  = Static pressure, supply air inlet

$P_{22}$  = Static pressure, supply air outlet

Fan location	Description
	<p>This combination has two pulling fans for both the supply and the exhaust airflows. If correctly adjusted, a proper pressure difference between the supply and the exhaust air can be kept and therefore achieve relatively low EATR and OACF values.</p>
	<p>In this particular arrangement, the supply air is pulled and the exhaust air is pushed, leading to a higher pressure on the exhaust air duct, causing a high EATR and low OACF. If contamination of exhaust air is not an issue, this might be a good combination since it keeps the OACF low.</p>
	<p>This combination has two pushing fans for the supply and the exhaust airflows. If correctly adjusted, a proper pressure difference between the supply and the exhaust air can be kept and therefore achieve relatively low EATR and OACF values.</p>
	<p>This is the best combination to avoid exhaust air leaking into the supply air. The exhaust air is pulled while the supply air is pushed through the air duct. This combination will lead to a high-pressure difference between the supply and the exhaust airflow, leading to very low EATR but high OACF.</p>

Table 8. Fan configurations in the AHU.

## 4.7. Rotor Positioning

Heatex is able to offer two rotor arrangements.

### Vertical

The whole unit is standing up with a 90° angle to the floor.

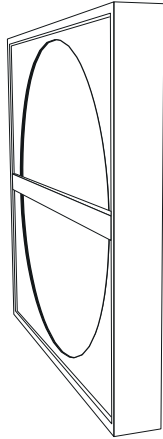

Figure 17. Vertical rotor position.

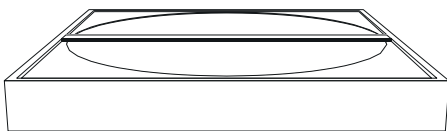

Figure 18. Horizontal rotor position

### Horizontal

The whole unit lays down parallel to the floor.



**NOTE!** The position is chosen during selection and cannot be changed once the wheel is manufactured.

## 4.8. Air flow arrangement in the AHU

Heatex is able to offer two air flow arrangements for the AHU.

### Side to side

The duct separation (beam) is vertical from top to bottom of the heat exchanger. The air flows on the right and left side of the beam.

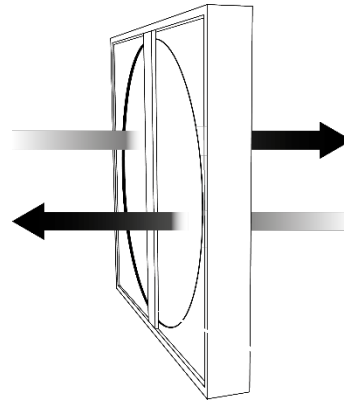

Figure 19. Side to side air flow arrangement.

### Top to bottom

The duct separation (beam) is horizontal from side to side of the heat exchanger. The air flows on top and bottom side of the beam

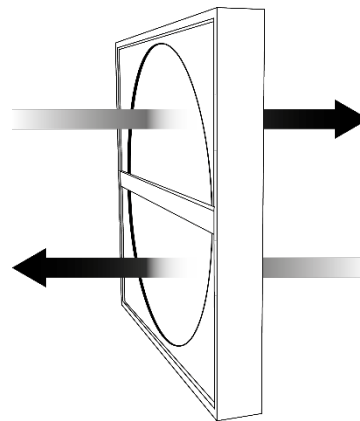

Figure 20. Top to bottom air flow arrangement.



**NOTE!** The air flow arrangement is chosen during selection and cannot be changed once the wheel is manufactured.

## 5. SUPPORT

### 5.1. Installation and Maintenance Manual

For more information regarding the installation and maintenance of the product please refer to the “Installation and Maintenance Manual Model E”.

### 5.2. Name Description

Below there is a guide to choose the right product code.

Name	E	A	0700x0700	-	0650	V	-	020	-	2	B	D	OO	-	8	A	R	0	-	A
Position	1	2	3		4	5		6		7	8	9	10		11	12	13	14		15

Position	Characteristic	Code
1	Model	E = Rotating heat exchanger in casing
2	Matrix material	A = Aluminum E = Epoxy K = Hybrid with silica gel L = Hybrid with molecular sieve D = Silica gel M = Molecular sieve
3	Casing dimensions	Width x Height (WxH) Maximum 2850x2850mm
4	Rotor diameter	From 500 mm (19.69”) up to 2575 mm (101.38”)
5	Heat exchanger orientation	H = Horizontal V = Vertical
6	Well height	To choose: 014 – 016 – 018 – 020 – 022 – 025
7	Hub	2 = Ball bearing with shaft 7 = Ball bearing with shaft, corrosion resistant
8	Casing	B = All covered casing D = Simple casing E = All covered casing with airflow sidewise G = Simple casing with airflow sidewise
9	Purge sector	0 = No purge sector A = Front side on the right resp. front side upwards B = Front side on the left resp. front side downwards C = Back side on the right resp. back side upwards D = Back side on the left resp. back side downwards
10	Option	OO = Standard product DB = Painted framework RA = Inspection hatches RB = Condensate tray motor side RC = Condensate tray non-motor side RD = Cable glands CI = According to special drawing/instruction  <b>Note:</b> Combinations of options are described in a separate document.
11	Drive equipment	0 = No drive 6 = Constant drive 3 Phases, 380V 7 = Constant drive 3 Phases, 230V 8 = Varimax step drive A = OJ step drive with Modbus B = NG Varimax step drive with Modbus

Position	Characteristic	Code
11	Drive equipment for North American market	0 = No drive E = Constant drive 115V/1Ph/60Hz F = Constant drive 208V/3Ph/60Hz G = Constant drive 230V/3Ph/60Hz H = Constant drive 460V/3Ph/60Hz I = Constant drive 575V/3Ph/60Hz 8 = Advanced step drive & control J =E+ Variable frequency drive K =F+ Variable frequency drive L =G+ Variable frequency drive M =H+ Variable frequency drive N =I + Variable frequency drive
12	Drive equipment position	0 = No motor A = Floor, left side B = Floor, right side C = Roof, right side D = Roof, left side
13	Drive belt	0 = No drive R = Round drive belt P = Powerbelt
14	Rotation Detector	0 = No detector I = With detector
15	Seals	A = Standard B = Special seals

Table 9. Name descriptions.

### 5.3. Design Options

#### 5.3.1. Plane of Intersection & Purge Sector Placement

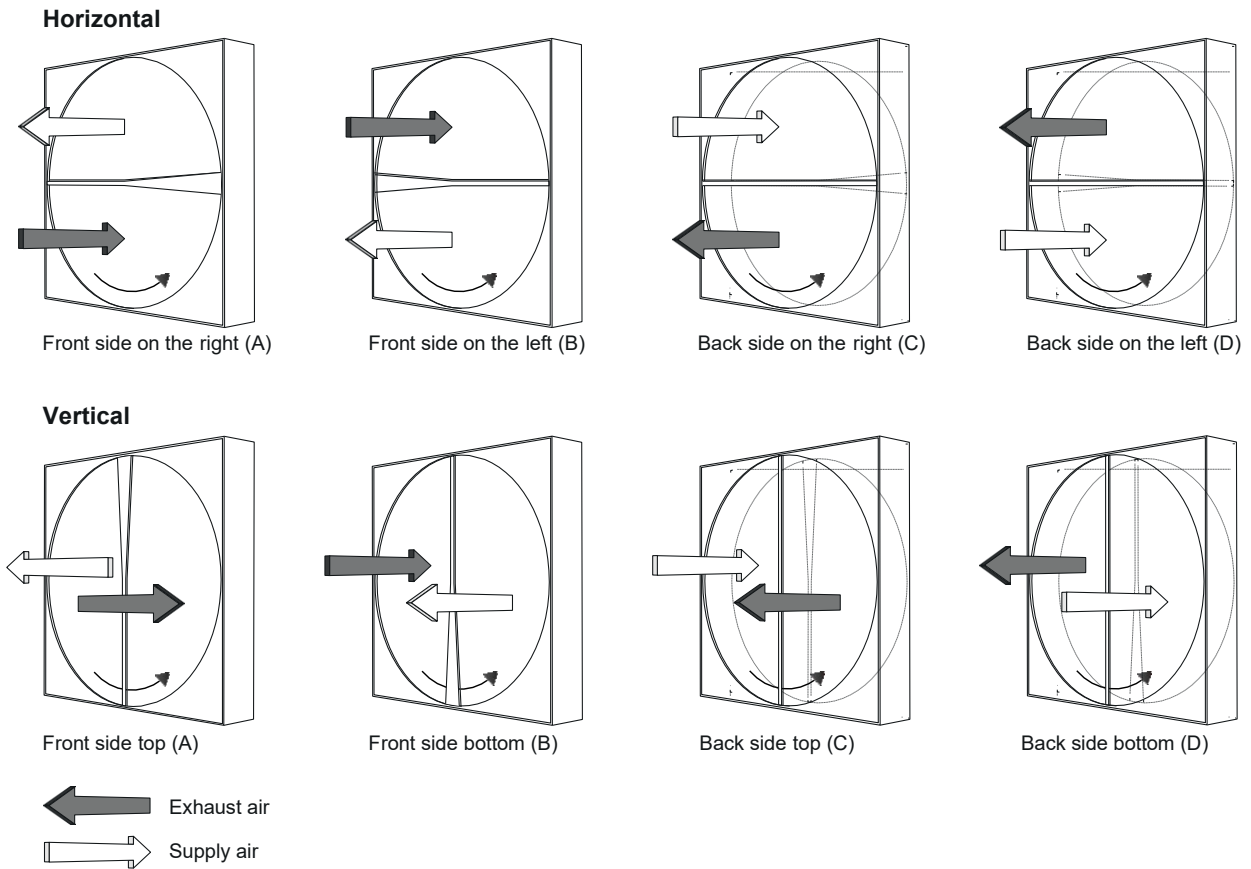

Figure 21. Purge sector placement options.

#### 5.3.2. Drive Location

Drive installation on casing floor is Heatex standard option. Installation in the upper/ceiling position is treated via special order.

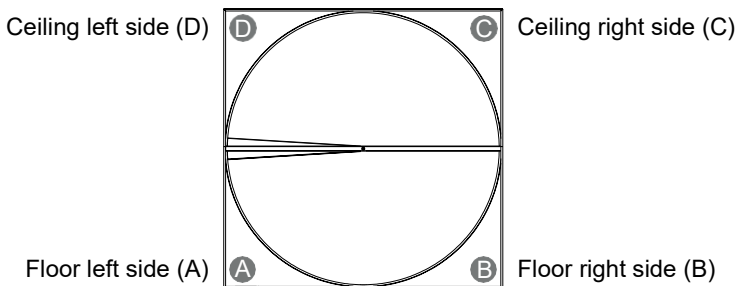

Figure 22. Drive location options.

## 5.4. Definition Description

Symbol	Formula	Name	Description
$t$		Temperature	It refers to the temperature of the airflows.
$x$		Absolute humidity	It refers to the absolute humidity/moisture in the airflows.
$h$		Total enthalpy	It refers to the total energy per kilogram stored in the airflows.
$\dots w$		Wet bulb	Wet bulb temperature is a way to define the absolute humidity or moisture content in the air. Considering the actual moisture content of the air, the wet bulb temperature is the temperature where the relative humidity would be 100% if the absolute moisture content remained unchanged.
$\dots d$		Dry bulb	Dry bulb temperature is the temperature that thermometers read. It does not refer to the temperature with 0% relative humidity.
$\eta_t$	$\eta_t = \frac{t_{22} - t_{21}}{t_{11} - t_{21}}$	Temperature efficiency	Is defined as the temperature gain or lose divided by the maximum value of temperature difference. In other words, the difference between the outlet and inlet temperature divided by the two inlet temperatures
$\eta_x$	$\eta_x = \frac{x_{22} - x_{21}}{x_{11} - x_{21}}$	Humidity efficiency	Is defined as the moisture gain or lose divided by the maximum value of moisture difference. In other words, the difference between the outlet and inlet moisture divided by the two absolute inlet moisture
$\eta_h$	$\eta_h = \frac{h_{22} - h_{21}}{h_{11} - h_{21}}$	Total (enthalpy) efficiency	Is defined as the energy gain or lose divided by the maximum value of energy to transfer. In other words, the difference between the outlet and inlet enthalpies divided by the inlet enthalpies.
$\epsilon_t$	$\epsilon_t = \frac{\dot{m} t_{22} - t_{21}}{\dot{m}_{min} t_{11} - t_{21}}$	Sensible effectiveness	Sensible effectiveness takes into account the difference in mass balance. It is calculated by multiplying the temperature efficiency times the specified mass airflow divided by the minimum airflow.
$\epsilon_x$	$\epsilon_x = \frac{\dot{m} x_{22} - x_{21}}{\dot{m}_{min} x_{11} - x_{21}}$	Latent effectiveness	Latent effectiveness takes into account the difference in mass balance. It is calculated by multiplying the humidity efficiency times the specified mass airflow divided by the minimum airflow.
$\epsilon_h$	$\epsilon_h = \frac{\dot{m} h_{22} - h_{21}}{\dot{m}_{min} h_{11} - h_{21}}$	Total effectiveness	Total effectiveness takes into account the difference in mass balance. It is calculated by multiplying the total efficiency times the specified mass airflow divided by the minimum airflow.

Table 10. Definition description.

## 5.5. Heatex Support

For information or questions regarding this product visit [heatex.com](http://heatex.com) or contact customer support.