

# PRODUCT CATALOG

**THE PROMISE  
THE PROOF  
HEATEX**

AIR-TO-AIR HEAT EXCHANGERS

**HEATEX**

# OUR MISSION

---

*"Heatex' mission is to make the world safer, healthier, and more productive through the development and supply of energy-saving products and solutions.*

- We make good indoor air quality a net saving rather than a cost*
- We protect sensitive equipment critical in modern society*
- We help reduce overall energy consumption, including fossil fuels and protect our environment for future generations."*

*/Pierre Nyström CEO*





## **HEATEX - THE COMPANY**

Heatex is a leading cleantech company that optimizes and develops energy-saving thermodynamic products and solutions that save cost and contribute to a sustainable future.

Established in 1987, guided by our core values Excellence, Honesty, and Simplicity, Heatex has today become one of the top manufacturers of air-to-air heat exchangers in the world and a trusted partner to both global corporates and local champions.

Heatex is part of Madison Industries, one of the world's largest and most successful privately held companies. Madison builds entrepreneurially driven, branded market leaders committed to making the world safer, healthier, and more productive by creating innovative solutions that deliver outstanding customer value.

## **OUR PRODUCTS & SOLUTIONS**

Heatex specializes in air-to-air heat exchangers whose purpose is to: (a) make good indoor air quality a net saving rather than a cost; and (b) protect sensitive equipment from excessive temperatures by maximizing the heat transfer between air flows. By maximizing the heat transfer between air flows, we recover otherwise wasted heat (energy), thereby financially reducing costs and environmentally cutting carbon emissions. We specialize in custom solutions that provide optimal energy recovery and fast return on investment no matter the application.

## **AND THEIR APPLICATIONS**

Heatex heat exchangers are used in a variety of buildings, industries, and applications. The application determines which heat exchangers and/or systems provide the best solution.

AHU manufacturers use Heatex heat exchangers as key components in HVAC systems to transfer heat or control humidity between supply and exhaust airstreams (see Indoor Air Quality). Air-to-air heat exchangers also enable reliable and energy-efficient cooling of heat-emitting processes such as sensitive electronics and generators (see Thermal Management).

# INDOOR AIR QUALITY

## COMMERCIAL & RESIDENTIAL VENTILATION

HVAC systems play a crucial role to maintain healthy and comfortable indoor air quality (IAQ) in almost all buildings.

Research shows good IAQ substantially helps improve productivity in business, raise grades in schools, and minimize hazardous pathogens in the air. Most often, good IAQ is best realized through fresh air exchange as opposed to recirculation.

The challenge for real estate owners and landlords is providing a healthy and comfortable IAQ with as little energy input (=cost) as possible.

With Heatex air-to-air heat exchangers, as much as 90% of the energy cost for tempering supply air can be saved and the return on investment is in many cases less than twelve (12) months.



## INDUSTRIAL VENTILATION

Many industrial processes generate large amounts of hot and humid air.

These processes have a great potential for energy/heat recovery and air pollution control, which can significantly reduce energy consumption (= cost) and environmental impact.

When large amounts of waste heat are generated, air-to-air heat exchangers are employed to recover the otherwise wasted heat and preheat the incoming process air—resulting in significantly reduced operating costs.

Heatex air-to-air heat exchangers are ideal for numerous industrial applications, including dehumidification and water removal, process heat or refrigeration recovery, and humidity transfer.

# THERMAL MANAGEMENT

## DATA CENTER COOLING

Thermal Management is a key factor in the cost and operation of data centers. Heatex heat exchangers, especially when coupled with evaporative cooling technology, provide an efficient, low cost and environmentally friendly alternative to remove excess heat from data center air.



## WIND TURBINE COOLING

To ensure the life expectancy of the components inside the nacelle the heat generated by the process of energy conversion and solar radiation needs to dissipate. Heatex develops complete and customized air-to-air cooling systems for generator, nacelle and converter/ transformer cooling. All systems are suitable for both onshore and offshore applications due to their corrosion resistant closed loop design.

## ELECTRONIC COOLING

Electronic equipment constantly gets more sophisticated and sensitive. To function reliably, it needs to be protected from water, dust, and excess heat.

Heatex develops complete closed-loop cooling systems based on air-to-air heat exchangers for a variety of enclosures and cabinets used in telecom, digital media, and solar applications. All systems are highly flexible and customizable.



## INDOOR AGRICULTURE

Greenhouse cultivation is an energy-intensive sector, energy consumption for indoor grow operations are many times higher than of typical office buildings.

Almost 50% of the energy use stems from ventilation, cooling, and dehumidification. Air handling units equipped with an Heatex air-to-air heat exchanger can save 60% -70% of the energy required to control climate typical greenhouse grow facilities.

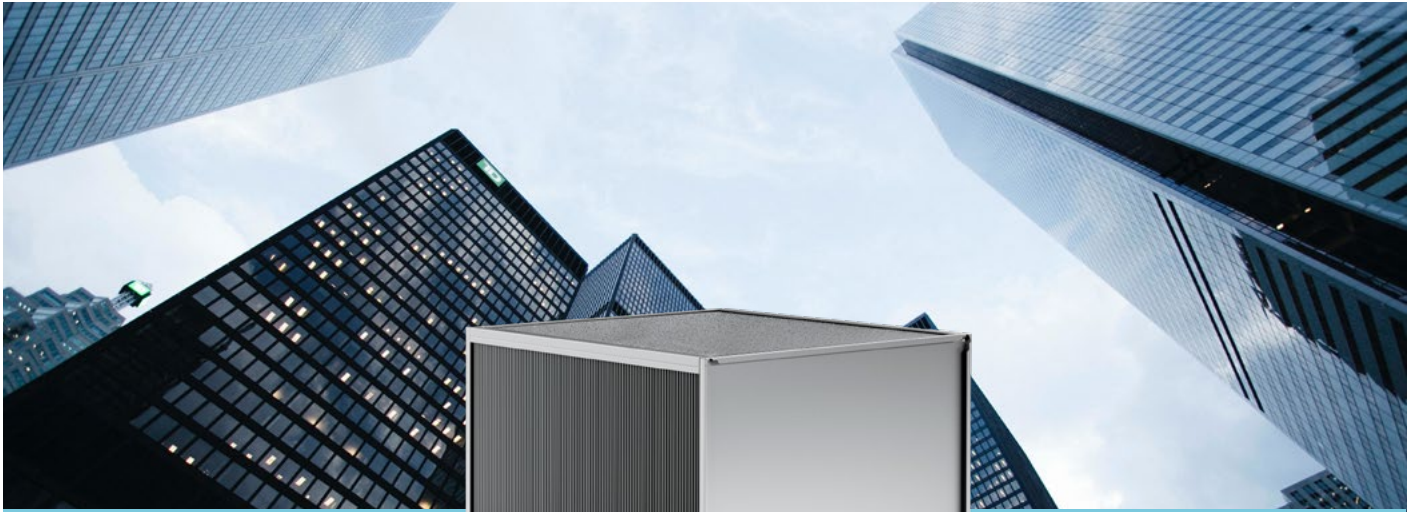

## PLATE HEAT EXCHANGERS

Heatex offers a broad range of plate heat exchangers. All units are produced according to our standardized processes with our proprietary production equipment at our global facilities, ensuring uniform product quality and favorable lead times worldwide.

### ADVANTAGES

---

- **HIGH EFFICIENCY**

With Heatex heat exchangers, up to 90% of the heat in the exhaust air is transferred to the supply air.

- **LONGEVITY**

No moving parts and strong aluminium plates in high standard alloy give the products a long lifetime and minimal need of service.

- **EASY MAINTENANCE**

The design allows for rapid and thorough cleaning and servicing.

- **FULLY CUSTOMISED**

All of our products are carefully designed to meet the demands for each specific application application and minimize the investment relative to the energy recovery need.

- **WIDE RANGE OF OPTIONS**

We offer an extensive range of design options regarding materials, sizes and components to suit various application and performance requirements.

- **CLOSED LOOP AIR STREAMS**

Depending on the application requirements, Heatex plates enable closed-loop airstreams to protect both people and equipment.

CROSS FLOW HEAT EXCHANGERS

# COMPARE MODELS



Every model has a clear advantage depending on the application. To determine which model suits your application, please use our comparison table below.

MODEL	H2	H	P	Z
<b>Description</b>	Oustanding efficiency for commercial ventilation and high performance cooling.	Particular low pressure drop for basic ventilation and cooling applications.	Extra differential pressure resilience for industrial ventilation applications.	Exceptional durability and corrosion resistance for very tough applications.
<b>Efficiency</b>	Superior	High	High	High
<b>Airflow capacity</b>	Standard	High	High	Standard
<b>Plate material</b>	Aluminum/ epoxy	Aluminum/ epoxy	Aluminum/ epoxy	Stainless steel
<b>Size</b>	19.69" - 118.1"	7.87" - 118.1"	7.87" - 118.1"	23.62" - 47.24"
<b>Max. diff. pressure</b>	12.04" WC	7.23" WC	12.26" WC	16.06" WC

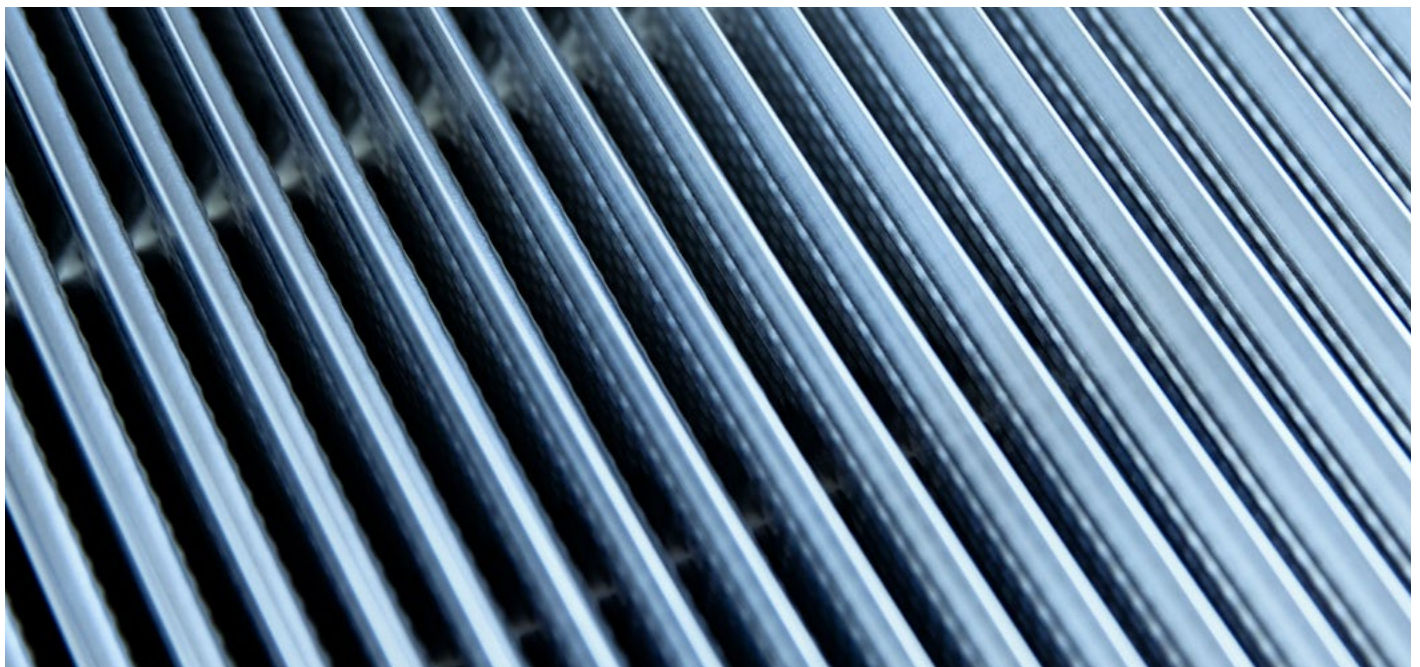

## CROSS FLOW HEAT EXCHANGER

# MODEL H2

Superior Efficiency

Model H2 is our most efficient cross flow plate heat exchanger. It combines low-weight with high differential pressure resistance and is able to reach typical dry temperature efficiencies above 80%.

The efficiency is improved by its slim profiles and our superior efficiency plate design, creating high turbulence even at lower velocities while keeping pressure drop low.

Model H2's performance is certified according to AHRI.

All Heatex cross flow plate heat exchangers meet several hygiene requirements.



## TECHNICAL SPECIFICATIONS & OPTIONS

### PLATE MATERIAL:

- Aluminum
- Epoxy (for corrosion protection)

### CORNER PROFILE:

- 90° Aluminium profile
- 45° Aluminium profile

### ENDPLATE:

- Aluzinc
- Aluminum

### SEALING:

- Silicone free (max 190°F)
- Silicone (max 390°F)
- High temperature silicone (max 464°F)

### MIN. ALLOWED TEMPERATURE:

- -104°F

### MAX. LEAKAGE (IN %):

- 0.1% of nominal airflow with non-silicone at 1.60"
- 1% of nominal airflow for all models with silicone sealant

### ADDITIONAL OPTIONS:

- Product tightness test incl. report
- Painted framework (max 190°F)
- Closed plate cutting edges (max 190°F)
- ATEX testing
- Water tightness treatment
- Heatex damper

### MAX. ALLOWED DIFFERENTIAL PRESSURE:

- 7.23" WC - 12" WC, depending on plate spacing  
> 12" WC for plate spacing above 0.16" WC

For H2 1200/2400:

- 6" WC - 7.23" WC for plate spacing 0.08" - 0.12"  
> 12" WC for plate spacing above 0.16"



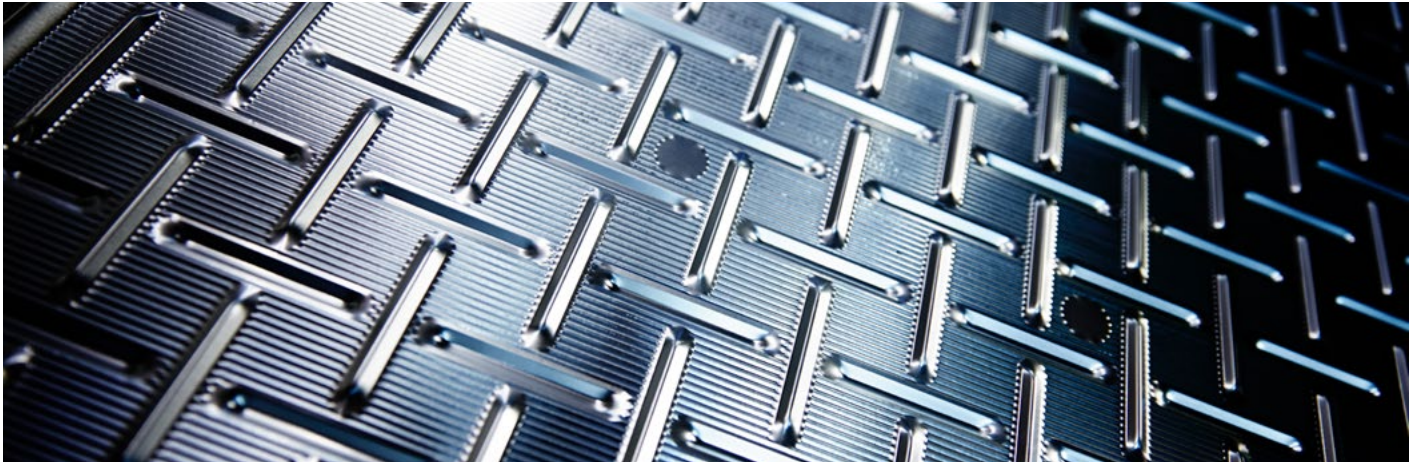

## MODEL H2 DIMENSIONS (INCH)

### COMBINED MODULES SIZE:

- 19.69" - 118.1"

### PLATE SIZE:

- 19.69"
- 23.62"
- 27.56"
- 29.53"
- 33.46"
- 39.37"
- 47.24"

**NOTE:** Customized A-dimensions can to some extent be created with special corner profile designs.

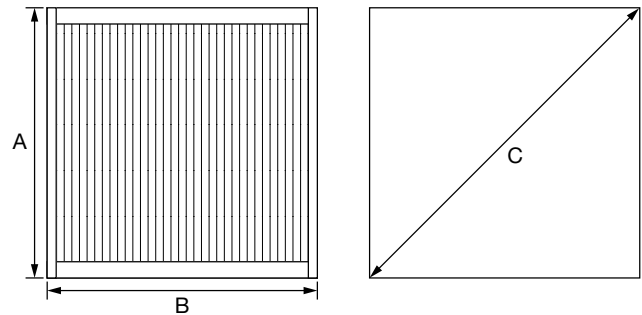

MODEL	A	B*	C45**	C90***	PLATE DISTANCE
500	19.69	9.84-39.37	27.09	27.83	0.075 / 0.079 / 0.098 / 0.12 / 0.16 / 0.20 / 0.24
600	23.62	9.84-47.24	32.64	33.43	0.075 / 0.079 / 0.087 / 0.098 / 0.12 / 0.16 / 0.20 / 0.24
700	27.56	11.81-47.24	38.19	38.98	0.079 / 0.098 / 0.12 / 0.16 / 0.20 / 0.24
750	29.53	11.81-47.24	40.98	41.77	0.079 / 0.083 / 0.098 / 0.12 / 0.16 / 0.20 / 0.24
850	33.45	11.81-47.24	46.54	47.32	0.079 / 0.083 / 0.087 / 0.098 / 0.12 / 0.16 / 0.20 / 0.24
1000	39.37	13.78-47.24	54.88	55.67	0.079 / 0.098 / 0.11 / 0.12 / 0.16 / 0.20 / 0.24
1200	47.24	13.78-47.24	On request	66.81	0.079 / 0.1 / 0.106 / 0.11 / 0.12 / 0.16 / 0.20 / 0.24 / 0.34 / 0.39
1400	55.12	13.78-47.24	77.17	77.95	0.079 / 0.098 / 0.12 / 0.16 / 0.20 / 0.24
1500	59.06	13.78-47.24	82.76	83.54	0.079 / 0.098 / 0.12 / 0.16 / 0.20 / 0.24
1700	66.93	13.78-47.24	93.86	94.64	0.079 / 0.098 / 0.12 / 0.16 / 0.20 / 0.24
2000	78.74	13.78-47.24	110.06	111.34	0.079 / 0.098 / 0.12 / 0.16 / 0.17 / 0.19 / 0.20 / 0.24
2250	88.58	13.78-47.24	124.5	125.28	0.079 / 0.098 / 0.12 / 0.16 / 0.20 / 0.24
2400	94.49	13.78-47.24	132.8	133.60	0.079 / 0.1 / 0.106 / 0.11 / 0.12 / 0.16 / 0.20 / 0.22 / 0.24 / 0.34 / 0.39
2550	100.39	13.78-47.24	141.2	141.97	0.079 / 0.098 / 0.12 / 0.16 / 0.20 / 0.22 / 0.24
3000	118.11	13.78-47.24	166.3	167.05	0.079 / 0.098 / 0.12 / 0.16 / 0.20 / 0.24

\* Maximum module width depends on plate orientation (vertical or horizontal), model and plate distance.

\*\* 45° corner profile.

\*\*\* 90° corner profile.

## CROSS FLOW HEAT EXCHANGER

# MODEL H

## Low Pressure Drop

Model H is Heatex' original cross flow plate heat exchanger with typical dry temperature efficiency up to 65% for a single pass and 85% for two-step arrangements.

Model H offers the widest set of options and configurations among our cross flow plate heat exchangers.

Model H's performance is certified according to AHRI.

All Heatex cross flow plate heat exchangers meet several hygiene requirements.



## TECHNICAL SPECIFICATIONS & OPTIONS

### PLATE MATERIAL:

- Aluminium
- Epoxy (for corrosion protection)

### CORNER PROFILE:

- 90° Aluminium
- 45° Aluminium
- Brush aluminum profile

### ENDPLATE:

- Aluzinc (for plate size > 23.62")
- Aluminium (for plate size < 11.81")

### SEALING:

- Silicone free (max 190°F)
- Silicone (max 390°F)
- High temperature silicone (max 464°F)

### MIN. ALLOWED TEMPERATURE:

- -104°F

### MAX. LEAKAGE:

- 0.1% of nominal air flow for sizes > 16.73" at 1.6" WC
- 1% of nominal airflow for sizes < 16.73" at 1" WC
- 1% of nominal airflow for all models with silicone sealant

### ADDITIONAL OPTIONS:

- Product tightness test incl. report
- Painted framework (max. 190°F)
- Closed plate cutting edges (max. 190°F)
- ATEX testing
- Heatex damper
- Water tightness treatment

### MAX. ALLOWED DIFFERENTIAL PRESSURE:

- 7.23" WC for most sizes
- 2.81" WC for size 7.87" and 11.81"

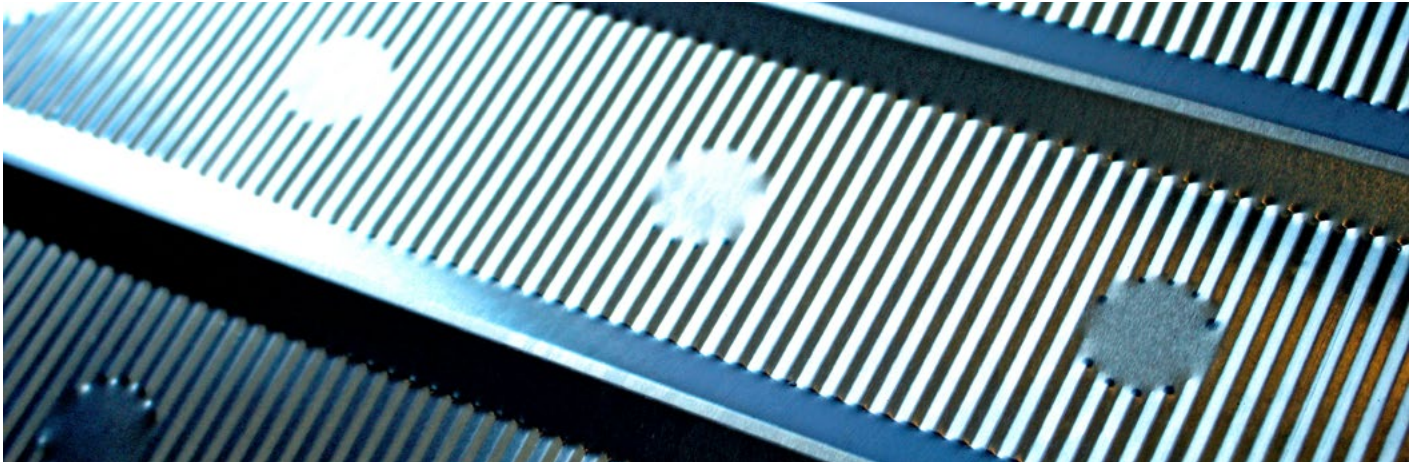

## MODEL H DIMENSIONS (INCH)

### COMBINED MODULES SIZE:

- 7.87" - 118.1"

### PLATE SIZE:

- 7.87"                      • 23.62"
- 9.84"                      • 29.53"
- 11.81"                     • 31.50"
- 16.34"                     • 33.47"
- 16.73"                     • 39.37"
- 19.29"

**NOTE:** Customized A-dimensions can to some extent be created with special corner profile designs.

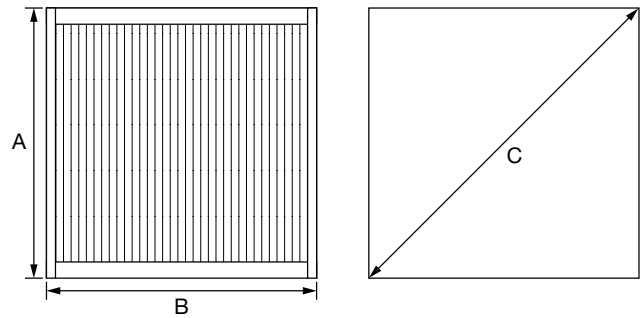

MODEL	A	B	C45*	C90**	PLATE DISTANCE
200	7.87	3.94-23.62	10.43	11.14	0.06/0.08/0.09/0.11
250***	9.84	3.94-23.62	10.43	11.14	0.06/0.08/0.09/0.11
300	11.81	3.94-23.62	15.98	16.69	0.07/0.09/0.12/0.16/0.2
415	16.34	7.87-27.56	21.57	23.11	3.3/4.2/5.0/6.5
425	16.73	7.87-39.37	23.11	23.66	3.3/4.2/5.0/6.5
490	19.29	9.84-39.37	26.65	27.28	2.8/3.3/4.2/5.0
600	23.62	9.84-47.24	32.84	33.43	0.11/0.12/0.18/0.24/0.30/0.35/0.41/0.47
750	29.53	11.81-47.24	40.99	41.77	0.13/0.18/0.24/0.30/0.35/0.41/0.47
800	31.49	11.81-47.24	-	44.53	0.13/0.18/0.24/0.30/0.35/0.41/0.47
850	33.45	11.81-47.24	46.54	47.32	0.12/0.14/0.16/0.20/0.26/0.30/0.32/0.37
1000	39.37	13.78-47.24	54.88	55.67	0.13/0.15/0.20/0.24/0.30/0.35/0.41/0.47
1200	47.24	13.78-47.24	66.02	66.81	0.11/0.12/0.18/0.24/0.30/0.35/0.41/0.47
1500	59.06	13.78-47.24	82.76	83.54	0.13/0.18/0.24/0.30/0.35/0.41/0.47
1700	66.93	13.78-47.24	93.86	94.65	0.12/0.16/0.18/0.20/0.26/0.34/0.41/0.47
2000	78.74	13.78-47.24	110.6	111.34	0.13/0.15/0.20/0.24/0.30/0.35/0.41/0.47
2250	88.58	13.78-47.24	124.5	125.28	0.13/0.18/0.24/0.30/0.35/0.41/0.47/0.47
2550	100.39	13.78-47.24	141.2	141.97	0.12/0.16/0.18/0.20/0.26/0.34/0.41/0.47
3000	118.11	13.78-47.24	166.3	167.05	0.20/0.24/0.30/0.35/0.41/0.47

\*45° corner profile.

\*\*90° corner profile.

\*\*\* only released for Thermal Management.

## CROSS FLOW HEAT EXCHANGER

# MODEL P

Extra Durable

Model P is a heavy duty, cross flow plate heat exchanger, specially designed for applications where high differential pressures occur. Efficiencies up to 65% for single units and up to 85% for two-step arrangements are typical.

Based on the same well-proven plate design as Model H, Model P's efficiency is similar but offers a higher differential pressure resistance due to its extra-strong aluminum plates.

Model P is our most robust aluminum cross flow plate heat exchanger.

All Heatex cross flow plate heat exchangers meet several hygiene requirements.



## TECHNICAL SPECIFICATIONS & OPTIONS

### PLATE MATERIAL:

- Aluminium
- Epoxy (for corrosion protection)

### CORNER PROFILE:

- 90° Aluminium
- 45° Aluminium
- Brush aluminum profile

### ENDPLATE:

- Aluzinc (for plate size > 23.62")

### MIN. ALLOWED TEMPERATURE:

- -104°F

### MAX. LEAKAGE:

- 0.1% of nominal airflow for size > 16.73" WC
- 1% of nominal airflow for sizes < 16.73" WC
- 1% of nominal airflow for all models with silicone sealant

### SEALING:

- Silicone free (max. 190°F)
- Silicone (max. 394°F)
- High temperature silicone (max. 464°F)

### ADDITIONAL OPTIONS:

- Product tightness test incl. report
- Painted framework (max. 190°F)
- Closed plate cutting edges (max. 190°F)
- ATEX testing
- Water tightness treatment
- Heatex damper

### MAX. ALLOWED DIFFERENTIAL PRESSURE:

- < 15" WC

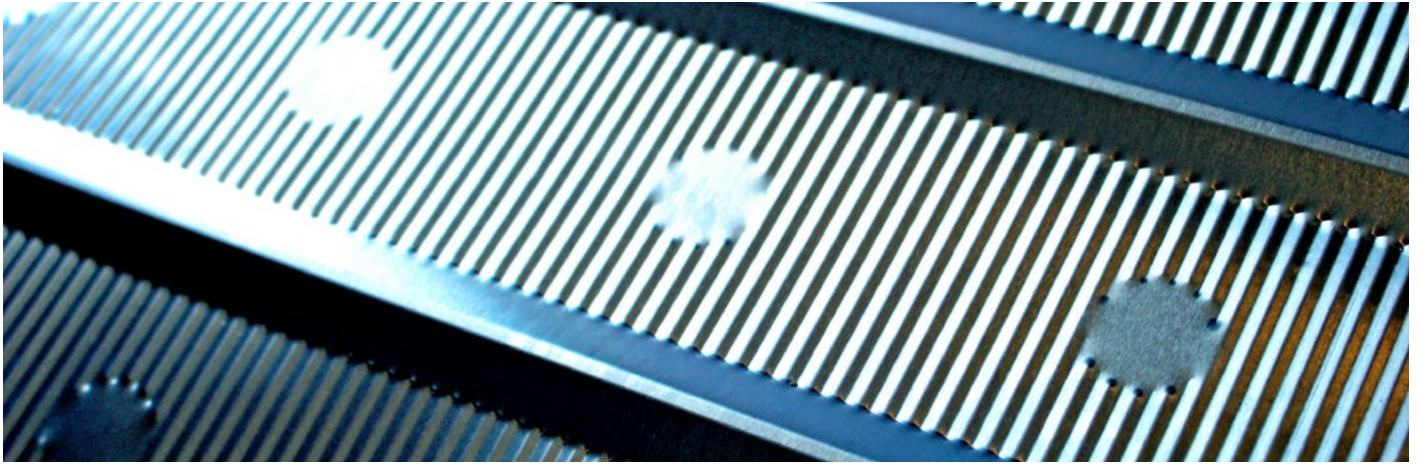

## MODEL P DIMENSIONS (INCH)

**COMBINED MODULES SIZE:**

- 23.62” - 118.11”

**PLATE SIZE:**

- 23.62”
- 29.53”
- 33.45”
- 39.37”

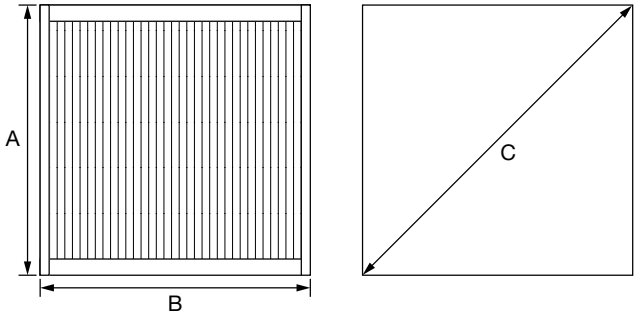

**NOTE:** Customized A-dimensions can to some extent be created with special corner profile designs.

MODEL	A	B	C45*	C90**	PLATE DISTANCE
600	23.62	9.84-47.24	32.64	33.43	0.11/0.13/0.18/0.24/0.30/0.35/0.41/0.47
750	29.53	11.81-47.24	40.99	41.77	0.13/0.18/0.24/0.30/0.35/0.41/0.47
850	33.45	11.81-47.24	46.57	47.32	0.12/0.14/0.16/0.20/0.26/0.31/0.37
1000	39.37	13.78-47.24	54.88	55.67	0.13/0.15/0.20/0.24/0.30/0.35/0.41/0.47
1200	47.24	13.78-47.24	-	66.81	0.11/0.13/0.18/0.24/0.30/0.35/0.41/0.47
1500	59.06	13.78-47.24	-	83.54	0.13/0.18/0.24/0.30/0.35/0.41/0.47
1700	66.93	13.78-47.24	-	94.65	0.12/0.14/0.16/0.20/0.26/0.31/0.37
2000	78.74	13.78-47.24	-	111.34	0.20/0.24/0.30/0.35/0.41/0.47
2250	88.58	13.78-47.24	-	125.28	0.13/0.18/0.24/0.30/0.35/0.41/0.47
2250	100.39	13.78-47.24	-	141.97	0.12/0.14/0.16/0.20/0.26/0.31/0.37
3000	118.11	13.78-47.24	-	167.05	0.20/0.24/0.30/0.35/0.41/0.47

\*45° corner profile.  
 \*\*90° corner profile.

CROSS FLOW HEAT EXCHANGER

# MODEL Z

**Extra Durable**

Model Z is designed to operate in corrosive environments and heavy duty applications. The entire unit is made of acid resistant stainless steel and a single pass exchanger can provide a sensible efficiency of 65 – 70%.

Based on the same well-proven plate design as Model H, Model Z's efficiency is similar to Model H but offers even higher differential pressure resistance due to its stainless steel plates. Model Z is our most durable cross-flow heat exchanger.

All Heatex cross flow plate heat exchangers meet several hygiene requirements.



## TECHNICAL SPECIFICATIONS & OPTIONS

**PLATE MATERIAL:**

- Acid resistant stainless steel 1.4404 (ASTM 316)

**CORNER PROFILE:**

- Acid resistant stainless steel 1.4404 (ASTM 316)

**ENDPLATE:**

- Acid resistant stainless steel 1.4404 (ASTM 316)

**SEALING:**

- Silicone free (max 190°F)
- Silicone (max. 394°F)
- High temperature silicone (max. 464°F)

**ADDITIONAL OPTIONS:**

- Product tightness test incl. report
- Painted framework (max. 190°F)
- Closed plate cutting edges (max. 190°F)
- Heatex damper
- Water tightness treatment

**MAX. LEAKAGE (IN %):**

- 0.1% of nominal airflow
- > 1% with silicone sealant

**MAX. ALLOWED DIFFERENTIAL PRESSURE:**

- < 16" WC

## DIMENSIONS (INCHES)

**COMBINED MODULES SIZE:**

- 23.62" & 47.24"

**PLATE SIZES:**

- 23.62"

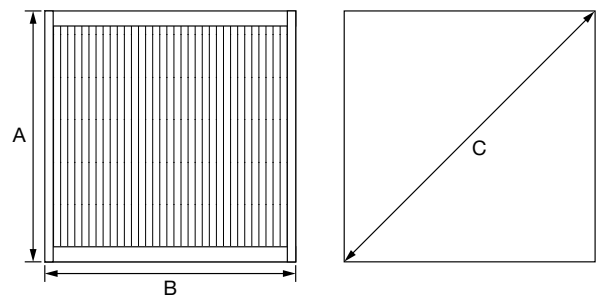

MODEL	A	B	C90*	PLATE DISTANCE
600	23.62	9.84-47.24	33.43	0.23 / 0.30 / 0.35
1200	47.24	13.78-47.24	66.81	0.23 / 0.30 / 0.35

\*90° corner profile.



## PLATE HEAT EXCHANGERS

# ADDITIONAL OPTIONS

### PAINTED FRAME WORK

Epoxy coated plates together with a painted framework will provide corrosion protection in wet and humid applications.

### CLOSED PLATE CUTTING EDGES

For ultimate corrosion protection, Heatex recommends cutting edges which means that a lacquer is run along the joints of the plates, covering the cutting edges found on epoxy coated plates.

### WATER TIGHTNESS TREATMENT

For complete water tightness Heatex offers a special treatment on most of our cross flow heat exchangers.

### PRODUCT TIGHTNESS TEST INCL. REPORT

For watertight exchangers, Heatex offers individual testing of each exchanger, including a test report.

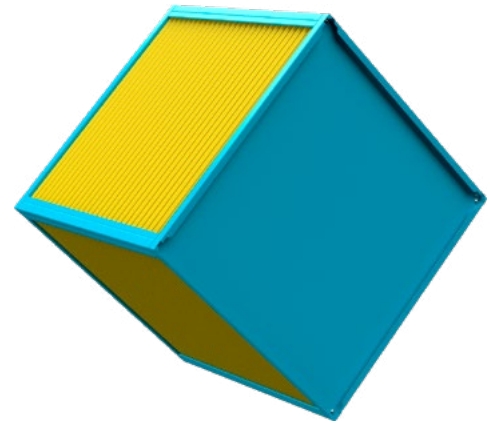

### DAMPERS

Suitable for close/open bypass exchanger section in connection with a cross-flow plate heat exchanger.

Tightness classification 2.

FRAME HEIGHT:

- 4.92"

WING WIDTH/ DIVISION:

- 3.94"

SQUARE SHAFT:

- 0.47" x 0.47"
- 1.97" in length

MAXIMUM DAMPER WIDTH:

- 98.43" (incl. bypass)

MAXIMUM DAMPER-UNIT AREA:

- 43.06 ft<sup>2</sup> (incl. bypass)

MAXIMUM WING LENGTH:

- 52.12"

MATERIAL:

- Profiles and damper wings in aluminium
- Driving wheels in PP plastic with fiberglass (suitable for temperatures between 5°F to 176°F)

Required Torque Nm/m<sup>2</sup>  
at pressure difference 1 500 Pa

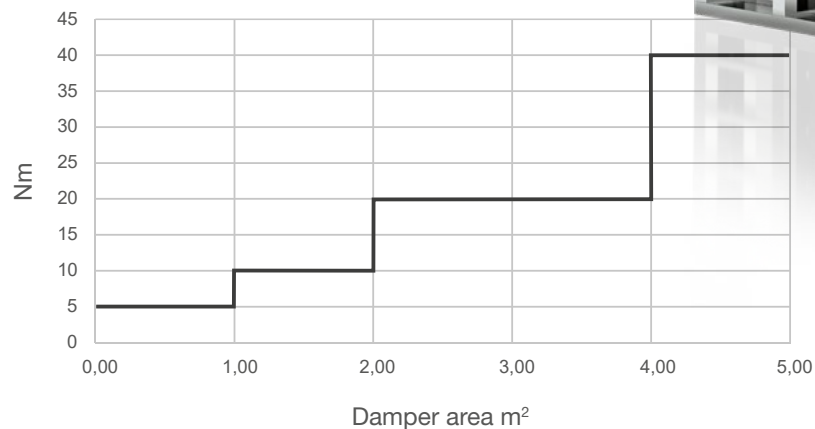

Values for 1 section + bypass-section. For each additional section add 3 Nm/m<sup>2</sup>.



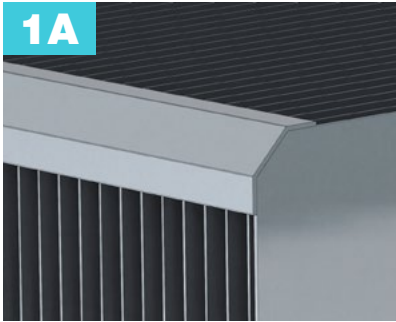

PLATE HEAT EXCHANGERS

# CORNER PROFILES

For further profile designs please contact us!

## PROFILES FOR FLAT ENDPLATE (FOR PLATE SIZES $\leq 16.34''$ )



45° aluminum profile

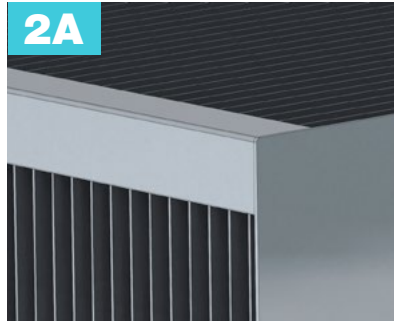

90° aluminum profile



Brush aluminum profile

## PROFILES FOR SINGLE BENT ENDPLATE (FOR PLATE SIZES $\geq 16.73''$ )



45° aluminum profile



90° aluminum profile



Brush aluminum profile

## PROFILES FOR DOUBLE BENT ENDPLATE (FOR PLATE SIZES $\geq 16.73''$ )



45° aluminum profile

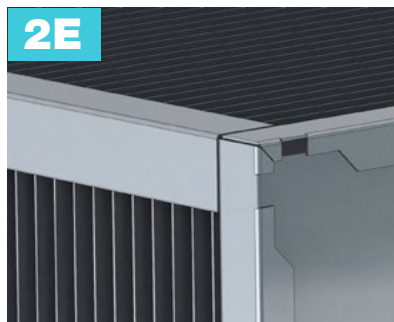

90° aluminum profile



Brush aluminum profile

## COUNTER FLOW HEAT EXCHANGER

# MODEL M

Slim & Efficient

Model M is a slim, high-efficiency counterflow plate heat exchanger, specially designed for the demanding requirements of the telecommunications and solar industry. Even in a dry situation, it can come close to 90% (sensible) efficiency.

Especially for Model M, Heatex offers custom integration solutions for easy installation and faster end product delivery. Model M is built according to customers' request with either double L-flow, double U-flow or L+U-flow configuration.

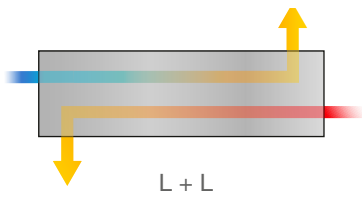

Most effective/recommended.

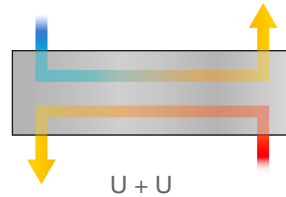

Alternative for special flow path requirements.

## TECHNICAL SPECIFICATIONS & OPTIONS

### PLATE MATERIAL:

- Aluminium
- Epoxy (for corrosion protection)

### CASING MATERIAL:

- Aluzinc

### MAX. ALLOWED TEMPERATURE AND SEALING:

- 190°F - Silicone free

### MAX. LEAKAGE:

- 0.1% of nominal air flow at 1.6" WC

### MAX. ALLOWED DIFFERENTIAL PRESSURE:

- 2.81" WC

## DIMENSIONS (INCHES)

### WIDTH/ LENGHT:

- 3.94" - 23.62"

### PLATE SIZE:

- 3.74"                      • 7.48"
- 5.51"                      • 9.28"

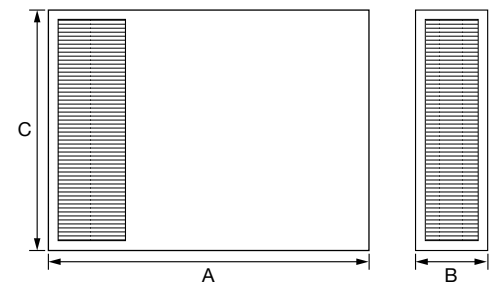

MODEL	A*	B	C	PLATE DISTANCE
200 - 500 x 95	7.87 - 19.69	3.74	3.94 - 23.62	0.12 / 0.18 / 0.27
300 - 600 x 140	11.81 - 23.62	5.51	3.94 - 23.62	0.12 / 0.18 / 0.27
400 - 1000 x 190	15.75 - 39.37	7.48	3.94 - 23.62	0.12 / 0.18 / 0.27 / 0.30
500 - 1000 x 235	19.69 - 39.37	9.25	3.94 - 27.56	0.12 / 0.18 / 0.27 / 0.30

\* Only available in 3.94 inches (100 mm) increments. For further options please contact us.



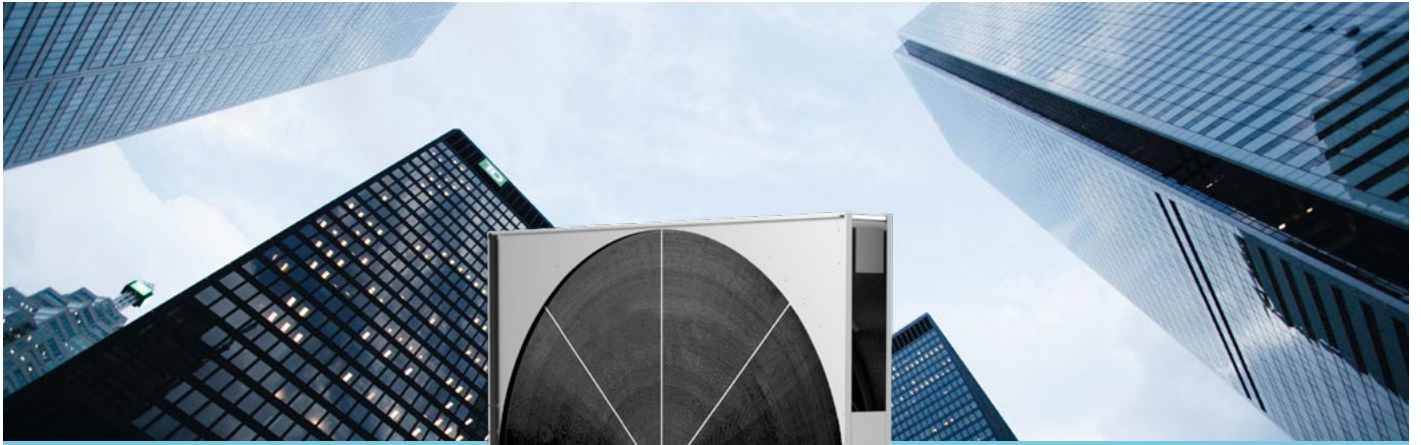

## ROTARY HEAT EXCHANGERS

All Heatex rotary heat exchangers share the same high-efficiency matrix and a wide variety of well-heights to suit various performance requirements. All units are produced at our global production facilities with our proprietary production equipment according to the same standardized processes, ensuring uniform product quality and favorable lead times worldwide.

### ADVANTAGES

---

- **HIGH EFFICIENCY**

Heatex rotary exchangers provide high sensible and latent efficiencies.

- **LOW FREEZING RISK**

Rotary heat exchangers offer a very low freezing risk as the wheels by definition defrost themselves.

- **MINIMAL CROSS CONTAMINATION**

Models with casing are fitted with seals for excellent air tightness and can be equipped with purge sectors to minimize the cross-contamination of exhaust air into the supply air.

- **HUMIDITY TRANSFER**

There are several possibilities to add various coatings to the wheel, to enable latent transfer or provide increased corrosion protection.

- **WIDE RANGE OF OPTIONS**

We offer an extensive range of options regarding sizes, material, and drives to suit various application and performance requirements.

- **FULLY CUSTOMISED**

All of our products are carefully designed to meet the demands for each specific application application and minimize the investment relative to the energy recovery need.

ROTARY HEAT EXCHANGERS

# COMPARE MODELS

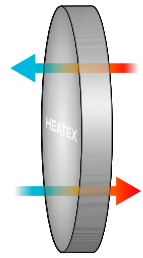

Every Model has a clear advantage depending on its application. All of our rotary heat exchangers share the same high-efficiency matrix. Model E offers one of the most compact casings on the market, whereas Model EQ features a segmented wheel for easy onsite installation or replacement in narrow spaces. Both wheels are also available without casing. Model EN is primarily designed for residential applications.

To determine which Model suits your application project, please use our comparison table below.

MODEL	E/O	EQ/EV	EN
<b>Airflow capacity</b>	125 - 56 000 CFM	1 170 - 110 000 CFM	30 - 1 177 CFM
<b>Rotor design</b>	One piece	Segmented	One piece
<b>Configuration</b>	Model E: With casing  Model O: Without casing	Model EQ: With casing  Model EV: Without casing	Without casing
<b>Exchanger orientation</b>	Vertical or horizontal	Vertical only	Vertical or horizontal
<b>Rotor diameter</b>	19.69" - 101.38" (Available in steps of 0.04" increments.)	47.24" - 149.61" (Available in steps of 0.04" increments.)	7.87" - 19" (Available in steps of 0.04" increments.)

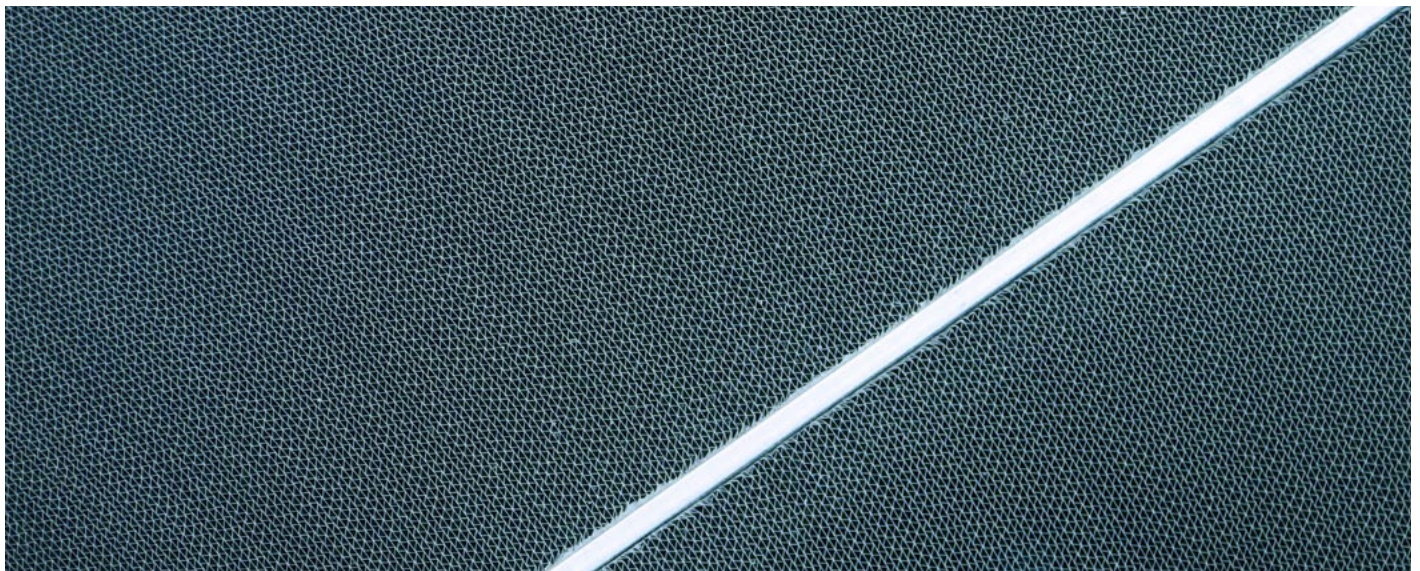

## ROTARY HEAT EXCHANGER

# MODEL E & O

### Compact Casing

Model E is a high-performing and lightweight rotary heat exchanger designed for air handling units, primarily for comfort ventilation applications. Typical temperature efficiencies are up to 90%.

Model E offers one of the most compact galvanized steel casings available on the market. This gives an exceptional efficiency compared to conventional rotary exchangers with the same casing dimensions.

Model E's performance is certified according to AHRI. Model E also meets several hygiene requirements.

Only the wheel, without casing, is called Model O.



## TECHNICAL SPECIFICATIONS & OPTIONS

### MATRIX MATERIAL:

- Aluminum (Condensation)
- Epoxy (Condensation)
- Hybrid with silica gel (Enthalpy)
- Hybrid with molecular sieve (Enthalpy)
- Silica gel (Adsorption)
- Molecular sieve (Adsorption)

### EXCHANGER ORIENTATION:

- Vertical
- Horizontal

### HUB:

- Ball bearing with shaft
- Ball bearing with shaft, corrosion resistant

### CASING TYPE:

- Standard
- Covered

### AIRFLOW CAPACITY:

- 125 - 56 000 CFM

### MAX. ALLOWED PRESSURE DROP:

- 1.2" WC for below diameter 63"
- 1.0" WC for larger than diameter 63"

### SEAL:

- Brush seal
- Special seal

### CASING OPTIONS:

- Painted framework
- Inspection hatches
- Cable glands
- Condensate tray
- Hygienic certified casing

### DRIVE EQUIPMENT:

- Constant drive 3x380-420V
- Constant drive 3x220-240V
- Varimax step drive
- NG Varimax step drive with Modbus
- OJ step drive with Modbus
- Rotation detector

### DRIVE BELT:

- Round belt
- Power belt

### RECOMMENDED VALUES FOR ALL ROTARY HEX:

- Maximum differential pressure up to 2.40" WC
- Recommended pressure drop between 0.40" - 0.80" WC
- Air temperature limits between min. -40°F and max. 149°F



## MODEL E & O DIMENSIONS (INCHES)

**NOTE:**

Rotor diameter is available in 0.04" increments.  
 Non-standard casing dimensions available.

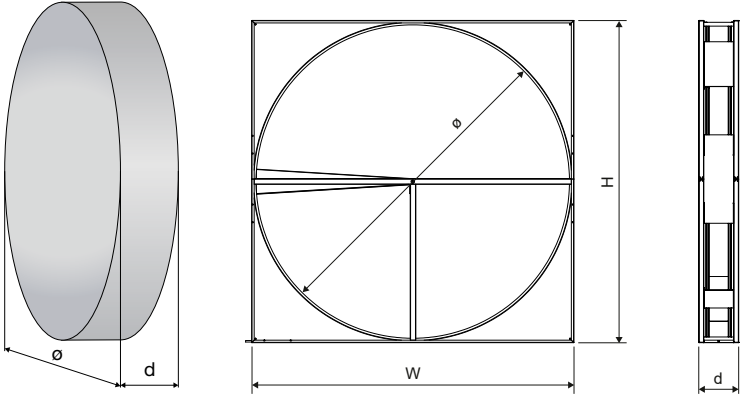

ROTOR		CASING		
DIAMETER (Ø)	FRONT (VARIABLE MOTOR)	FRONT (CONSTANT DRIVE)	DEPTH (d)	WELL HEIGHT VERSION**
19.69	21.65 x 21.65	23.62 x 23.62	10.87	0.055 / 0.063 / 0.071 / 0.079 / 0.087 / 0.098
23.62	25.59 x 25.59	27.56 x 27.56	10.87	0.055 / 0.063 / 0.071 / 0.079 / 0.087 / 0.098
27.56	29.53 x 29.53	31.50 x 31.50	10.87	0.055 / 0.063 / 0.071 / 0.079 / 0.087 / 0.098
31.50	33.46 x 33.46	35.43 x 35.43	10.87	0.055 / 0.063 / 0.071 / 0.079 / 0.087 / 0.098
35.43	37.40 x 37.40	39.37 x 39.37	10.87	0.055 / 0.063 / 0.071 / 0.079 / 0.087 / 0.098
39.37	41.34 x 41.34	43.31 x 43.31	10.87	0.055 / 0.063 / 0.071 / 0.079 / 0.087 / 0.098
43.31	45.28 x 45.28	47.24 x 47.24	10.87	0.055 / 0.063 / 0.071 / 0.079 / 0.087 / 0.098
47.24	49.21 x 49.21	49.21 x 49.21	12.44	0.055 / 0.063 / 0.071 / 0.079 / 0.087 / 0.098
51.18	53.15 x 53.15	53.15 x 53.15	12.44	0.055 / 0.063 / 0.071 / 0.079 / 0.087 / 0.098
55.12	57.09 x 57.09	57.09 x 57.09	12.44	0.055 / 0.063 / 0.071 / 0.079 / 0.087 / 0.098
59.06	61.02 x 61.02	61.02 x 61.02	12.44	0.055 / 0.063 / 0.071 / 0.079 / 0.087 / 0.098
62.99	64.96 x 64.96	64.96 x 64.96	12.44	0.055 / 0.063 / 0.071 / 0.079 / 0.087 / 0.098
66.93	68.90 x 68.90	68.90 x 68.90	12.44	0.055 / 0.063 / 0.071 / 0.079 / 0.087 / 0.098
70.87	72.83 x 72.83	72.83 x 72.83	12.44	0.055 / 0.063 / 0.071 / 0.079 / 0.087 / 0.098
74.80	76.77 x 76.77	76.77 x 76.77	12.44	0.055 / 0.063 / 0.071 / 0.079 / 0.087 / 0.098
78.74	80.71 x 80.71	80.71 x 80.71	12.44	0.055 / 0.063 / 0.071 / 0.079 / 0.087 / 0.098
82.68	84.65 x 84.65	84.65 x 84.65	12.44	0.055 / 0.063 / 0.071 / 0.079 / 0.087 / 0.098
86.61	88.58 x 88.58	88.58 x 88.58	12.44	0.055 / 0.063 / 0.071 / 0.079 / 0.087 / 0.098
90.55	92.52 x 92.52	92.52 x 92.52	12.44	0.055 / 0.063 / 0.071 / 0.079 / 0.087 / 0.098
94.49	96.46 x 96.46	96.46 x 96.46	12.44	0.055 / 0.063 / 0.071 / 0.079 / 0.087 / 0.098
98.43	100.39 x 100.39	100.40 x 100.40	12.44	0.055 / 0.063 / 0.071 / 0.079 / 0.087 / 0.098

\* Other dimensions available on request.

\*\* The exact well height depends on the thickness of the material selected. See technical manual for exact dimensions.

## ROTARY HEAT EXCHANGER

# MODEL EQ & EV

### Segmented Rotor

Model EQ is a high-performing, segmented rotary heat exchanger in a robust galvanized steel casing for industrial and marine ventilation applications. Typical temperature efficiencies are up to 90%.

Thanks to its segmented wheel, Model EQ facilitates onsite installation or replacement in narrow spaces. It also provides for lower transportation costs. It is possible to make adjustments to the position of the shaft in all directions for a perfectly balanced fit in the air handling unit.

Model EQ is certified according to AHRI.

Only the wheel, without casing, is called Model EV.

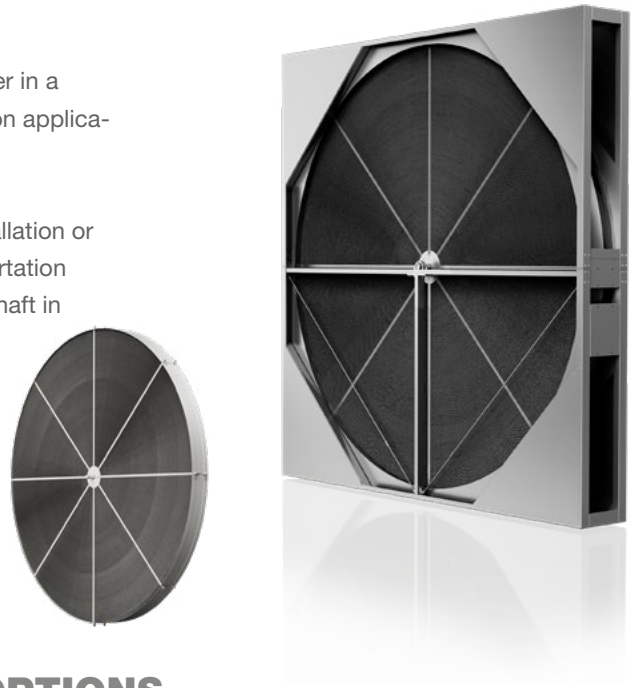

## TECHNICAL SPECIFICATIONS & OPTIONS

### MATRIX MATERIAL:

- Aluminum (Condensation)
- Epoxy (Condensation)
- Hybrid with silica gel (Enthalpy)
- Hybrid with molecular sieve (Enthalpy)
- Silica gel (Adsorption)
- Molecular sieve (Adsorption)

### EXCHANGER ORIENTATION:

- Vertical only

### HUB:

- External bearing with fixed shaft
- Ball bearing with shaft, corrosion resistant

### CASING TYPE:

- Standard
- Covered

### AIRFLOW CAPACITY:

- 1 170 - 110 000 CFM

### MAX. ALLOWED PRESSURE DROP:

- 1" WC

### CASING OPTIONS:

- Painted framework
- Inspection hatches
- Cable glands
- Condensate tray
- Hygienic certified casing
- Insulated casing

### DRIVE EQUIPMENT:

- Drive and control (VFD)
- Inverter ready constant drive
- Rotation detector

### DRIVE BELT:

- Power belt

### SEAL:

- Brush seal

### RECOMMENDED VALUES FOR ALL ROTARY HEX:

- Maximum differential pressure up to 2.40" WC
- Recommended pressure drop between 0.40" - 0.80" WC
- Air temperature limits between min. -40°F and max. 149°F





## MODEL EQ & EV DIMENSIONS (INCHES)

**NOTE:**

Rotor diameter is available in 0.04" increments.  
 Non-standard casing dimensions available.

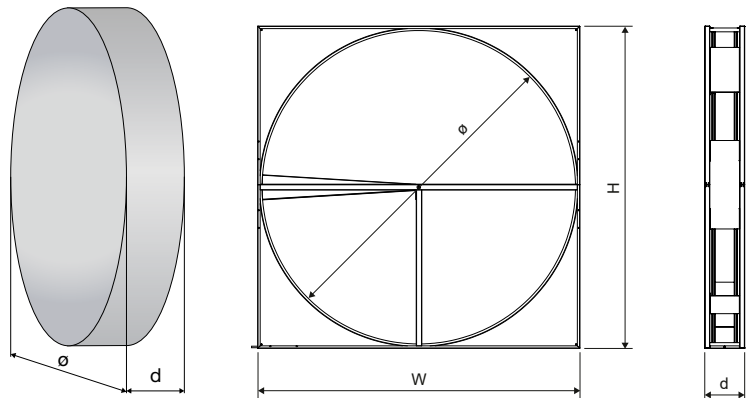

ROTOR DIAMETER (Ø)	CASING		
	FRONT	DEPTH (d)	WELL HEIGHT VERSION**
62.99	68.50x68.50	17.95	0.055 / 0.063 / 0.071 / 0.079 / 0.087 / 0.098
66.93	72.44x72.44	17.95	0.055 / 0.063 / 0.071 / 0.079 / 0.087 / 0.098
70.87	76.38x76.38	17.95	0.055 / 0.063 / 0.071 / 0.079 / 0.087 / 0.098
74.80	80.31x80.31	17.95	0.055 / 0.063 / 0.071 / 0.079 / 0.087 / 0.098
78.74	84.25x84.25	18.11	0.055 / 0.063 / 0.071 / 0.079 / 0.087 / 0.098
82.68	88.19x88.19	18.11	0.055 / 0.063 / 0.071 / 0.079 / 0.087 / 0.098
86.61	92.13x92.13	18.11	0.055 / 0.063 / 0.071 / 0.079 / 0.087 / 0.098
90.55	96.06x96.06	18.11	0.055 / 0.063 / 0.071 / 0.079 / 0.087 / 0.098
94.49	100.00x100.00	18.11	0.055 / 0.063 / 0.071 / 0.079 / 0.087 / 0.098
98.43	103.94x103.94	18.11	0.055 / 0.063 / 0.071 / 0.079 / 0.087 / 0.098
102.36	107.87x107.87	18.11	0.055 / 0.063 / 0.071 / 0.079 / 0.087 / 0.098
106.30	111.81x111.81	18.11	0.055 / 0.063 / 0.071 / 0.079 / 0.087 / 0.098
110.24	115.75x115.75	18.11	0.055 / 0.063 / 0.071 / 0.079 / 0.087 / 0.098
114.17	119.69x119.69	19.69	0.055 / 0.063 / 0.071 / 0.079 / 0.087 / 0.098
118.11	123.62x123.62	19.69	0.055 / 0.063 / 0.071 / 0.079 / 0.087 / 0.098
122.05	127.56x127.56	19.69	0.055 / 0.063 / 0.071 / 0.079 / 0.087 / 0.098
125.98	131.50x131.50	19.69	0.055 / 0.063 / 0.071 / 0.079 / 0.087 / 0.098
129.92	135.43x135.43	19.69	0.055 / 0.063 / 0.071 / 0.079 / 0.087 / 0.098
133.86	139.37x139.37	19.69	0.055 / 0.063 / 0.071 / 0.079 / 0.087 / 0.098
137.80	143.31x143.31	19.69	0.055 / 0.063 / 0.071 / 0.079 / 0.087 / 0.098
141.73	147.24x147.24	19.69	0.055 / 0.063 / 0.071 / 0.079 / 0.087 / 0.098
145.67	151.18x151.18	19.69	0.055 / 0.063 / 0.071 / 0.079 / 0.087 / 0.098
149.61	155.12x155.12	19.69	0.055 / 0.063 / 0.071 / 0.079 / 0.087 / 0.098

\*Other wheel dimensions (between 62.99" and 149.61") are available upon request. Larger casings than minimum are possible.

\*\* The exact well height depends on the thickness of the material selected. See technical manual for exact dimensions.

## ROTARY HEAT EXCHANGER

# MODEL EN

### Several Wheel Widths

Model EN is a high-performing small rotary heat exchanger without casing, designed to be fitted directly inside an air handling unit or mounted in a cassette, primarily for residential ventilation applications. Typical temperature efficiencies are between 75-80%, but with design optimization, the efficiency can approach 90%.

The product holds a smaller diameter hub and bearing, which maximizes the airflow for small residential air handlers. Further, glued aluminum wrapping allows for high output and durability. Model EN is available in different depths, adding one more dimension for perfection in residential air handling design.



## TECHNICAL SPECIFICATIONS & OPTIONS

### MATRIX MATERIAL:

- Aluminum (Condensation)
- Epoxy (Condensation)
- Hybrid with silica gel (Enthalpy)
- Hybrid with molecular sieve (Enthalpy)
- Silica gel (Adsorption)
- Molecular sieve (Adsorption)

### AIRFLOW CAPACITY:

- 30 - 1 177 CFM

### MAX. ALLOWED PRESSURE DROP:

- 1.2" WC

### EXCHANGER ORIENTATION:

- Vertical
- Horizontal

### HUB:

- Ball bearing with shaft

### RECOMMENDED VALUES FOR ALL ROTARY HEX:

- Maximum differential pressure up to 2.40" WC
- Recommended pressure drop between 0.40" - 0.80" WC
- Air temperature limits between min. -40°F and max. 149°F

## DIMENSIONS (INCHES)

DIAMETER (Ø)	DEPTH (d)	WELL HEIGHT VERSION*
7.87 - 19.69	3.94 / 5.91 / 7.87	0.05** / 0.06 / 0.07 / 0.08

\* The exact well height depends on the thickness of the material selected.

\*\* Only available in Aluminum, Epoxy and Hybrid.

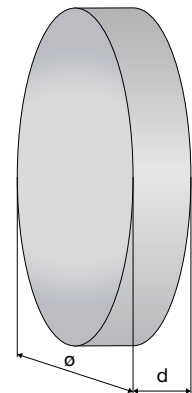

## ROTARY HEAT EXCHANGERS

# CASING OPTIONS

### PAINTED FRAMEWORK

Some applications require improved corrosion protection (e.g., marine environments).

A painted framework combined with an epoxy coated wheel and corrosion-resistant ball bearings increases the corrosion resistance significantly.



### INSPECTION HATCHES, CABLE GLANDS & CONDENSATE TRAY

For easier access to the motor we provide optional hatches and cable glands.

For humid climates, we recommend adding a condensate tray to collect water and lead it out of the AHU.

The covered casing automatically comes with inspection hatches and cable glands to enable access to otherwise closed-off components.

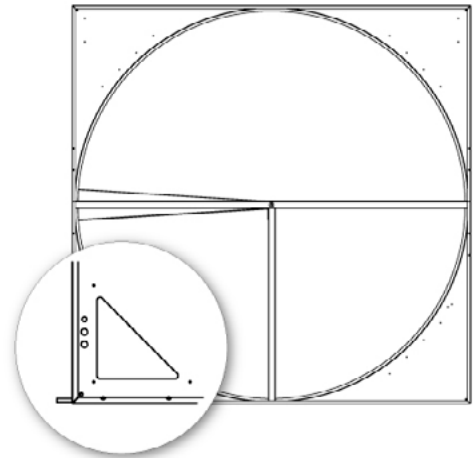

### PURGE SECTOR AND SPECIAL SEAL

Models with casing can be equipped with special seals and a purge sector to minimize the cross-contamination of exhaust air into the supply air.

The purge sector is optimized to reduce carryover or EATR. It will stop the inlet of exhaust air in the small area right before the airflows switch, thus avoiding exhaust air from getting trapped into the matrix.

A small amount of the supply air is used to blow out the minor amount of exhaust air that might have been trapped to ensure a fresh and clean air supply.

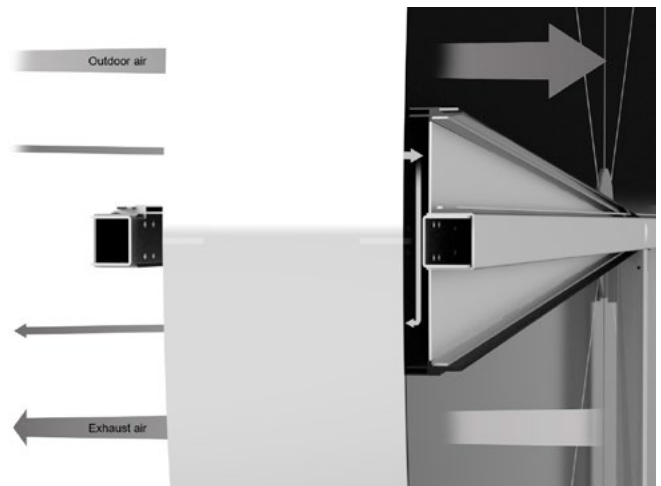



**HEAT EXCHANGER CALCULATION**

# PRODUCT SELECTION

Heatex Select, our calculation software, enables accurate calculations of our product performance under different conditions and the energy-saving potential in various geographical zones.

Heatex Select is always available online for free at [heatex.com](http://heatex.com).

All heat transfer and pressure drop calculations are done with the actual heat exchanger geometry and based on correlation from scientifically well-renowned sources such as the "International Hand Book of Heat Exchanger Design".

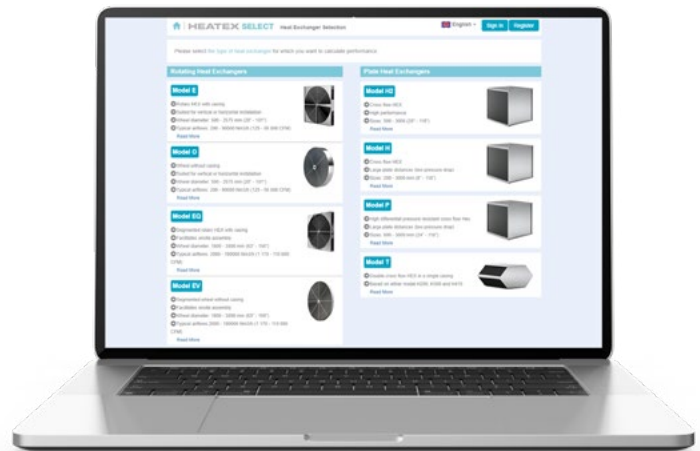

**HEATEX SELECT**



**SAVING ENERGY & RESOURCES**

# RETURN ON INVESTMENT



A heat exchanger is almost always a beneficial investment – regardless of whether the exchanger is a rotary or a plate heat exchanger.

By recovering heat, energy consumption is reduced. Saved energy cut costs and the consumption of coal, natural gas, and other fossil fuels, which eventually leads to carbon dioxide reduction.

All our models save sufficient energy to provide short amortization periods and valuable savings.

In Heatex Select Online, you find a return on investment calculator that approximately indicates the payback amount and time as well as energy saved by installing a Heatex air-to-air heat exchanger.



## MANUFACTURING & LOGISTICS

# PRODUCTION

Strategically located production facilities in Europe, the US, and China enable us to respond to regional product variations and demand as quickly as possible while assuring stable supply lines and highly trained staff.

Heatex' Lean Manufacturing certified personnel constantly manage towards perfection to reduce the number of steps, time, and information needed to serve our customers. By assuring efficient processes and reliable suppliers, we constantly aim to optimize production, reduce scrap and secure stable lead times, resulting in high-quality products with a competitive price and a minimal carbon footprint.

### HEALTH AND SAFETY

Every Heatex production plant meets and goes beyond all relevant legislative requirements set out by the national government in each country to make sure its personnel is safe and sound.

In case of any accidents, the incident is registered, investigated, and analyzed. Preventive measures are put in place to eliminate any further issues.

### ENVIRONMENTAL FOCUS

We are ourselves equally committed to improve and reinvent our manufacturing to pollute less and create less overall production waste.

All materials used during production are responsibly sourced and recycled. In addition, the production of scrap metal is minimized through continuous improvements in the production process.

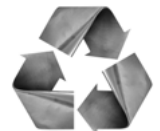



# HEATEX

## THE PROMISE: HIGH QUALITY PRODUCTS

Heatex holds several certifications covering product and operation quality worldwide. Our products are field-tested and designed to comply with all relevant building codes and regulations. We frequently send our products to independent labs worldwide for inspection, and we have our in-house test rig to evaluate product performance regularly.

## THE PROOF: OUR REPUTATION & CERTIFICATIONS

We have a well-established reputation of being honest, reliable and hold several certifications for product and operation quality worldwide, including Eurovent, AHRI, and ISO 9001. Our products are field-tested and proven to have high efficiency and a fast ROI.

All Heatex products are custom made and designed to match each customer's technical specifications, and every site has its engineering team to respond to regional differences quickly.

**Visit [heatex.com/us](http://heatex.com/us) for more information.**



MEETING MINUTES

# YOUR NOTES

# HEATEX

**The Air-to-Air Heat Transfer Specialist**