

HEATEX MODEL E

INSTALLATION & MAINTENANCE

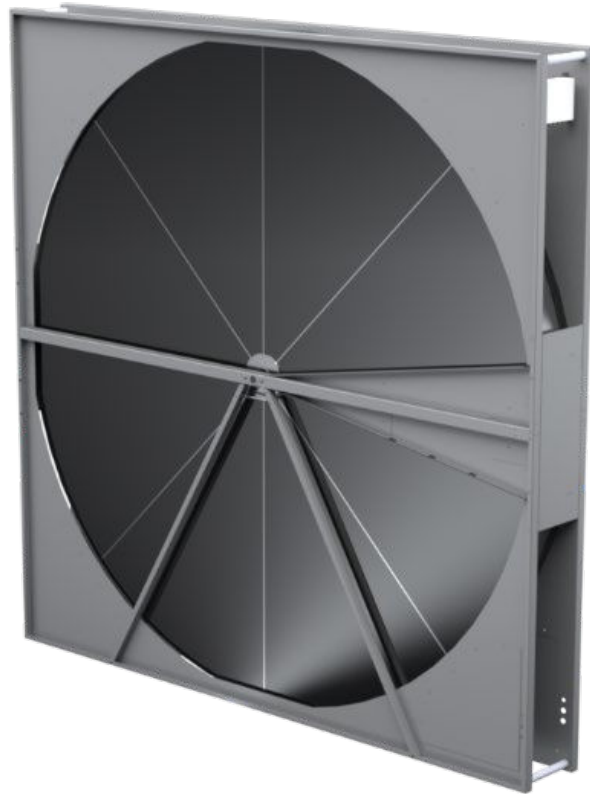

Version 1 Updated 01-06-2026

Heatex AB
Hyllie Boulevard 34
215 32 Malmö, Sweden

Telephone: +46 410 710 500

info@heatex.com
www.heatex.com

DISCLAIMER

Information in this document (including URL references and information from other external sources referred herein) is subject to change without notice. Owing to continued product development, Heatex reserves the right to introduce alterations in both design and prices without prior notice.

THIS DOCUMENT IS PROVIDED "AS IS" WITH NO EXPRESSED OR IMPLIED WARRANTIES WHATSOEVER, INCLUDING ANY WARRANTY OF MERCHANTABILITY, NON-INFRINGEMENT, FITNESS FOR ANY PARTICULAR PURPOSE, OR OTHERWISE ANY WARRANTY ARISING OUT OF ANY PROPOSAL, SPECIFICATION OR SAMPLE. ALL LIABILITY, INCLUDING LIABILITY FOR INFRINGEMENT OF ANY PROPRIETARY RIGHTS, RELATING TO USE OF INFORMATION CONTAINED OR REFERENCED IN THIS DOCUMENT IS HEREBY EXPRESSLY DISCLAIMED.

COPYRIGHT NOTICE

All information and content included (whether directly or by reference) in this document, such as text, graphics and images, is the property of Heatex AB, its subsidiaries, affiliates, licensors and/or joint venture partners. All rights are reserved.

No licenses, express, implied or otherwise to any intellectual property rights in this document are granted by Heatex AB.

This disclaimer and copyright notice is subject to and governed by Swedish law.

Copyright © 2026

Heatex AB

DECLARATION OF INCORPORATION

Description and identification of the partly completed machinery:
Rotary heat exchanger model E with casing and with a drive unit.

The following essential requirements of EC Machinery Directive 2006/42/EC have been applied and fulfilled:
1.1.2, 1.2.1, 1.2.3, 1.2.4.1, 1.2.4.2, 1.2.4.3, 1.2.6, 1.3.1, 1.3.2, 1.3.4, 1.3.7, 1.3.8, 1.3.8.1, 1.3.8.2, 1.4.1, 1.4.2.1, 1.4.2.2, 1.4.2.3, 1.4.3, 1.5.1, 1.5.2, 1.5.4, 1.5.5, 1.5.6, 1.6.1, 1.6.3, 1.7.1, 1.7.3, 1.7.4, 1.7.4.1, 1.7.4.2, 1.7.4.3

The relevant technical documentation has been compiled in accordance with Annex VII, Part B of EC Machinery Directive 2006/42/EC. We undertake, in response to a reasoned request, to supply it in electronic form to the market surveillance authorities within a reasonable period.

The party authorized to compile the technical documentation is: Johan Gidner, R&D Manager.

The partly completed machinery must not be put into service until the final machinery into which it is to be incorporated has been declared in conformity with the provisions of the Machinery Directive.

Malmö, 2025-11-11

CONTENT

| | | |
|-----------|--|-----------|
| 1 | GENERAL | 4 |
| 2 | AT DELIVERY | 4 |
| 2.1 | TRANSPORT | 4 |
| 3 | STORAGE | 5 |
| 4 | INSTALLATION | 5 |
| 5 | PRE-START ADJUSTMENTS AND INSPECTIONS | 8 |
| 6 | MAINTENANCE | 8 |
| 6.1 | MATRIX | 8 |
| 6.2 | ADSORPTION AND ENTHALPY WHEELS | 9 |
| 6.3 | POWER BELT | 9 |
| 6.4 | ROUND BELT | 10 |
| 6.5 | BRUSH SEALINGS | 10 |
| 6.6 | SPECIAL SEALS | 10 |
| 6.7 | PURGE SECTOR | 10 |
| 6.8 | CONTROL UNIT | 11 |
| 6.9 | ROTOR TILT | 11 |
| 6.10 | MOTOR ACCESS | 11 |
| 6.11 | APPLICATION LIMITS | 12 |
| 6.12 | TROUBLESHOOTING | 12 |
| 6.13 | CONDITIONS TO FULFILL THE HYGIENE CERTIFICATION REQUIREMENTS | 13 |
| 7 | BELT REPLACEMENT | 14 |
| 7.1 | BELT REPLACEMENT STEP 1 | 14 |
| 7.2 | BELT REPLACEMENT STEP 2 | 15 |
| 8 | MOTOR REPLACEMENT | 16 |
| 8.1 | MOTOR REPLACEMENT STEP 1 | 16 |
| 8.2 | MOTOR REPLACEMENT STEP 2 | 16 |
| 8.3 | MOTOR REPLACEMENT STEP 3 | 17 |
| 8.4 | MOTOR REPLACEMENT STEP 4 | 17 |
| 8.5 | MOTOR REPLACEMENT STEP 5 | 18 |
| 8.6 | MOTOR REPLACEMENT STEP 6 | 18 |
| 8.7 | MOTOR REPLACEMENT STEP 7 | 19 |
| 9 | CONTROLLER REPLACEMENT | 20 |
| 9.1 | CONTROLLER REPLACEMENT STEP 1 | 20 |
| 9.2 | CONTROLLER REPLACEMENT STEP 2 | 20 |
| 9.3 | CONTROLLER REPLACEMENT STEP 3 | 21 |
| 9.4 | CONTROLLER REPLACEMENT STEP 4 | 21 |
| 9.5 | CONTROLLER REPLACEMENT STEP 5 | 22 |
| 9.6 | CONTROLLER REPLACEMENT STEP 6 | 22 |
| 9.7 | CONTROLLER REPLACEMENT STEP 7 | 23 |
| 10 | APPENDIX | 24 |

1 GENERAL

A rotary heat exchanger with casing and drive is “partly completed machinery” as defined in Directive 2006/42/EC. This product is delivered in compliance with the Directive 2006/42/EC but when installed in the complete machinery it is up to the installer to make sure that the final product complies with the directive.

Special attention should be paid to sharp edges (risk of cuts) and that when the wheel is rotating the rotating parts may cause injuries. The surfaces of the drive motor and gear can be hot and attention should be paid to the risk of burn injuries. The sound level from the heat exchanger is less than 70 dB (A).

2 AT DELIVERY

Before installation, the following should be checked:

1. Check if there are any signs of transportation damage before accepting the goods.
2. Has the right exchanger been delivered? Check type, design, size and options.¹
3. How is the exchanger to be positioned?
4. In case of any damage, please report this in writing by email as soon as possible.

2.1 Transport

5. Always transport the exchanger vertically.
6. Lift the exchanger in the upper two corner distance pipes according to Picture 1. If the casing is covered, please lift at the gables according to Picture 2.
7. It is important that all transport and handling is carried out by qualified staff.

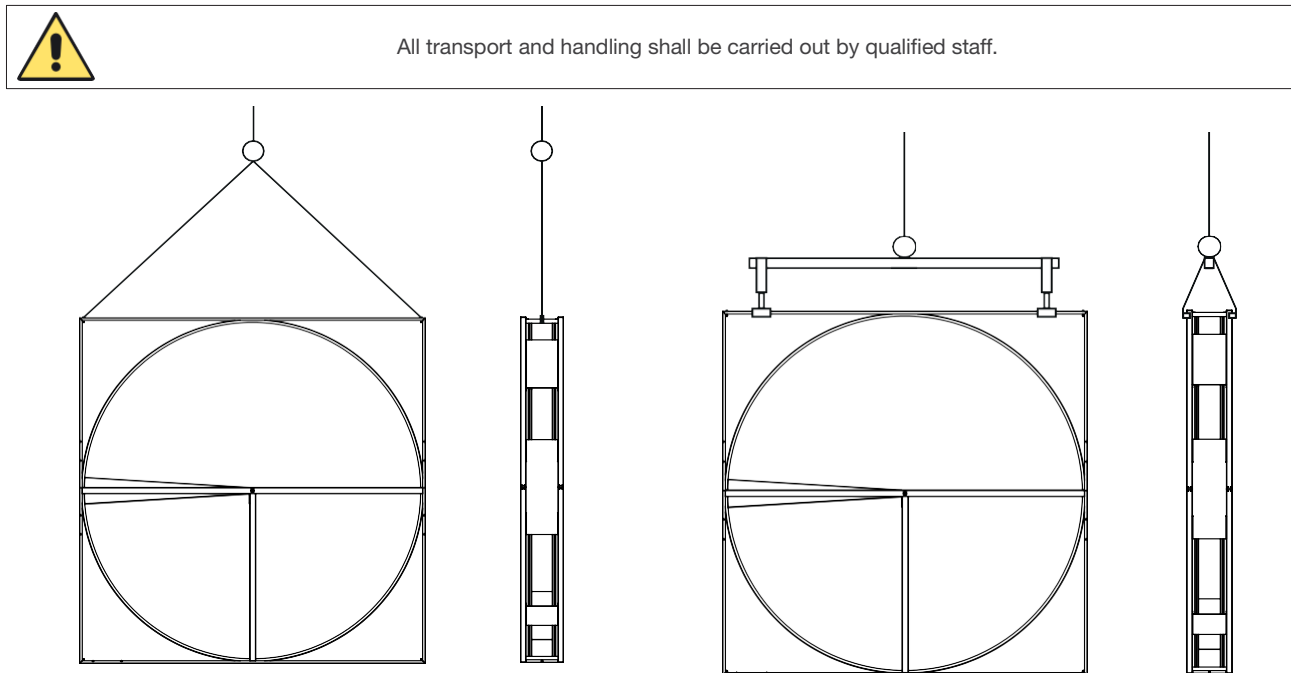

Picture 1. Lift the casing at the corner distance pipes. Picture 2. If the casing is covered, lift the casing at the gables.

¹ Please note that for diameters between 500 mm (19.69”) and 900 mm (35.43”) the controller of the variable drive unit will be delivered separately.

3 STORAGE

Aluminum wheels are sensitive for corrosion, epoxy wheels to sunlight. Hybrid and adsorption wheels, to moisture. Make sure rotors are stored according to the conditions described above.

Furthermore, the unit is to be placed on a horizontal and even surface. Please note that an uneven surface can warp the rotor and affect the factory adjustments.

Always make sure that the heat exchanger is supported and secured during transport, handling, storage and installation so it cannot fall over and cause damage or injuries.



Heat exchanger may fall over if not secured.

Please observe that there may be sharp edges and a risk for cuts so we recommend that gloves should be used when the heat exchanger is handled.



Use gloves when handling the heat exchanger.

Always make sure that the storage temperature is kept above 0°C (32°F).

Rotors without casing (Model O), must be stored fully supported lying horizontally (as delivered) or hanging by their shaft.

4 INSTALLATION

When designing the air handling unit (AHU onwards) and/or duct system, the system designer needs to make sure it is possible to remove/pull out the heat exchanger for inspection, maintenance, service, cleaning and disinfection. (Furthermore, the system designer needs to consider enough space inside and outside of the system to make sure that it is possible to remove/pull out the heat exchanger).

For bigger heat exchanger units it is required to add doors or hatches on all sides in the AHU and/or duct system making it possible to access the heat exchanger for inspection, maintenance, service, cleaning and disinfection.

In case condensate is present, it is required by the designer of the air handling unit and/or duct system, to design and install a condensation tray according to the norm VDI 6022, chapter 4.3.16

The casing is a slide-in solution that requires a sturdy structure from the surrounding AHU. The AHU should not be able to flex more than ± 1 mm. in any position specified in picture 3, while being subject to the maximum force shown in table 3.

Please refer to Picture 3 for the force schedule and Picture 4 for the specific support positions. Pay extra attention to position 3, as it experiences significant forces during operation.

Ensure the rotor is installed on a horizontal, even surface to prevent warping and maintain factory settings.

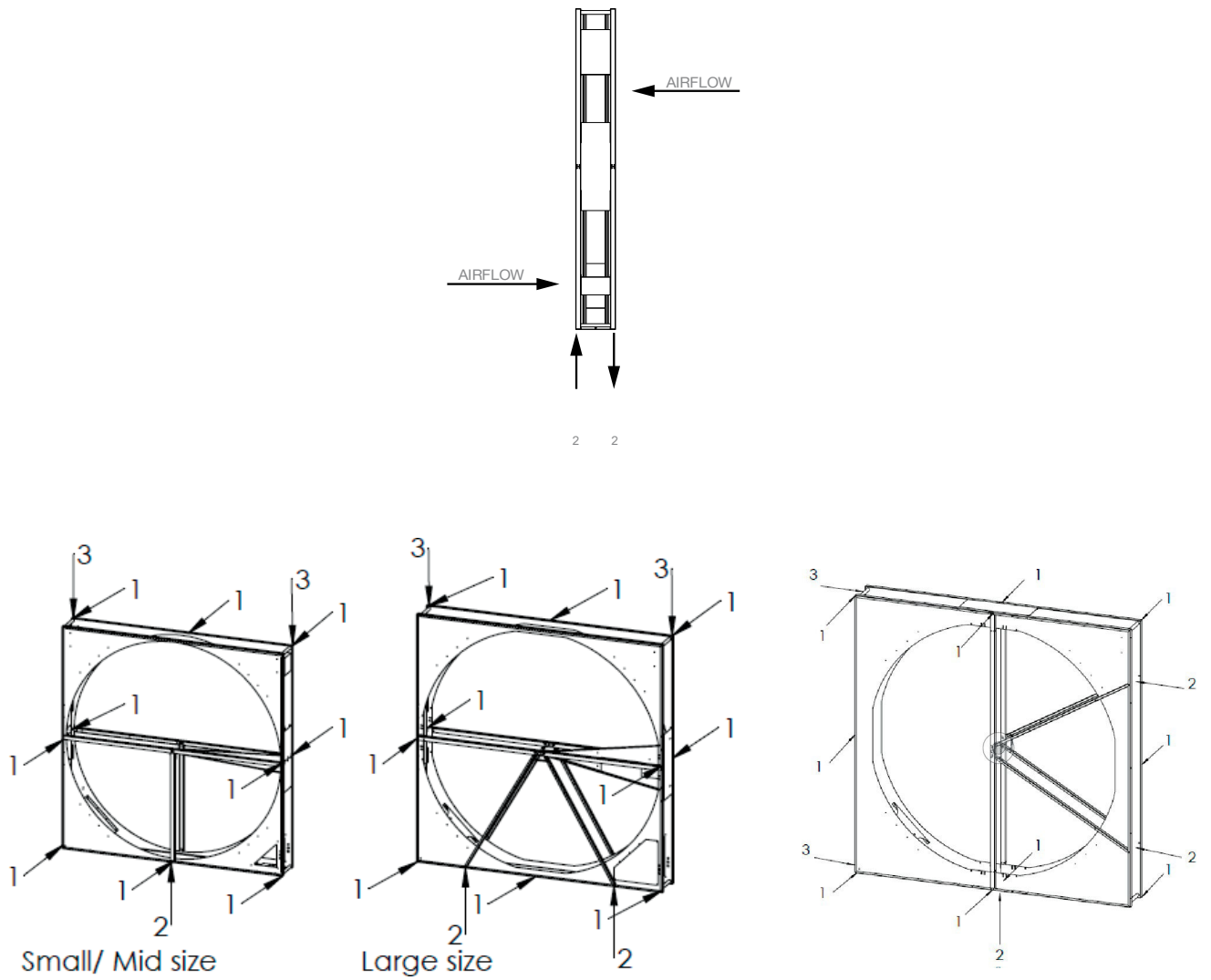

Picture 3. Force schedule. Over and under (left two images) & side by side (right image).

| Force | Direction of force | Ø500 -1100 | Ø1101-1500 | Ø1501-2575 |
|-------|---------------------|------------|------------|------------|
| 1 | Against the airflow | 0.4 kN | 0.5 kN | 0.7 kN |
| 2 | Vertically up | 2 kN | 5 kN | 5 kN |
| 3 | Vertically down/up | 0.5 kN | 0.6 kN | 0.8 kN |

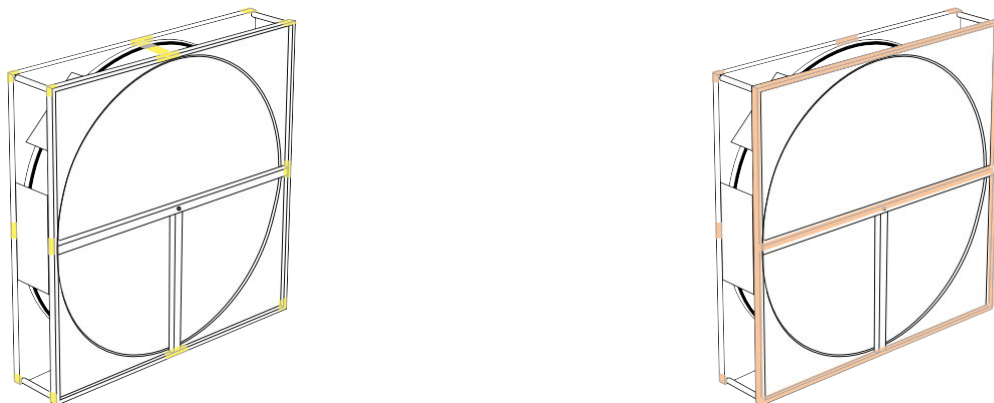

Picture 4. Support positions, vertical installation (left) and horizontal installation (right).

Ensure the casing is installed perpendicular to the AHU's horizontal bottom surface to prevent warping which may cause interference with the wheel.

Special attention is required for the structure on the AHU side where the cross beam is attached horizontally when using a casing with a vertical plane of intersection/ side by side flow. The AHU side structure needs to support a significant portion of the force as shown in Picture 3. There should also be sufficient support beneath the vertical beam as this supports the weight of the wheel.

For horizontal rotors, provide support for the frame and the cross beam. Pay special attention to the focal point of the rotor as this point needs to support the weight of the wheel. Confirm that the rotor is designed and manufactured for horizontal installation.

Rotor may only be installed either in a vertical or a horizontal position according to design, not tilted unless approved by Heatex

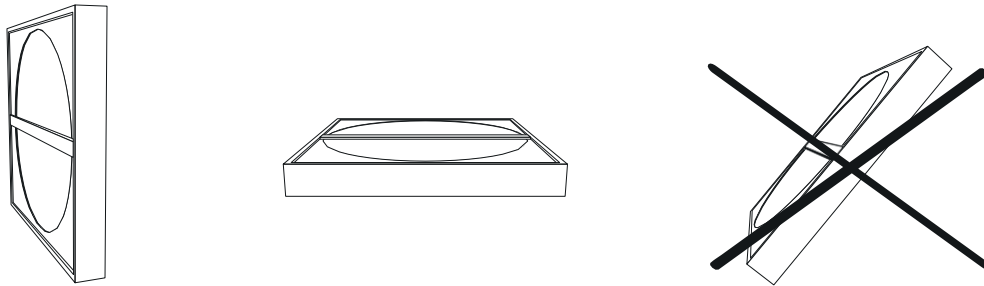

Picture 5. Rotor positions.

 In case of a horizontal rotor, support is needed for the frame and center beam.

- Avoid angular flow, as it can impact the rotation and drive of the wheel. Heatex AB recommends the air-flow to be perpendicular to the rotor.
- The rotor is designed for counter flow only. Co-current flow decreases efficiency and reduce the rotors self-cleaning ability.
- Prior to initial operation, please ensure there are no obstructions hindering the rotor's movement. The rotor should rotate smoothly.

 Placing the unit on an uneven surface may warp the rotor.

Drive motor if delivered with controller is pre-wired and 230V should just be wired to the controller. Constant speed motors are without wiring. It is important that all electrical work is carried out by qualified staff. Please see enclosed documentation and/or wiring Picture 6.

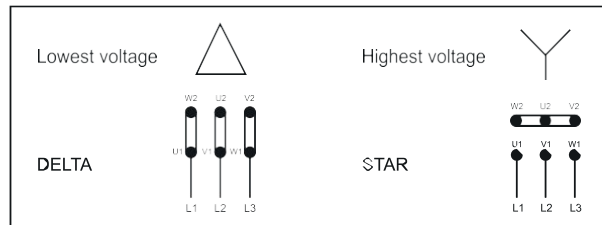

Picture 6. Wiring diagram constant drive Δ/Y 220/380V.

- The motor and the controller should be easily accessible for service and maintenance.
- If the unit is delivered with a variable speed drive, read the corresponding controller documentation.
- Pressure difference and pressure drop should under no circumstances exceed the limits. Please refer to Application Limits for further information.
- The customer needs to make sure that the fans are placed in a way that an evenly distributed force is assured.

5 PRE-START ADJUSTMENTS AND INSPECTIONS

Check basic adjustments before initial startup. If adjustments are required, please refer to part 6 Maintenance.

- Check brush sealings.
- The special sealing does not need any adjustments.
- Check belt tension, belt should not slide over wheel.
- For large casings ($\varnothing > 1500$ mm) ensure wheel is parallel to casing. Adjust the turn buckles on either side to ensure the rotor is straight. If necessary, the wheel can be adjusted with a predetermined tilt against the air flows.

6 MAINTENANCE

6.1 Matrix

To ensure proper function and performance, the face of the rotor must be inspected regularly for dust and dirt. In most cases, the rotor is self-cleaning due to the counter flow and rotation of the wheel, which makes manual cleaning unnecessary. If the self-cleaning is insufficient dirt and/or dust can appear in the matrix.

Depending on the degree of soiling it is recommended to use following cleaning methods:

1. A vacuum cleaner is to be used for a small amount of easily removable dirt.
2. For heavier dirt it is also possible to use compressed air but with caution.
3. Firmly attached dirt in the rotor is easiest removed by using hot water and a mild detergent. The mild detergent may be removed with high-pressure water cleaner with the nozzle placed 300 mm from the matrix.
4. If required, Heatex recommends disinfection with the substance known as LIV +45 (isopropanol based substance).

6.2 Adsorption and Enthalpy Wheels

The adsorption material is aluminum coated with silica gel or molecular sieve 3Å coating. There is a small amount of surplus material that might leave the matrix during the first usage. This will NOT affect the hygroscopic properties. The excess powder is harmless and easy to remove using a vacuum cleaner.

The enthalpy wheel properties are obtained by a combination of adsorption material consisting of silica gel coated aluminum and a corrugated aluminum strip. Just as for the adsorption wheel, a small amount of surplus material might leave the matrix during the first usage.

6.3 Power Belt

The power belt must be positioned so that the thinner side of the belt is in constant contact with the inside of the pulley.



The belt should be twisted so the thicker side is in contact with the wheel for better friction.



The power belt is subject to natural stretching which may require shortening of the belt. Tension of the belt must be checked after the first 24-48 hours in operation to secure the rotational function of the wheel.

The belt is made of links that can easily be added or removed without any tools. By just twisting the belt, it is possible to open it and remove links to shorten the belt until correct length and belt tension is obtained. Belt tension should be 1-2% (i.e. belt length 1-2% shorter than travelled length). For power belt remove one link per meter belt to get correct tension.

6.4 Round Belt

When delivered the belt is welded together. If adjustment is needed the belt must be cut, shortened and joined together again with a special joining pin, which is attached to the inside of the casing (see Picture 7). Belt tension should be 3%. The belt may need adjustment during its lift time due to stretching.



Picture 7. Joining pin location.

6.5 Brush Sealings

Tightness between brush sealings and casing must to be checked during inspection. The brush sealings are easily adjusted by unscrewing the screws and moving the brush sealing into the right position.

6.6 Special Seals

- The tightness of the special sealing is adapted at the Heatex factory and is not possible to readjust on site. The new seal design makes it possible for Heatex to deliver a tight seal to every customer despite the conditions.
- Yearly inspections are needed to verify the conditions of the seals.
- If required, replacement seal can be ordered from Heatex.

6.7 Purge Sector

The purge sector can be pre-mounted if a position is specified in the order of the heat exchanger, or it can also be mounted later when preconditions are known. The purge sector can be mounted in four different positions and the position of the purge sector can be changed when it is required. For further information regarding how to mount the Purge Sector refer to Mounting of loose Purge Sector (Separate document). There are three different angle sizes (7°, 10° and 15°) for Purge Sector which depends on the rotational speed of the rotor:

- 12RPM = 7°
- 17RPM = 10°
- 25RPM = 15°

6.8 Control Unit

For further information regarding rotary heat exchangers equipped with control unit, please see corresponding controller instructions.

6.9 Rotor Tilt

For large rotors ($\text{Ø}1501$ - $\text{Ø}2575$) the possibility to tilt the rotor is built in. This is used to compensate for the leaning that occurs during high airflows. The turnbuckles on either side of the rotor are adjusted until the desired tilt is reached. The turnbuckles need to be adjusted in opposite ways. When a turnbuckle is shortened the top part of the rotor leans towards you and the turnbuckle is lengthened the top part leans away. Lock the turnbuckles with the nuts when the rotor is adjusted. Assure acceptable friction when turning the wheel.

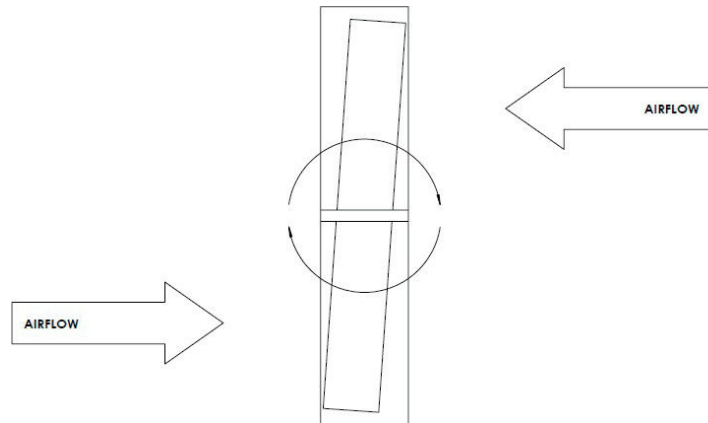

Possibility to compensate wheel deflection caused by airflows.

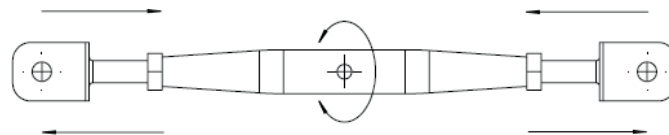

Turn the turnbuckle to adjust the wheel.

6.10 Motor Access

For small to medium sized rotors ($\text{Ø}500$ - $\text{Ø}1500$) the motor is placed upon a motor plate which can be removed by 4 screws, 2 on the front and 2 on the back side of the casing.

For large rotors ($>\text{Ø}1500$) it is possible to remove either the motor plate and motor or the motor alone. The motor is held in place by 4 screws accessed on the back side on the motor plate. The screws for the motor plate are accessed from the external side.

For inspections and minor maintenance issues the motors can be accessed via the inspection hatches if they are present. (Special casing option).

6.11 Application Limits

Recommended temperature limits for rotary heat exchanger Model E are -40°C (-40°F) to +65°C (149°F). It is however important not to exceed the temperature limits on mounted components:

| Component | Min | Max |
|---------------------------------------|---------------|---------------|
| Bearings | -40°C (-40°F) | 110°C (230°F) |
| Yellow belt | -30°C (-22°F) | 66°C (150°F) |
| Power belt | -40°C (-40°F) | 110°C (230°F) |
| Constant motor | -10°C (14°F) | 40°C (104°F) |
| Varimax step motor and control | -30°C (-22°F) | 45°C (113°F) |
| OJ step motor and control with modbus | -40°C (-40°F) | 40°C (104°F) |
| Standard seals | -25°C (-13°F) | 90°C (190°F) |
| Special seals | -25°C (-13°F) | 90°C (190°F) |



NOTE! The temperature inside the casing is approximately the mean temperature of supply and exhaust air temperatures.

Maximum and recommended pressure drop as well as differential pressure for rotary heat exchanger:

- Pressure drop max 300 Pa (1.2" WC) up to outer diameter 1600 mm (62.99") and pressure drop max 250 Pa (1" WC) up to outer diameter 2575 mm (101.38"), even during start up and maintenance.
- Recommended pressure drop 100-200 Pa (0.4-0.8" WC) (normal operation).
- Differential pressure max 600 Pa (2.4" WC).

6.12 Troubleshooting

If the rotary heat exchanger does not rotate properly, please see the following steps to solve/locate the problem.

1. If the motor runs properly, please jump to step 5.
2. If there is a controller installed, please check controller technical specifications, chapter trouble shooting.
3. If there is a constant drive installed: Please check that the drive is correctly connected. Note that all electrical maintenance and installation must be performed by qualified personal.
4. The position of the pulley should be placed as near the center of the rotor as possible.
5. Disconnect the belt. Is the motor running correctly?
6. If the belt is sliding, please tighten the belt according to maintenance instruction.
7. Rotate the wheel by hand in the indicated direction (belt disconnected from the motor). Is it possible to smoothly rotate the wheel or does the wheel interact with the casing? If there is excessive friction between the wheel and the casing (making it hard to rotate), please locate the position.
8. Make sure the connected ducts do not press on the casing making it squeeze against the wheel. Make sure the diagonal measures of the casing side where the motor is positioned are equal.
9. If the rotor with special seals doesn't rotate, please follow these steps. First, before turning on the drive system, rotate the wheel manually a couple of times in the same direction that it is supposed to rotate. The brushes of the seal need to adapt to the rotating direction. Then, turn on the drive and make sure that the direction of rotation is the same as when the wheel was rotated manually.

6.13 Conditions to Fulfill the Hygiene Certification Requirements

- Purge sector is required in order to make sure that less carry-over than 3% is reached.
- The AHU needs to be designed with hatches or openings towards all 4 open sides of the rotary heat exchanger. The heat exchanger itself has all 4 sides open according to the picture 8.
- All surfaces inside and outside of the rotor casing, especially the bottom surface and around the motor should be reachable for maintenance, cleaning and disinfection. Meaning that the openings or hatches mentioned in the item above need to be of sufficient size to fulfilling the cleaning and disinfection requirements.
- The AHU needs to be designed in such a way that the rotary heat exchanger is possible to slide out for cleaning and disinfection.
- Cleaning and disinfection of the heat exchanger should be done in accordance with Heatex cleaning and disinfection instructions with the cleaning and disinfection substances prescribed by Heatex (see Maintenance chapter).
- When condensation is present, the AHU installer needs to make sure that condensation trays are installed beneath the heat exchanger. These trays need regular inspection, cleaning and disinfection.
- The trays should be designed and installed with sufficient drainage in accordance with the hygiene standard VDI 6022, chapter 4.3.16.
- The heat exchangers are not certified for installation in exhaust classes ETA 3 and ETA 4 according to EN 13779 (09/2007).

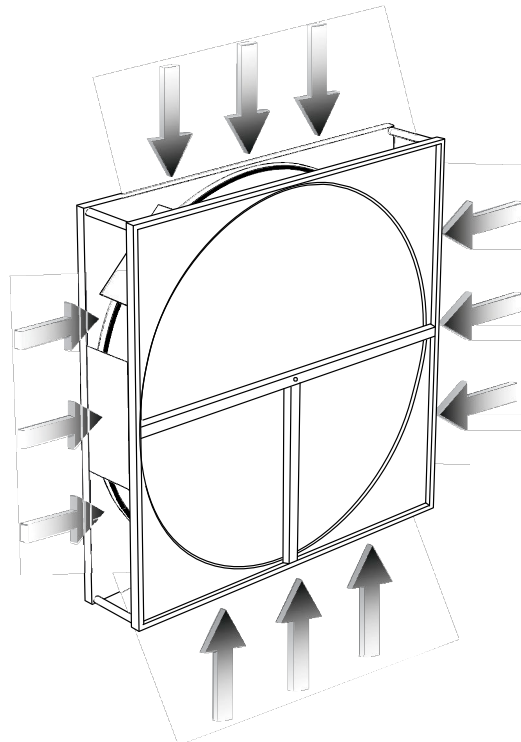

Picture 8. All 4 sides are open on the heat exchanger. The AHU designer and installer need to have openings or hatches on all of these 4 sides in the AHU for easy access during maintenance, cleaning and disinfection of the heat exchanger.

7 BELT REPLACEMENT

7.1 Belt replacement step 1

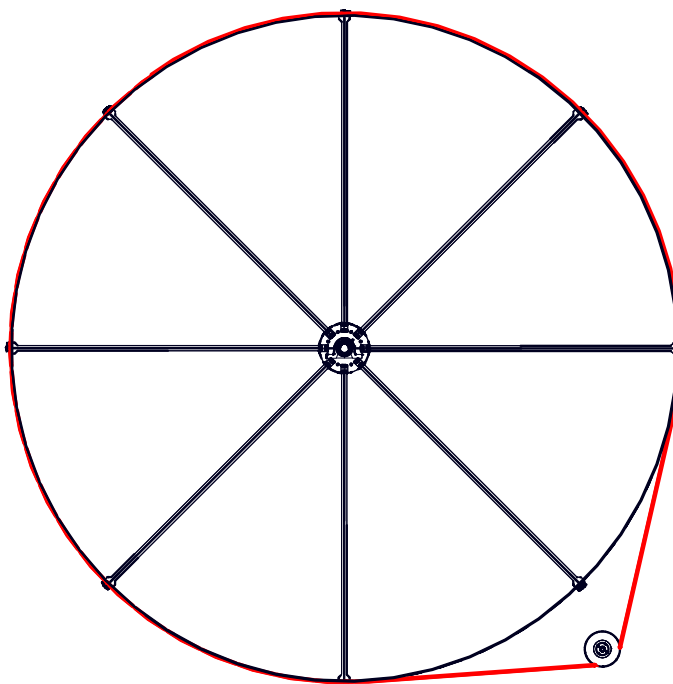

1. Stretch belt over the wheel and pulley to determine appropriate belt length.
2. Mark where the belt ends meet.
3. Split the belt at the mark.
4. To achieve desired tension of belt, a few links must be removed from the belt.
5. Calculate the circumference of wheel, i.e $\varnothing * \pi$.
6. Remove one link from the belt per meter of the wheel circumference.

Example:

Wheel diameter: 3800mm. $\varnothing * \pi = 3800 * \pi = 11938mm = 12m$.

Wheel circumference is 12m, so 12 links is to be removed from belt to achieve final belt length.

Always round up to full meter (ex: 8200mm → 9m).

Refer to [video](#) for detailed instructions of how to assemble and split the belt links.

7.2 Belt replacement step 2

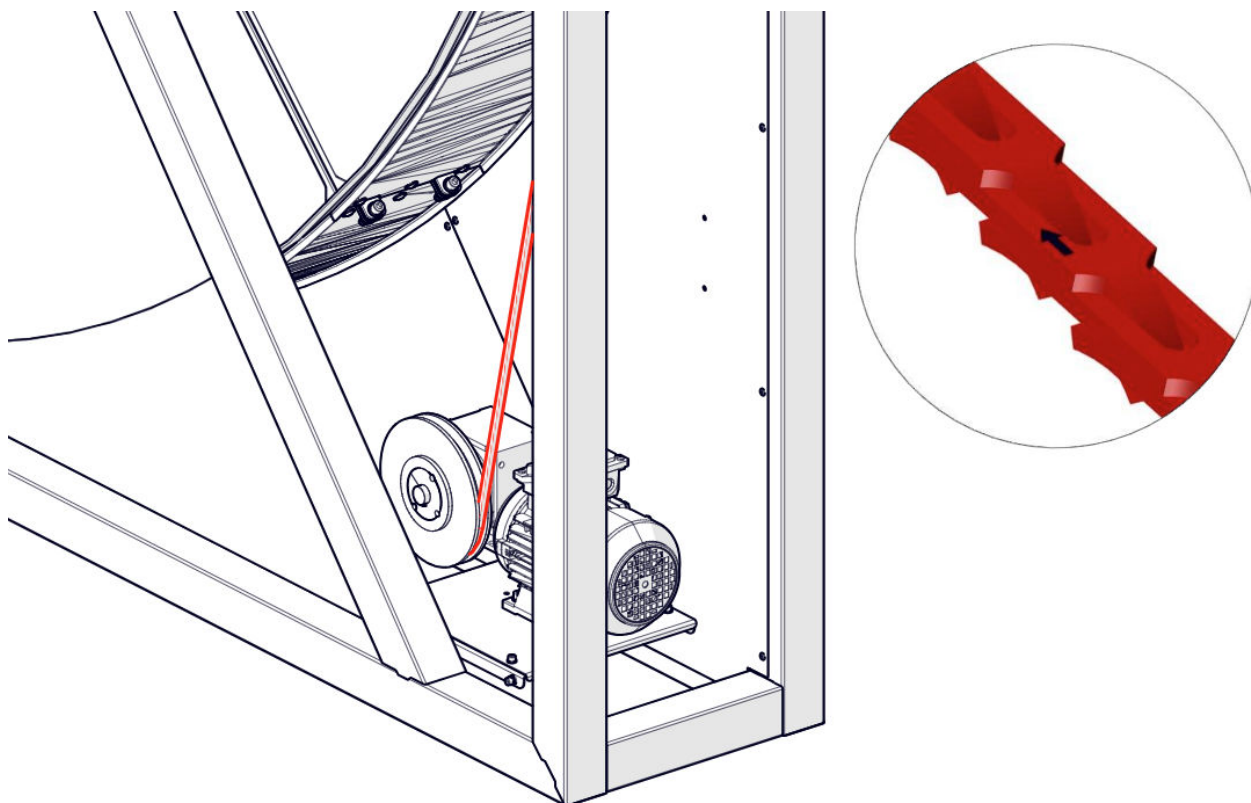

1. Mount belt on pulley and wheel.
2. Flat side of the belt is to face the wheel.
3. Opposite side of the belt with knobs is to face the pulley, so the belt must be twisted 180 degrees on the length between wheel and pulley.
4. Make sure that the belt does not run over the brush guard.
5. Take note of arrow on the belt. It is to be visible when mounted on the wheel and arrow is to indicate direction of which the wheel will rotate.

Note: 1x cover plate hidden in image.

Refer to [video](#) for detailed instructions of how to assemble and split the belt links, as well as how to mount the belt.

8 MOTOR REPLACEMENT

8.1 Motor replacement step 1

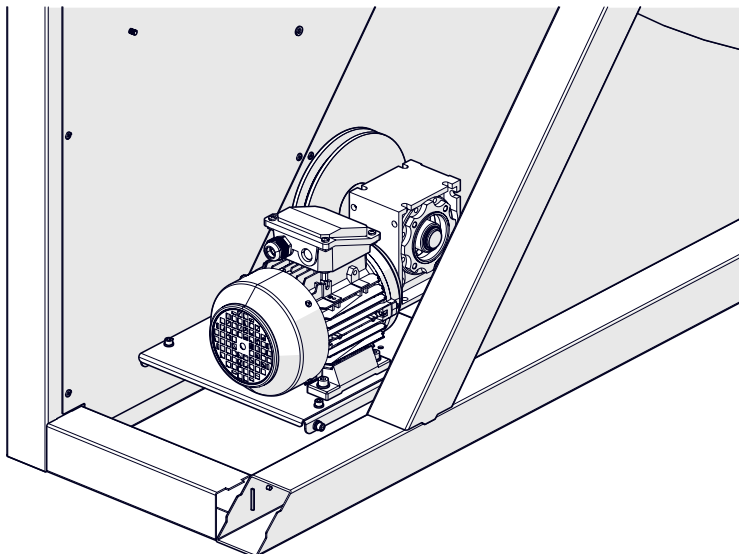

Note: 1x cover plate and 1x casing profile hidden in image.

8.2 Motor replacement step 2

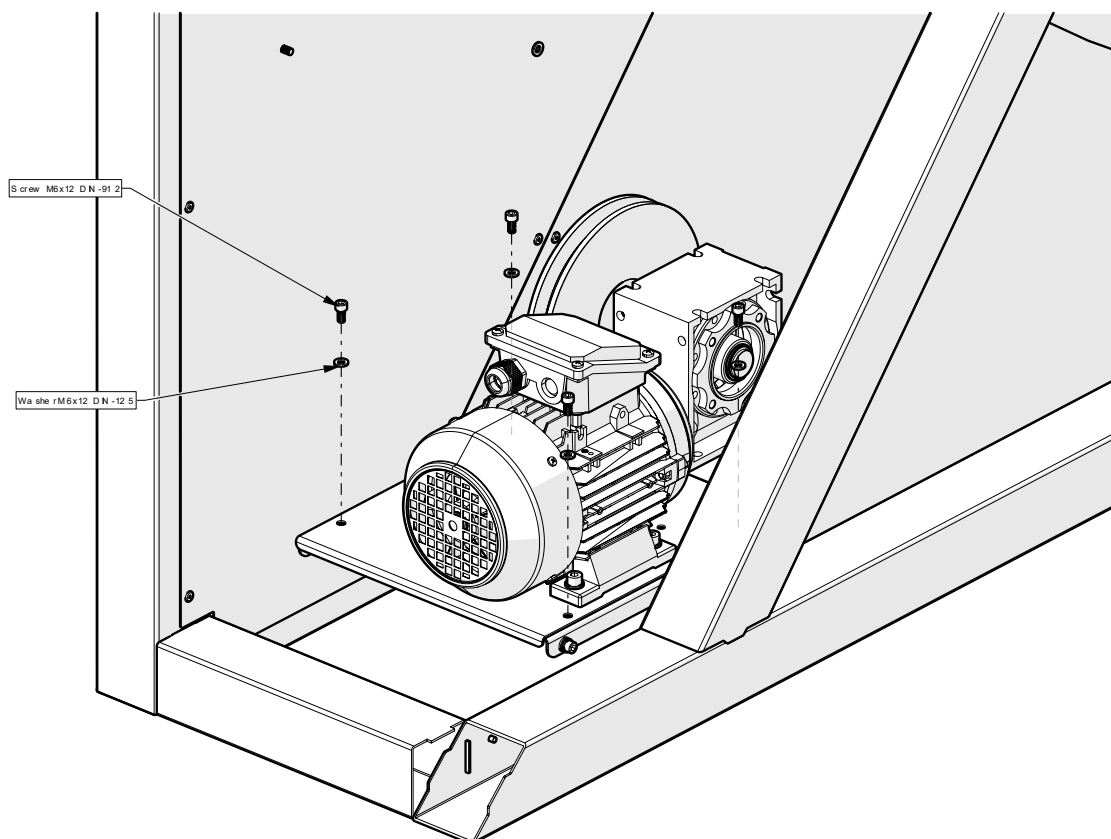

Remove screws and washers to disconnect motor plate from brackets.
Save fasteners for later reassembly.

8.3 Motor replacement step 3

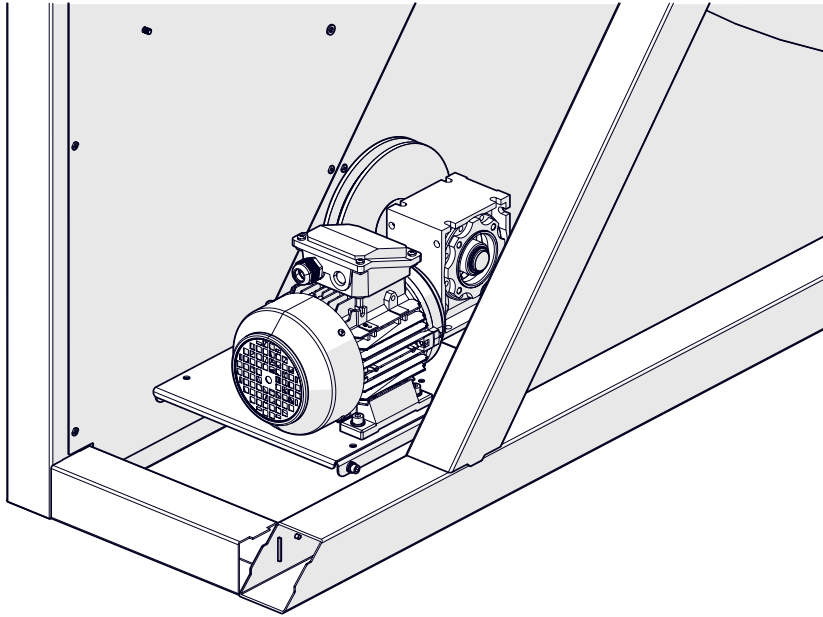

Fasteners removed.

8.4 Motor replacement step 4

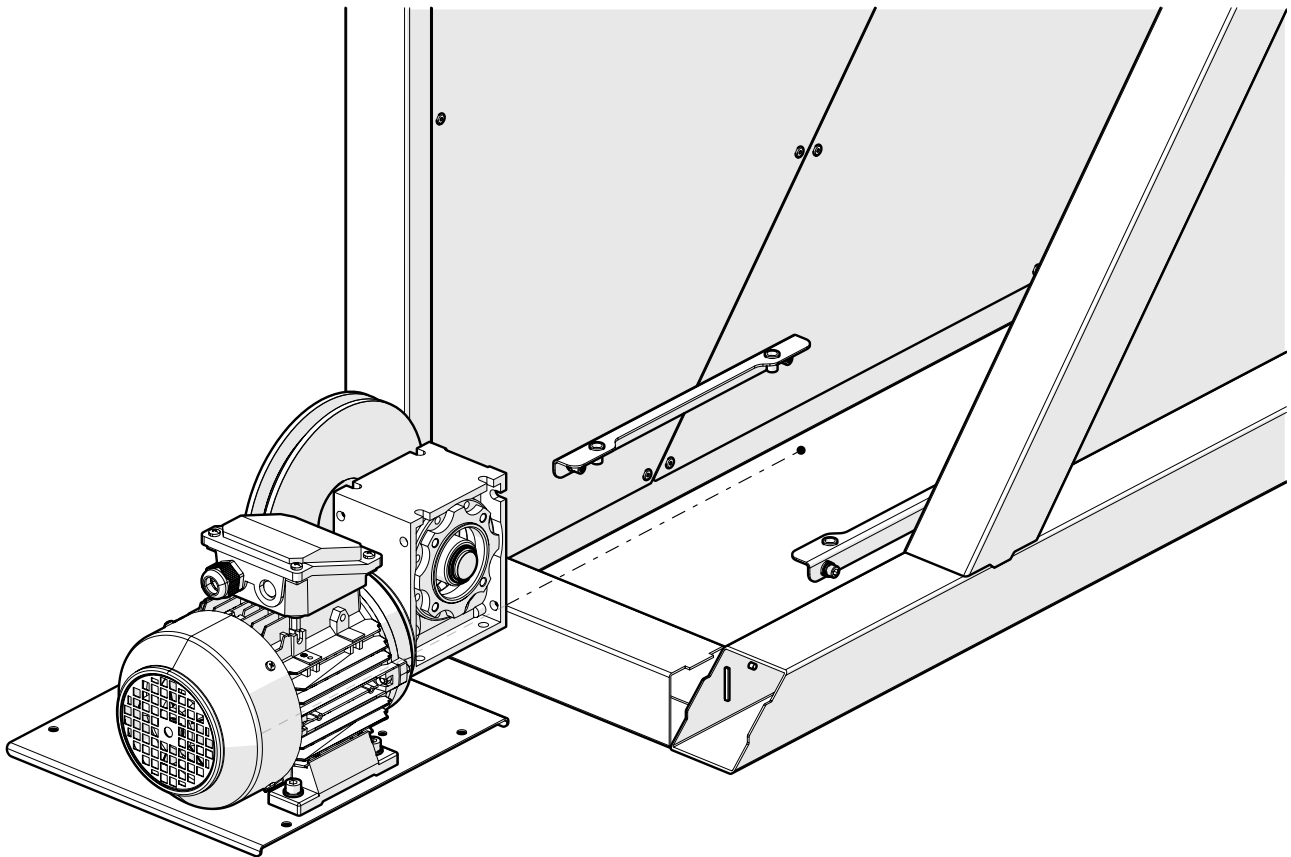

Remove motor plate with motor attached.

Motor can then be disconnected from motor plate by loosening screws.

Take note of cables connected to the motor.

8.5 Motor replacement step 5

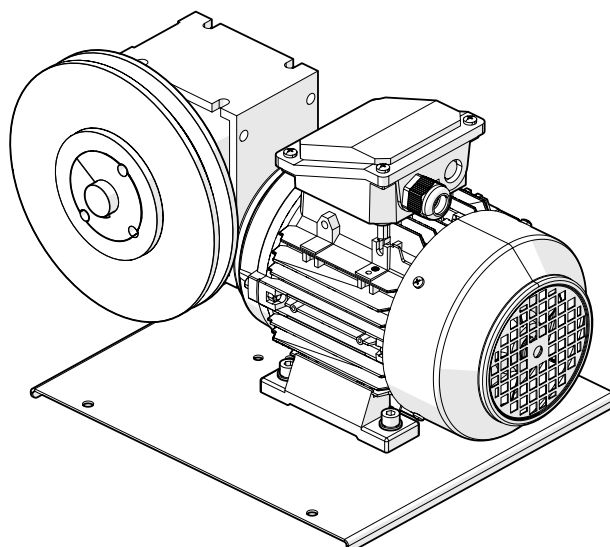

8.6 Motor replacement step 6

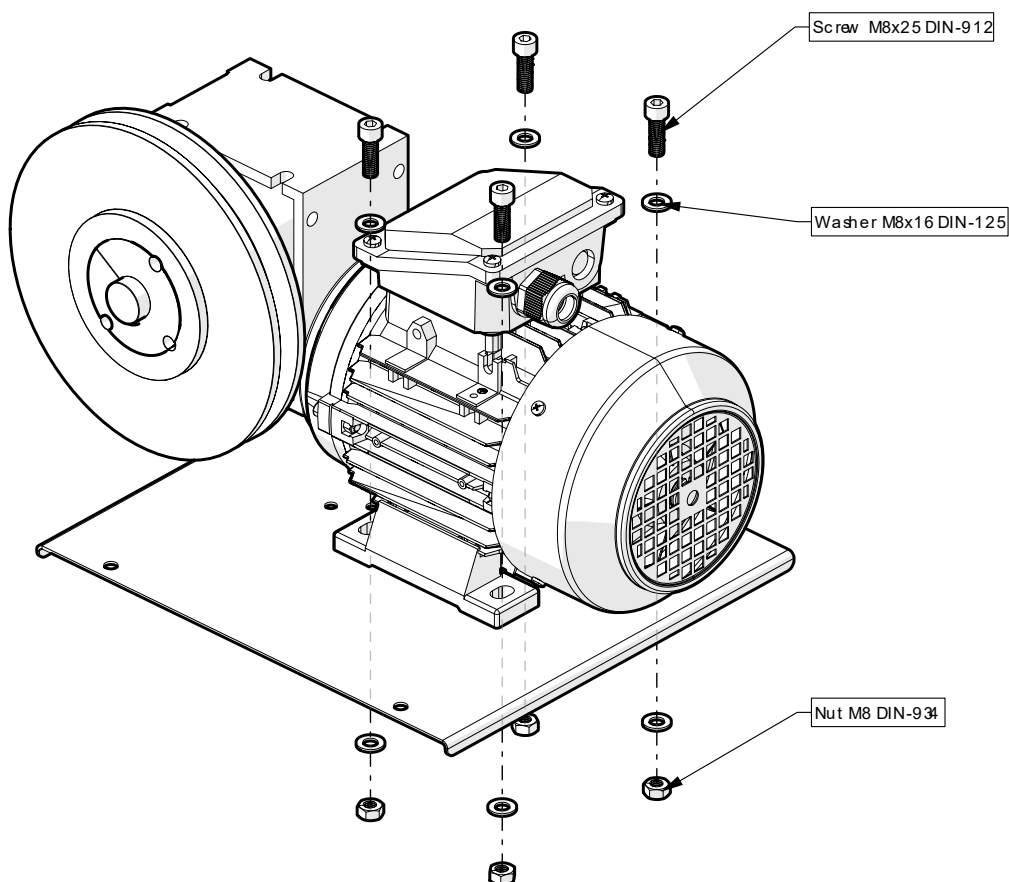

Remove fasteners to disconnect motor from motor plate.
Save fasteners for later reassembly.

8.7 Motor replacement step 7

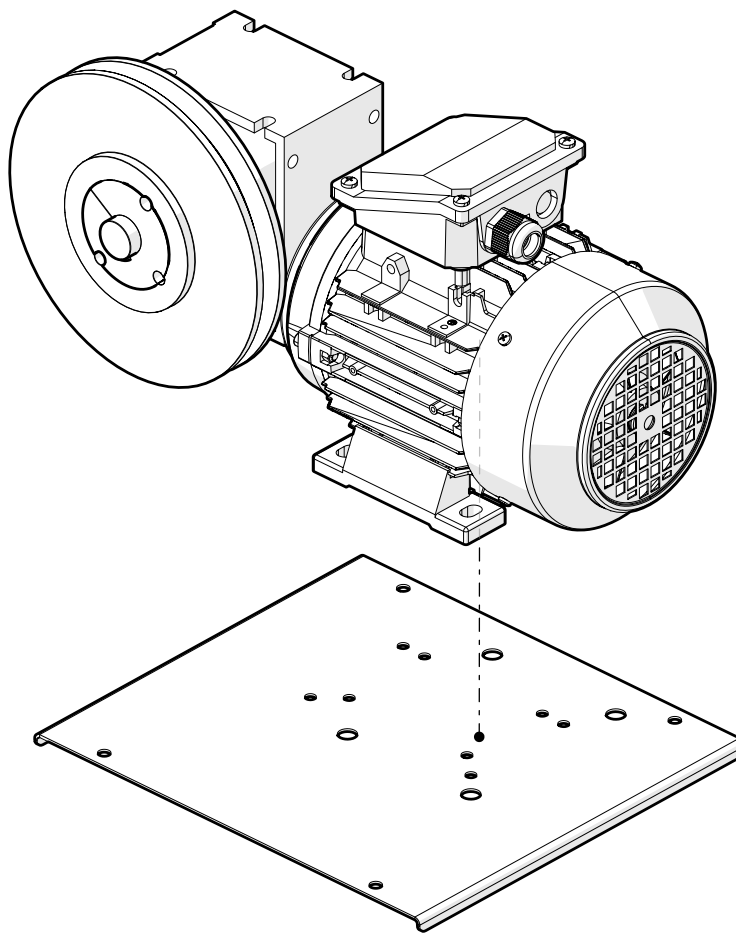

Motor can now be removed from motor plate and replaced.
Follow inverse of steps 2.1-2.7 to reassemble the motor.

9 CONTROLLER REPLACEMENT

9.1 Controller replacement step 1

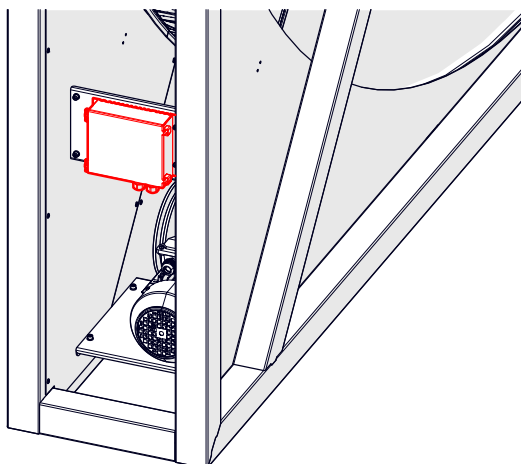

Note: Control unit is located in the top corner on the motor side of the rotor for model E heat exchangers. For model ES heat exchanger, the control unit is located as in image above.

9.2 Controller replacement step 2

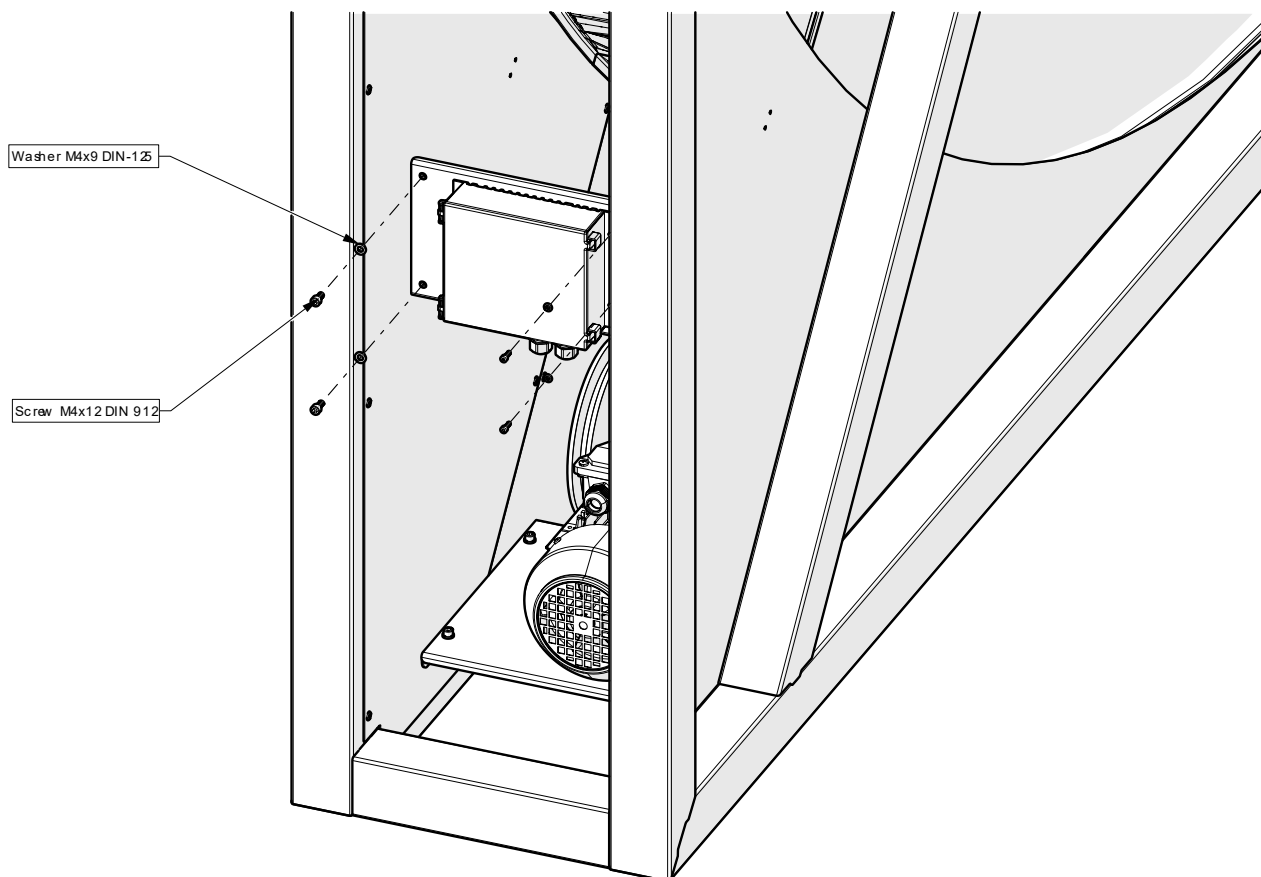

Remove screws and washer to disconnect control unit holder plate from brackets. Keep fasteners for later reassembly.

9.3 Controller replacement step 3

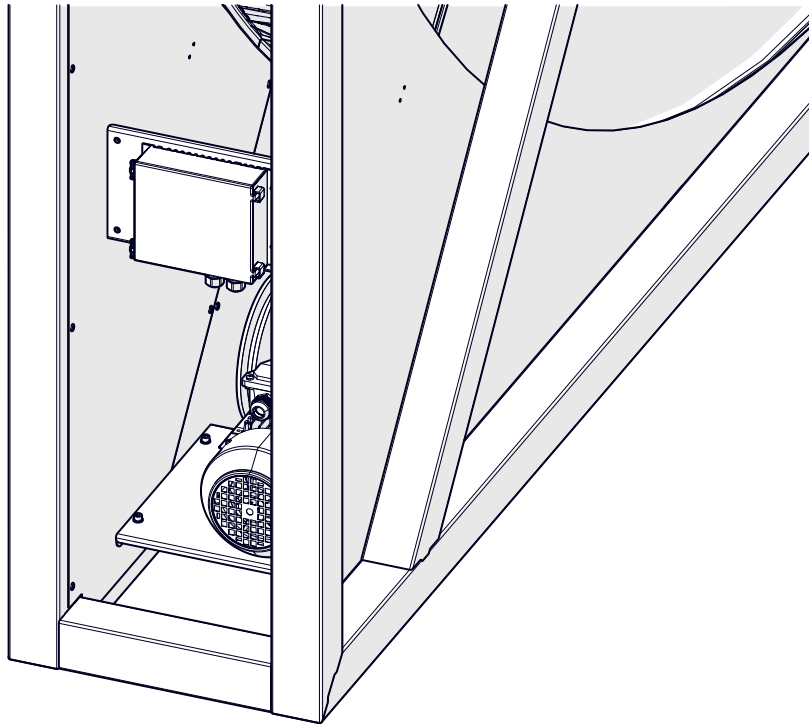

Fasteners removed.

9.4 Controller replacement step 4

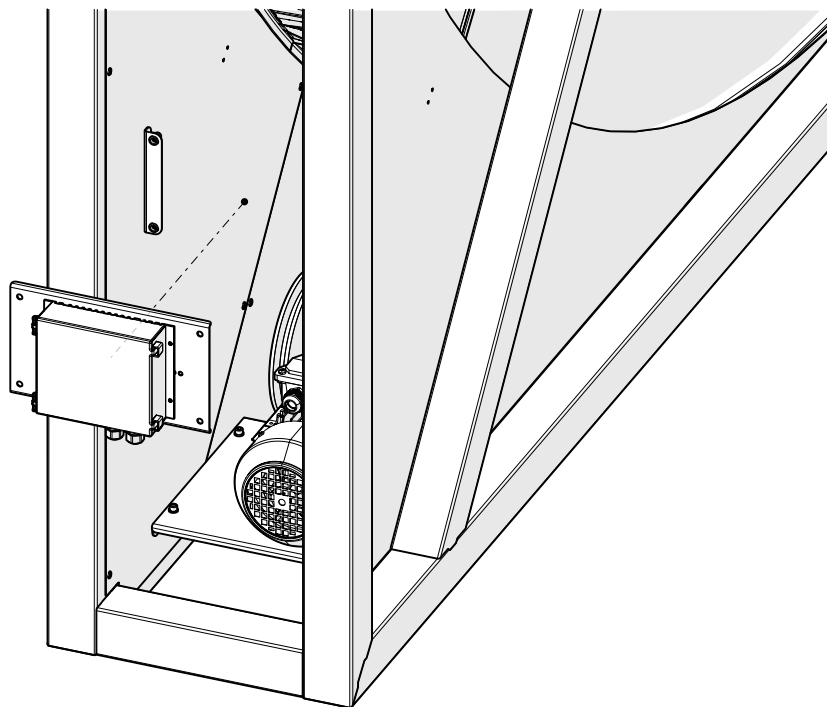

Remove control unit holder plate with control unit attached.
Control unit can then be disconnected from the plate by loosening screws.
Take note of cables connected to the control unit.

9.5 Controller replacement step 5

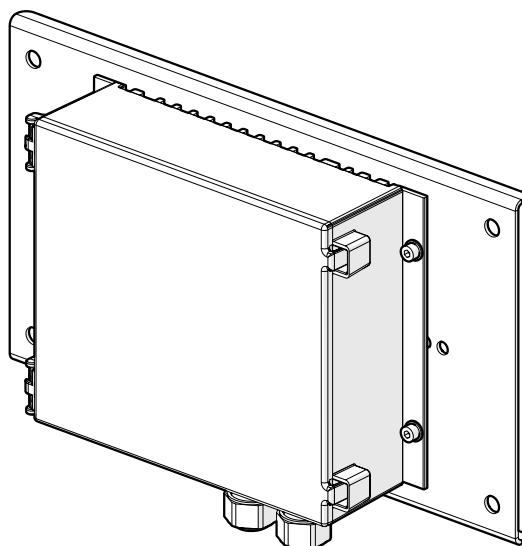

9.6 Controller replacement step 6

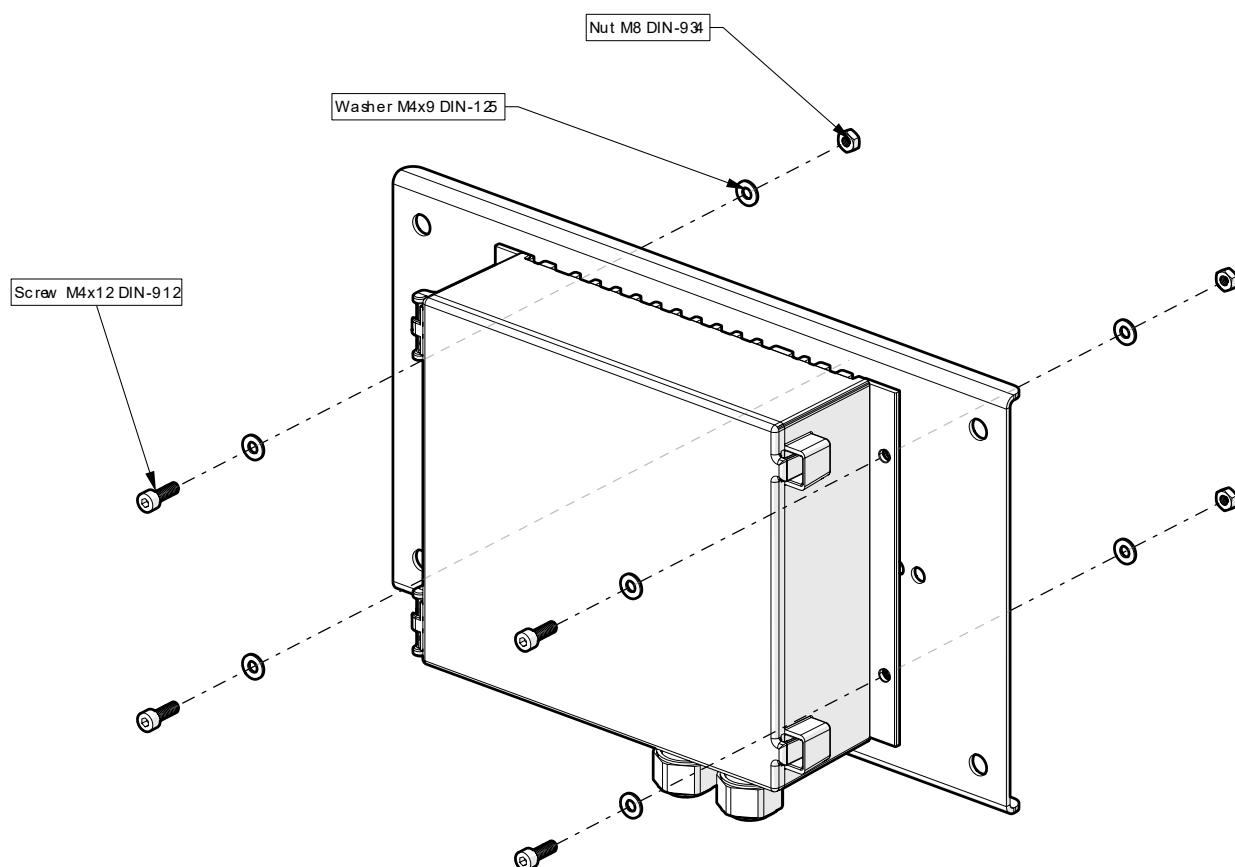

Remove fasteners to disconnect control unit from control unit holder plate.
Save fasteners for later reassembly.

9.7 Controller replacement step 7

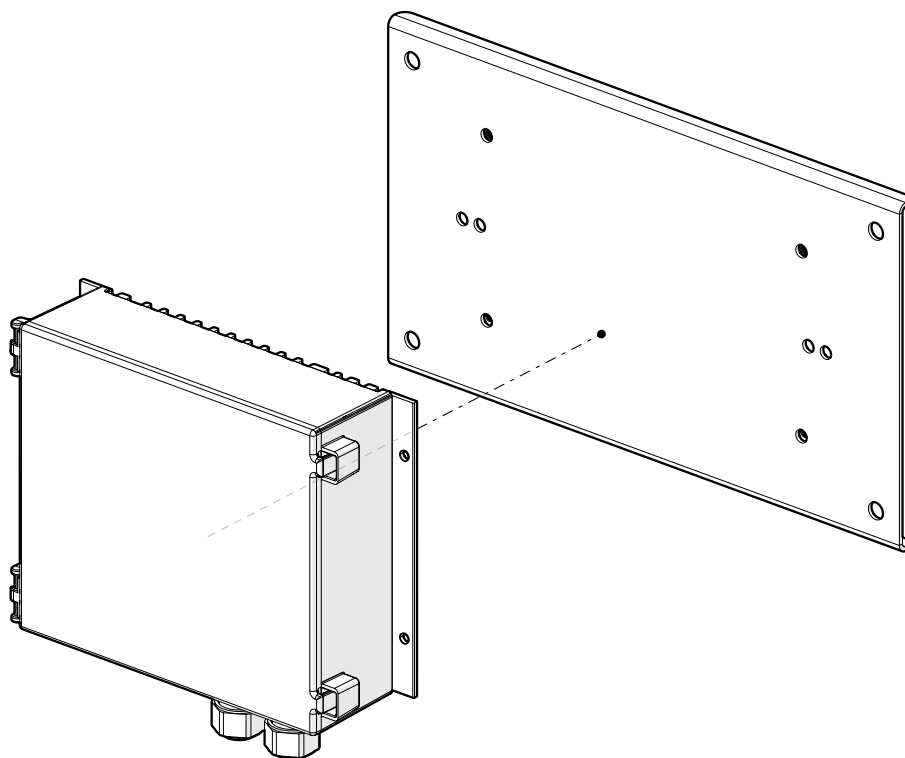

Control unit can now be removed from control unit holder plate and replaced.
Follow inverse of steps 3.1-3.7 to reassemble the control unit.

10 APPENDIX

| IBC Error Code | IBC Error Code Description | Possible Cause of IBC Error Code | Check the Following (IBC) | Do This (IBC) |
|-------------------|---|----------------------------------|--|---|
| Rotation monitor | Control unit tripped due to rotation sensor | Broken belt | Check if the belt is connected and without any significant damage | Replace belt -> https://www.heatex.com/resources/installation-maintenance-videos/ |
| | | Belt slipping | Check the belt if it's not loose. If belt is slipping in pulley or on rotor = it's loose. | Shorten the belt -> https://www.heatex.com/resources/installation-maintenance-videos/ |
| | | Stuck rotor | Check if the rotor is not leaning. Measure distance between rotor and casing on 4 spots, on both sides, each 90° with fans on. All 4 measurements should be equal. | Please contact Heatex with problem description and measured dimensions, pressure drop and air flow values... claim@heatex.com - probably shaft replacement is needed. |
| | | Motor damage | Measure power supply | Adjust power supply |
| | | | Measure noise level and compare with limits in installation and maintenance manual | Motor has to be replaced if noise is off limits. Please contact: claim@heatex.com |
| | | | Measure motor temperature and compare with limits in installation and maintenance manual | Motor has to be replaced if temperature is off limits. Please contact: claim@heatex.com |
| Motor temperature | The thermal contact in the motor has tripped due to motor winding overheating | The rotor is heavy to run | Check if the rotor is not leaning. Measure distance between rotor and casing on 4 spots, on both sides, each 90° with fans on. All 4 measurements should be equal. | If rotor is leaning please contact Heatex with problem description and measured dimensions, pressure drop and air flow values... claim@heatex.com - probably shaft replacement is needed. |
| | | The gear is jammed, no oil | Check motor gear | Turn with motor shaft. |
| | | Motor gear is broken | | |
| Overvoltage | Overvoltage | Overvoltage | Power supply does not exceed 276 V for more than 4-5 seconds, after which the control unit trips. Check the power supply. | Adjust power supply |
| Undervoltage | Undervoltage | Undervoltage | Power supply is below 195 V for more than 4-5 seconds, after which the control unit trips. Check the power supply. | Adjust power supply |
| Overcurrent | Short circuit | The rotor is heavy to run | Measure motor resistance, it should be identical on all phases. | Motor has to be replaced if resistance is not identical on all phases. Please contact: claim@heatex.com |

| IBC Error Code | IBC Error Code Description | Possible Cause of IBC Error Code | Check the Following (IBC) | Do This (IBC) |
|-------------------|---|--|---|---|
| | | The gear is jammed, no oil | Check cable if it's not between cove and terminal box frame. | Motor has to be replaced |
| | | Motor/gear is broken, e.g. bearing fault | Measure resistance between phase and earth. It should be infinite. | Motor has to be replaced if resistance is not identical on all phases. Please contact: claim@heatex.com |
| | | The control unit is broken | Reset control unit. | Please contact: claim@heatex.com |
| No LED lit | No Led Lit | Different power supply | Measure power supply on terminals L and N, should be 230 V. | Adjust power supply |
| The wheel rotates | The wheel rotates despite a 0% input signal from the control unit | Voltage | Measure the voltage across terminals 2-3. It should be below 0.07 V for the control unit to switch off. | Please check IBC manual https://ibccontrol.com/wp-content/uploads/2023/12/Troubleshooting-English.pdf |
| | | | Check that High Speed and Low Speed DIP switches are set to OFF. | Please check DIP swiches settings: https://ibccontrol.com/en/manuals/ |

| OJ Error Code | OJ Error Code Description | Possible Cause of OJ Error Code | Check the Following (OJ) | Do This (OJ) |
|---------------|---|---------------------------------|--|---|
| E01 | Alarm from rotor guard | High pressure drop | Check pressure drop values and compare with Heatex limits. | Re-adjust AHU according to Heatex limits. |
| | | Missing fixation | Check Heatex installation and maintenance manual how casing has to be fixed and compare with situation on site. | Implement fixation according to Heatex installation and maintenance manual. |
| | | Broken shaft | Check is the rotor is not leaning. Measure distance between rotor and casing on 4 spots, on both sides, each 90° with fans on. All 4 measurements should be equal. | If rotor is leaning please contact Heatex with problem description and measured dimensions, pressure drop and air flow values... claim@heatex.com - probably shaft replacement is needed. |
| | | Loose belt | Check the belt if it's not loose. If belt is slipping in pulley or on rotor = it's loose. | Shorten the belt according to manual https://www.heatex.com/resources/installation-maintenance-videos/ |
| | | Internal error of control unit. | Control unit set up. | Reset control unit according to manual: https://ojelectronics.com/hvac/products/drhx-analog-control/ |
| E02 | Excessive supply voltage | | Measure voltage on supply of the control unit. Too high = wrong supply voltage. | Adjust supply voltage |
| | | | Internal error of control unit. | Open link to manual and proceed according to manual https://ojelectronics.com/hvac/products/drhx-analog-control/ |
| E03 | Insufficient supply voltage | | Measure voltage on supply of the control unit. Too low = wrong supply voltage - customer needs to handle with AHU manufacturer. | Adjust supply voltage |
| | | | Internal error of control unit. | Open link to manual and proceed according to manual https://ojelectronics.com/hvac/products/drhx-analog-control/ |
| E04 | Power to the motor increased at a critical level, e.g. short-circuiting cable, connector or motor | | Please check all cables - cable from control unit to the motor if it's without damage. | If cable is damaged, needs to be replaced. Please contact: claim@heatex.com |

| OJ Error Code | OJ Error Code Description | Possible Cause of OJ Error Code | Check the Following (OJ) | Do This (OJ) |
|---------------|--|-----------------------------------|--|---|
| | | | Internal error of control unit. | Open link to manual and proceed according to manual https://ojelectronics.com/hvac/products/dr-hx-analog-control/ |
| E05 | Excessive temperature inside the OJ DRHX (> 95°C) | Wrong input voltage | Input voltage | Adjust supply voltage according to manual https://ojelectronics.com/hvac/products/drhx-analog-control/ |
| | | Component failure in control unit | | Internal defect of control unit, needs to be replaced. Please contact: claim@heatex.com |
| E06 | Blocked motor | Leaning rotor | Check is the rotor is not leaning. Measure distance between rotor and casing on 4 spots, on both sides, each 90° with fans on. All 4 measurements should be equal. | Check pressure drop and adjust according to Heatex limits that can be found in Heatex Select. |
| | | Broken/Grinded shaft | Check is the rotor is not leaning. Measure distance between rotor and casing on 4 spots, on both sides, each 90° with fans on. All 4 measurements should be equal. | Take the belt out of the pulley nad turn rotor by hand - without any load. |
| | | Wrong settings | Check dip switches | Set dip switches according to manual https://ojelectronics.com/hvac/products/drhx-analog-control/ |
| | | Missing signal | Check if there is 0-10V signal from AHU to the control unit | Check if AHU setting is correct. Check if cable is not damaged. |
| | | Stuck bearings | Take the belt out of the pulley nad turn rotor by hand - without any load. | Internal hardware issue. Please contact: claim@heatex.com |
| E07 | No valid RS-485 interface communication >10 sec | Electronics error | | Internal hardware issue. Please contact: claim@heatex.com |
| 1. E08 | 1. Phase fault on stepper motor power supply (U, V, W) | 1. Wrong connection | Check control unit connection | Internal hardware issue. Please contact: claim@heatex.com |

| OJ Error Code | OJ Error Code Description | Possible Cause of OJ Error Code | Check the Following (OJ) | Do This (OJ) |
|---------------|----------------------------|---------------------------------|--------------------------|--|
| | | | Check motor connection | Internal hardware issue. Please contact: claim@heatex.com |
| 1. E09 | 1. Internal hardware error | 1. Electronics error | | Internal hardware issue. Please contact: claim@heatex.com |