

HEATEX

PLATE HEAT EXCHANGERS



TECHNICAL INFORMATION

ADDRESS AND CONTACT DATA

Heatex AB
Hyllie Boulevard 34
213 75 MALMÖ
Sweden
Telephone: +46 410 710 500
info@heatex.com
www.heatex.com

DISCLAIMER

Information in this document (including URL references and information from other external sources referred herein) is subject to change without notice. Owing to continued product development, Heatex reserves the right to introduce alterations in both design and prices without prior notice.

THIS DOCUMENT IS PROVIDED "AS IS" WITH NO EXPRESSED OR IMPLIED WARRANTIES WHATSOEVER, INCLUDING ANY WARRANTY OF MERCHANTABILITY, NON-INFRINGEMENT, FITNESS FOR ANY PARTICULAR PURPOSE, OR OTHERWISE ANY WARRANTY ARISING OUT OF ANY PROPOSAL, SPECIFICATION OR SAMPLE. ALL LIABILITY, INCLUDING LIABILITY FOR INFRINGEMENT OF ANY PROPRIETARY RIGHTS, RELATING TO USE OF INFORMATION CONTAINED OR REFERENCED IN THIS DOCUMENT IS HEREBY EXPRESSLY DISCLAIMED.

COPYRIGHT NOTICE

All information and content included (whether directly or by reference) in this document, such as text, graphics and images, is the property of Heatex AB, its subsidiaries, affiliates, licensors and/or joint venture partners. All rights are reserved.

No licenses, express, implied or otherwise to any intellectual property rights in this document are granted by Heatex AB.

This disclaimer and copyright notice is subject to and governed by Swedish law.

Copyright © 2026

Heatex AB

CONTENT

1.	HEATEX INTRODUCTION	5
2.	HEAT EXCHANGER DESIGN	5
2.1	Product Selection with Heatex Select	5
2.2	Pressure Differences	6
2.3	Temperatures	7
2.3.1	High temperatures	7
2.3.2	Low temperatures	7
2.3.3	Condensation	7
2.3.4	Freezing	8
2.4	Leakage	8
2.4.1	Air tightness	8
2.4.2	Water tightness	9
2.4.3	IP rating	9
2.5	Media Compability	10
2.6	Orientation	12
2.7	Configuration	13
2.7.1	Two Steps	14
2.8	Sound Dampening	15
2.9	Hygiene	15
2.10	Installation & Handling	16
2.10.1	Transportation	16
2.10.2	Handling	16
2.10.3	Installation	16
2.10.4	Disposal	16
2.11	Cleaning	17
2.11.1	Disinfection	18
3.	CROSS FLOW HEAT EXCHANGERS	19
3.1	Product Code Explanation	19
3.2	Model H2	22
3.3	Model H	25
3.4	Model P	27
3.5	Model Z	29
3.6	Model Z2	31
4.	COUNTER FLOW HEAT EXCHANGERS	32
4.1	Product Code Explanation	32
4.2	Model M	33

5.	OPTIONS	34
5.1	Components	34
5.1.1	Plate material	34
5.1.2	End plates & corner profiles	34
5.1.3	Sealing	35
5.1.4	Corrosion Resistance Tests	36
5.2	Bypass & Dampers	36
5.3	Damper Product Code	37
6.	ADDITIONAL OPTIONS	38
6.1	Further protection and tests	38
6.1.1	AquaSeal	38
6.1.2	Lacquered plate edges	38
6.1.3	Corrosion protected framework	38
6.1.4	Individual air tightness test + report	38
6.1.5	Individual water tightness test + report	38
6.1.6	ATEX test	38
7.	TYPICAL APPLICATION CONFIGURATIONS	39
8.	DEFINITIONS & FUNDAMENTALS	40
8.1	Terms	40
8.2	Pressure Drop and Differential Pressure	41
8.3	Influence of Pressure Differential on Pressure Drop	43

1. HEATEX INTRODUCTION

Heatex specialized in air-to-air heat exchangers and was founded in 1987 in southern Sweden. Since then, the company has grown and has a global presence with production in Europe and China and a global sales force. The product portfolio covers recuperators (cross and counter flow) and regenerative (wheel/rotor) heat exchangers primarily with aluminum (or coated versions) heat transfer surfaces.

Our products follow the most relevant standards, and our selection software is certified according to Eurovent and AHRI certification programs for air-to-air heat exchangers. This includes performance tests at an independent lab. Read more at heatex.com.

2. HEAT EXCHANGER DESIGN

2.1 Product Selection with Heatex Select

Product selection and performance calculation are made in our selection software Heatex Select, which is always available and up to date at heatex.com.

All heat transfer and pressure drop calculations are done with the actual heat exchanger geometry and based on sources such as VDI Wärmesatlas and the International Hand Book of Heat Exchanger Design. The calculations are following the European norm EN 308 and its subdocuments.

For accurate calculations the parameters in table below should be known.

Supply air:
<ul style="list-style-type: none"> • Airflow (either at standard air conditions that is 1013,25 hPa (406.78" WC) and 20°C (68°F) or else the temperature at which the airflow is given must be stated). • Air temperature • Relative humidity of the air (Heatex Select includes a wet bulb, abs. humidity to rel. humidity converter)
Exhaust air:
<ul style="list-style-type: none"> • Airflow (either at standard air conditions that is 1013,25 hPa (406.78" WC) and 20°C (68°F) or else the temperature at which the airflow is given must be stated). • Air temperature • Relative humidity of the air (Heatex Select includes a wet bulb, abs. humidity to rel. humidity converter)
Required performance:
<ul style="list-style-type: none"> • Expected efficiency or transferred power • Maximum allowed pressure drop in the heat exchanger. See separate information about the effect of differential pressure on the pressure drop.
Restrictions regarding dimensions:
<ul style="list-style-type: none"> • Since space often is limited, the maximum allowed diagonal distance (or maximum allowed plate size) should be given. • Maximum allowed width of the heat exchanger should also be given.

2.2 Pressure Differences

The pressure difference that each plate in the heat exchanger experiences must never be so high that the plate will be permanently deformed (i.e., the stress in the plate may never at any point exceed the yield stress of the material). The maximum pressure difference between the exhaust side and the supply side or the pressure difference between either side and the outside of the heat exchanger must never exceed a given maximum value that varies for different heat exchanger models.

Any pressure differences across heat exchanger plates will cause the channels to deform. Small pressure differences of a few hundred Pascal's will hardly be measurable but at higher pressure differences the channel with the relatively higher pressure will expand (pressure drop will decrease) and the channel with the lower pressure will contract (pressure drop will increase).

Be aware of that the performance (efficiency, pressure drop) that is calculated for an air-to-air plate heat exchanger as a component is valid under the following conditions:

- The velocity profiles entering the heat exchanger should be completely even, i.e. the mass flows must be the same in all parts of the heat exchanger.
- The temperature profiles entering the heat exchanger should also be completely even.

These are the only realistic conditions upon which a general calculation of air-to-air plate heat exchangers can rely. It also makes it possible to compare the performance of different exchangers correctly. All deviations from these conditions will reduce the heat exchangers' efficiency. A technically correct result considering given effects due to uneven velocity and/or temperature over the exchanger can only be evaluated when the corresponding profile is known.

An even velocity distribution is best achieved by the following:

- Avoid sharp bends immediately before and after the heat exchanger.
- Place the fans on the exit side of the heat exchanger, so they are pulling air through the exchanger.

If the pressure drop in the heat exchanger is very low, then a more even air distribution can be achieved by placing a filter (or another restriction) that creates a pressure drop before the heat exchanger.

Should it not be possible to allow for enough space around the heat exchanger and/or a favorable location of the fans, it could result in performance reduction (i.e., lower efficiency and higher pressure drop).

The size of the reduction will depend on several parameters and their interactions with each other and may be calculated using CFD methods or estimated from measurements in tests.

It is possible to reclaim some of the performance loss by introducing sheet metal guides or other arrangements in the unit, which will deflect and distribute the airflows more uniformly at the heat exchanger inlets.

Calculated values of pressure drop in the heat exchanger are always presented at zero pressure difference in accordance with the European norm EN 308 and its subdocuments. These state that pressure difference shall be zero and that velocity and temperature profiles entering the heat exchanger shall be uniform. In Heatex Select the effect of pressure differences can be calculated if a differential pressure is entered.



NOTE! Deviations from EN 308 air flow characteristics will reduce the performance of the heat exchanger.

2.3 Temperatures

High and low temperatures impact the heat exchanger in different ways when it comes to sealings, leakage and condensation.

2.3.1 High temperatures

High air or surrounding temperatures have two main consequences; material selection and leakage level. Up to 90°C Heatex standard options can be used without any limitation. Above 90°C, silicone sealing is needed, and the glue in the folds is omitted, which impacts the leakage level. A complete aluminum or stainless steel frame is recommended at even higher temperatures. For specific limits, see each specific product section.

2.3.2 Low temperatures

Higher efficiency of the exchanger increase the amount of condensing water and lower the temperature in the exchanger. Potentially, condensation combined with low plate temperatures could occur. In worst case this would require bypass or standstill to defrost.

Therefore, it is not always the case that more energy can be recovered with an exchanger with high efficiency than with one with a lower efficiency if the average over a whole year is taken into account.



NOTE! Minimum allowed temperature for all plate heat exchangers is -40 °C (-40°F).

2.3.3 Condensation

Condensation is a phenomenon that takes place when an airstream containing water vapor is cooled down to the condensation temperature. At atmospheric pressure, the condensation temperature depends on air temperature and water content of the air (relative humidity or absolute moisture content).

As an example, the condensation temperature is given below for a few examples.

Temperature	Relative Humidity	Absolute Moisture (kg or lbs water/kg or lbs dry air)	Condensation Temp
20°C (68°F)	40%	0.0059 kg (0.0130 lbs)	6.0°C (42.8°F)
20°C (68°F)	20%	0.0029 kg (0.0064 lbs)	-3.6°C (25.5°F)
40°C (104°F)	20%	0.0093 kg (0.0205 lbs)	12.8°C (55.0°F)
100°C (212°F)	10%	0.0701 kg (0.1545 lbs)	46.1°C (114.9°F)

Condensation will increase the supply air efficiency in the wintertime because the latent heat released when water vapor condenses into liquid water always increase the supply air temperature and thus improve the efficiency on the supply side. However, efficiency on the exhaust side will be lower.

Heavy condensation may cause a moderate increase in pressure drop on the exhaust side of the plate heat exchanger.

Heatex Select calculates the amount of condensing water but the calculation is limited to moisture contents of about 0.15 kg (0.33 lbs) water per kg (lbs) of dry air. Which is a substantial amount of water in the air, corresponding to about 60°C (140°F) and 100% RH.

The plate heat exchanger should be oriented so that the condensing water can easily flow downward, and means to collect the water and drain it from the unit should be available. Also, ensure that the condensate can leave the heat exchanger without restricting the airflow. A downward flow will work in the same direction as gravity at all air velocities and is the best way to ensure that the water leaves the heat exchanger.

Remember that air velocities below about 3 m/s, the airstream will not carry water.

In general, moderate concentrations of exhaust air containing corrosive vapors will not damage the heat exchanger surfaces unless condensation occurs. However, even if, during regular running, no condensation will occur, it can happen during the start-up or shutdown of the unit, and it is vital to vent out the unit thoroughly when it has been closed down.

Should there be a lot of condensation in the heat exchanger, limestone and other contaminants may deposit on the surfaces, which will, in time, influence the exchanger's performance. Therefore provisions should be made to provide access for cleaning.



NOTE! Completely horizontal plates should be avoided.

2.3.4 Freezing

Freezing will occur if the exhaust air is cooled down to the condensation temperature so that condensation takes place and the condensing water then comes into contact with a plate surface that has a temperature below 0°C (32°F). The condensing temperature of the air depends on the temperature and relative humidity of the air when it enters the heat exchanger. Air containing a lot of water will have a high condensing temperature.

In a cross flow heat exchanger, the temperature distribution of the exiting air is uneven, and there will be one “warm” and one “cold” corner of the exchanger. If freezing occurs, it will start in the cold corner and the exhaust airflow will then gradually decrease because of the blocking of the exhaust channel. If nothing is done this can continue until the exhaust side is completely blocked. The ice (or snow) will affect operation and might also damage the plates.

Heatex Select will give an indication of at which outdoor temperature freezing in the heat exchanger may start to take place.

One of the most common ways to prevent freezing is by totally bypassing the cold supply air when it is below a certain temperature (for example -5°C (23°F)). Another way is to by-pass only part of the cold air stream, just enough so that freezing does not start. By mechanically blocking part of the heat exchanger the flow in the cold corner can be reduced and thus prevent freezing. Another common way is to use a heater to heat the supply air before it is entering the heat exchanger.

2.4 Leakage

The exchanger will always have some leakage. Therefore, it should be considered when designing the air-handling unit to ensure leakage occurs from “the clean” to the “less clean” side by providing a higher pressure on the “clean side” than on the other side. For example, if water is unacceptable to leak over to the supply side, the design of the air handling unit must be made in such a way that there always will be a higher pressure on the supply side than on the exhaust side.

2.4.1 Air tightness

Air by-passing the heat exchanger or leakage between the two sides of the heat exchanger will reduce performance and may also carry particles, odors, and condensate between the two sides. Therefore, a sealing between the heat exchanger frame and the air handling unit is critical, just as the internal leakage in the heat exchanger must be as small as possible. As a standard, Heatex puts glue in the foldings and corners of all plate heat exchangers to minimize leakage.

Because plate heat exchangers have extremely low leakage—typically under 0.1% of the nominal airflow—compared to rotary heat exchangers, EATR/OACF calculations for air handling units can assume no leakage contribution for the plate heat exchanger.

For water tightness and an even higher level of air tightness, Heatex offers “AquaSeal”, a process used to fill all plate crevices with a special polymer. It results in a highly tight heat exchanger, suitable for applications with high humidity or direct water exposure, such as adiabatic cooling and swimming pool applications, etc. As standard, for every heat exchanger applied with “AquaSeal”, a water tightness test is performed at 400 Pa (1.6” WC) for 20 minutes.

For applications at higher temperatures than 90°C (190°F), the glue in the foldings is omitted since it will melt at this temperature. As a result, the leakage will be slightly higher, see specifications in chapter 3 and 4.

Air tightness test

For applications at higher temperatures than 90°C (190°F), the glue in the foldings is omitted since it will melt at this temperature. Leakage tests are available for plate heat exchangers up to plate size 1200mm. The test is conducted by placing the heat exchanger in the test rig and sealing the structure around it. Then, the fan power is adjusted to reach the required pressure differential.

Smaller (H 200 - H 300) plate heat exchangers are tested at 250 Pa and larger (H 415 - H2 1200) plate heat exchangers at 400 Pa pressure differential. The leakage flow is measured with a measuring tube. The leakage is the ratio of leakage flow and the nominal flow for the specified configuration. The nominal flow is the flow rate where the plate heat exchanger reaches a pressure drop of 50 Pa (H 200 - H 300) or 200 Pa (H 415 - H2 1200) across the plate heat exchanger with a width of 1000 mm.

The test conditions and definition of the nominal flow rate are according to EN308. The calculated leakage (in percentage) is presented in a test protocol. It is approved or not, depending on the value and the allowed limits for the specific plate heat exchanger model.

2.4.2 Water tightness

All leakage levels are valid per single heat exchanger. In general, pressure should be highest on the side that needs to be protected against leakage/contamination. For water tightness and an even higher level of air tightness, Heatex offers “AquaSeal”, a process used to fill all plate crevices with a special polymer. It results in a highly tight heat exchanger, suitable for applications with high humidity or direct water exposure, such as adiabatic cooling, swimming pool applications, etc. As standard, for every heat exchanger applied with “AquaSeal”, a water tightness test is performed at 400Pa (1.6” WC) for 20 minutes.

Water tightness test

The order must include a water tightness test if water tightness is requested. Heatex guarantees water tightness at delivery from Heatex premises. The test is conducted by creating a 40mm water pillar in the heat exchanger (400Pa differential pressure) for 20min. Any leakage is detected visually, and the criteria are zero leakage during the test period. All four sides of the cube are tested.



NOTE! Water tightness is only guaranteed from Heatex premises since transport might impact tightness.

2.4.3 IP rating

IP 65 suitable heat exchangers available on request.

2.5 Media Compability

Most of Heatex plate heat exchangers are manufactured in aluminum or epoxy coated aluminum. The aluminum plate heat exchangers have end plates made of Aluzinc or aluminum depending of size. Corner profiles are made of aluminum.

Stainless heat exchangers are manufactured in SS 316L (acid resistant). Framework of these heat exchangers are also made of stainless steel.

Aluminum material

Alloy	8006/8009/8011/8111/1200
Temper	H00/H19

Epoxy coated aluminum material

Epoxy-phenolic gold color paint	
No toxic organic paint, as declared from Paint Producers "SUITABLE FOR FOOD CONTACT" as for Italian "Ministry Decree", "D.M. 220" of the 26.04.93 (issued in accordance with EEC Directives)	
Total grammage per side	6 +/- 1 gr/m2 corresponding to 5 +/- 1 microns

Mechanical characteristics of the paint

Pencil hardness (KOH-I-NOOR)	H
M.E.K. Resistance	50 double passing
Bending flexibility (ECCA T7)	OT without adhesion loss
Indentation, "cupping test", acc. EN 13523-6	No paint detachment before metal support breaking (aluminum)

Others characteristics

1.1.1. Trichloroethane resistance	No paint detachment
Resistance to pressing lubricant	Good
Resistance to thermal shock (according to AICC N 13)	No alteration



NOTE! Epoxy coatings are not UV resistant. Epoxy coated surfaces should therefore never be exposed to sunlight, neither in installations nor during storage.

The below table is a guide for choosing material when different substances are present in the airstream. This information is accurate to our knowledge, but no guarantee is expressed nor implied in the application or services over which Heatex has no control. Heatex recommends that tests are made to verify that the selected material will work in the actual application.

Resistance to fumes at normal temperatures				
A=Excellent	B=Good	C=Fair	D=Poor	*=No Information

Substance	Formula	Aluminum	Epoxy Coated Alu.	Stainless Steel 316L	Sealing Silicone free
Acetic Acid	CH ₃ COOH	A	A	A	C
Acetone	C ₃ H ₆ O	A	A	A	C
Ammonium Hydroxide	NH ₄ OH	D	A	A	B

Substance	Formula	Aluminum	Epoxy Coated Alu.	Stainless Steel 316L	Sealing Silicone free
Ammonium Sulfate	$(\text{NH}_4)_2\text{SO}_4$	C	A	A	B
Bakery Vapors		A	A	A	A
Beer		A	A	A	C
Benzene	C_6H_6	A	*	A	*
Boric Acid	H_3BO_3	A	A	A	*
Calcium Chloride	CaCl_2	B	A	C	B
Carbon Dioxide	CO_2	A	A	A	A
Carbon Tetrachloride	CCl_4	B	*	C	D
Carbonic Acid	H_2CO_3	A	A	A	*
Chlorine, water		C	A	C	B
Chloroform	CHCl_3	*	*	A	D
Chromic Acid	CrO_3	B	B	B	D
Citric Acid	$\text{C}_6\text{H}_8\text{O}_7$	B	A	A	*
Copper Cyanide	CuCN	D	*	*	*
Creosote		*	*	*	*
Diesel Oil		A	A	A	D
Ethyl Alcohol	$\text{C}_2\text{H}_5\text{OH}$	A	A	A	D
Ethylene Dichloride	$\text{C}_2\text{H}_4\text{Cl}_2$	*	*	*	*
Fatty Acids		B	A	A	*
Ferric Chloride	FeCl_3	D	A	*	*
Fluorine Gas	F_2	D	*	D	*
Formaldehyde	CH_2O	*	A	A	*
Fruit Vapors		A	A	A	A
Fuel Oil		A	A	A	B
Gasoline		A	A	A	*
Glycerin	$\text{C}_3\text{H}_8\text{O}_3$	A	*	A	C
Glycol	$\text{C}_2\text{H}_6\text{O}_2$	A	*	A	*
Hydrochloric Acid	HCl	D	A	D	D
Hydrocyanic Acid	HCN	*	*	C	*
Hydrofluoric Acid	HF	D	A	D	*
Hydrogen Peroxide	H_2O_2	C	B	A	D
Hydrogen Sulfide	H_2S	D	A	B	D
Jet Fuel		A	A	A	D
Kerosene		A	A	A	D
Lactic Acid	$\text{CH}_3\text{CHOH}-\text{COOH}$	C	A	A	C
Lube Oils		A	A	A	*
Mercury	Hg	*	*	*	*
Milk		A	A	A	B
Mineral Thinner		A	*	A	*
Molasses		A	A	A	*
Nitric Acid	HNO_3	B	*	A	D
Oils & Fats		B	A	A	B
Oleic Acid	$\text{CH}_3(\text{CH}_2)_7\text{CH}-\text{CH}(\text{CH}_2)_7\text{COOH}$	B	*	*	*
Oxalic Acid	$\text{C}_2\text{Cl}_2\text{O}_2$	C	*	C	D

Substance	Formula	Aluminum	Epoxy Coated Alu.	Stainless Steel 316L	Sealing Silicone free
Petroleum Oils		A	A	A	C
Phosphoric Acid	H ₃ PO ₄	*	A	A	B
Photographic Chemicals		*	B	A	*
Potassium Permanganate	KMnO ₄	*	*	A	*
Silver Cyanide	AgCN	*	*	*	*
Soaps		C	A	A	B
Sodium Hydroxide	NaOH	D	B	A	D
Sodium Hypochlorite	ClONa	D	B	C	D
Stearic acid	C ₁₈ H ₃₆ O ₂	B	A	A	*
Sulfur Dioxide	SO ₂	D	D	A	*
Sulfuric Acid	H ₂ SO ₄	C	B	A	D
Sulfurous Acid	H ₃ SO ₃	C	A	A	*
Syrups		A	A	A	B
Tannic Acid	C ₇₆ H ₅₂ O ₄₆	C	A	A	*
Tetrahydrofuran	C ₄ H ₈ O	*	*	A	*
Toluene	C ₇ H ₈	A	A	A	*
Tricresyl phosphate	(CH ₃ C ₆ H ₄ O) ₃ PO	B	*	A	*
Turpentine		A	B	A	*
Urine		D	B	A	C
Vegetable Oils		A	A	A	B
Vegetable Vapors		A	A	A	A
Vinegar		D	A	A	*
Vinyl Acetate	C ₄ H ₆ O ₂	*	*	A	*
Water, Fresh		A	A	A	B
Water, salt		D	A	A	B
Whiskey		A	A	A	C
Wine		*	A	A	C
Xylene	C ₈ H ₁₀	A	*	A	*
Zinc Sulfate	ZnSO ₄	D	A	B	*

2.6 Orientation

There are three main ways to install a cross flow heat exchanger. Diamond (diagonally) installation is the most common in ventilation air handling units. Both inlet air streams are entering from the top which has two benefits. Condensate is easier removed from the heat exchanger and any heavy air post treatment equipment can be installed on the lower deck of the air handling unit.

For a diagonally mounted heat exchanger (which in itself will create some non uniformity of the airflows), it is essential to have enough room above and below the heat exchanger so that the air flows can distribute evenly and perpendicular to the inlets.

To ensure that the heat exchanger is not affected by a too narrow enclosure, leave space equal to half the diagonal dimension of the heat exchanger between the heat exchanger corner and the top or bottom wall, respectively (i.e., the internal height of the enclosure should be twice the heat exchanger diagonal).

Vertical installation is more common in applications such as industrial heat recovery or adiabatic data center cooling. The installation enables easy removal of condensate and if water is sprayed into the heat exchanger it is easier to distribute it evenly in the heat exchanger.

Horizontal installation has no obvious advantage over diamond or vertical installation. It is mainly used when the air streams are side by side. If there is a risk for condensation in the heat exchanger, try to avoid horizontal plates. A large amount of condensed water together with low air velocity might lead to water accumulation and thus damage the heat exchanger and/or reduce the efficiency. Installing the heat exchanger with an inclination of just a few degrees will in most cases be enough to drain the condensate. Some cross flow heat exchangers (mainly with low channel heights) need to be produced in more than one cube to avoid deformation of the plates due to gravity. Heatex tolerance is 20mm vertical sag/deformation.

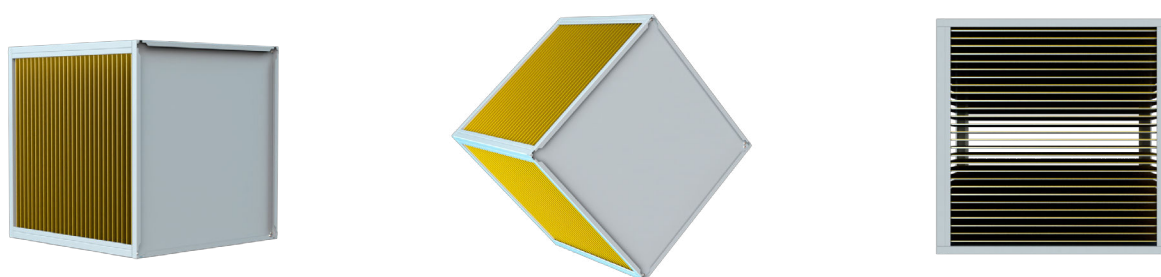

Image 1. Vertical, diamond & horizontal orientation

2.7 Configuration

A cross flow heat exchanger can be configured in 1- or 2-steps. 1-step is a heat exchanger where the air passes the heat exchanger once. A 2-step configuration consist of two heat exchangers connected in series. The air passes through both heat exchanger in a counter flow arrangement. The benefit with 2-step is the increased thermal efficiency. The drawback is a higher pressure drop.

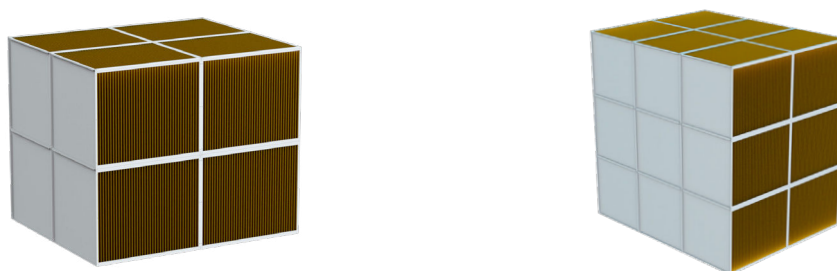

Image 2. Multimodules

A cross flow can be combined to form multi modules. Four 1000x1000 mm heat exchanger can be combined into a 2000x2000 mm heat exchanger. Nine can be combined into a 3000x3000 mm heat exchanger.

By increasing the width of a cross flow heat exchange the capacity can be increased or pressure drop decreased. Two 1000 mm wide heat exchangers are combined into a 2000 mm wide multimodule by using a joining kit to hold them together.

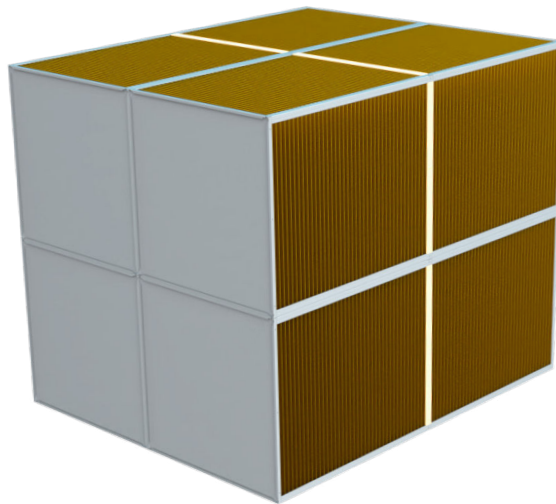

Image 3. Joining kit

2.7.1 Two Steps

The amount of steps describes the amount of individual plate heat exchangers mounted after each other. There are “diamond” and “vertical” configuration.

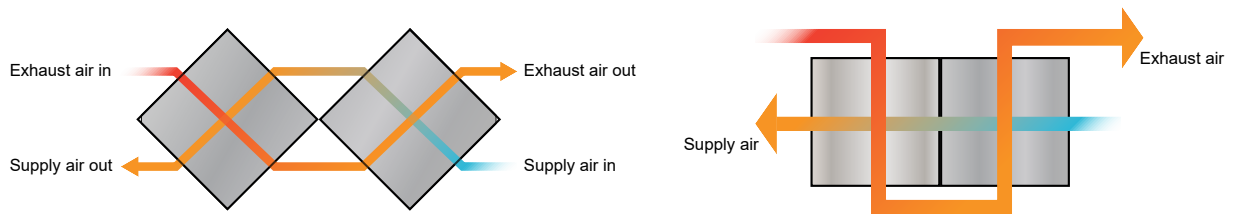

Image 4. Two steps

2.8 Sound Dampening

A plate heat exchanger tends to dampen sound in a ventilation system. The dampening depends on the heat exchanger size and plate distance. Below is a guide to the dampening effect at different frequencies. There are slight differences among models. These values can be used for any cross-flow heat exchanger as guidance. However, the overall AHU design also impacts sound dampening.

Exchanger Plate size	Plate distances	63 Hz	125 Hz	250 Hz	500 Hz	1000 Hz	2000 Hz	4000 Hz	8000 Hz
200	1.6-2.7	1	2	2	3	3	3	4	4
300	1.8-5.0	1	2	2	3	3	3	4	4
415/425	3.3-6.5	1	2	2	3	4	4	4	4
600	1.9-6.0	2	4	4	6	7	8	9	9
600	7.5-12.0	1	2	2	4	4	5	5	5
700	2.0-6.0	2	4	4	6	6	8	9	9
750/800	3.3-6.0	2	5	5	7	8	10	11	11
750/800	7.5-12.0	1	2	2	4	4	5	6	6
850	2.0-6.5	2	5	5	7	8	10	11	11
850	8.0-9.5	1	2	2	4	4	5	6	6
1000	2.0-6.0	3	5	5	8	9	11	12	13
1000	7.5-12.0	2	4	4	6	7	8	9	9
1200	2.0-6.0	3	5	5	8	9	11	12	13
1200	7.5-12.0	2	5	5	7	8	10	12	12
1400	2.0-6	3	6	6	8	10	11	13	13
1500	2.0-6.0	3	6	6	9	10	11	13	13
1500	7.5-12.0	3	5	5	8	9	11	12	13
1700	2.0-6.5	3	6	6	9	10	11	13	13
1700	8.5-12.0	3	5	5	8	9	11	12	13
2000	2.0-6.0	3	7	7	10	11	14	15	15
2000	7.5-12.0	3	6	6	9	10	12	13	14
2250/2400/ 2550/3000	2.0-6.0	4	9	9	12	14	16	19	19
2250/2400/ 2550/3000	6.5-12.0	3	7	7	9	11	13	14	14

2.9 Hygiene

Heatex has certified cross flow plate heat exchangers and dampers according to relevant European standards. The products have been tested and approved for hygienic applications by external institute. Each specific certificate is available on heatex.com

2.10 Installation & Handling

2.10.1 Transportation

In general, cross flow heat exchangers shall always be transported with plates in vertical orientation.

If the heat exchanger is factory assembled in the air handling unit/ heat recovery system with plates in the horizontal position, extra care must be taken during transport. Actions must be taken to avoid any acceleration forces on the AHU and, indirectly, the heat exchanger during loading and transportation. Installing heat exchangers at the end destination is better if this isn't guaranteed.

2.10.2 Handling

In general, don't use the profiles to lift the heat exchanger. Single cubes can be lifted in the end plate if the end plate is type E. For units combined in length or size, Heatex recommends using a flat lifting sling under the heat exchanger. One sling under each section if combined in length (like the picture below).

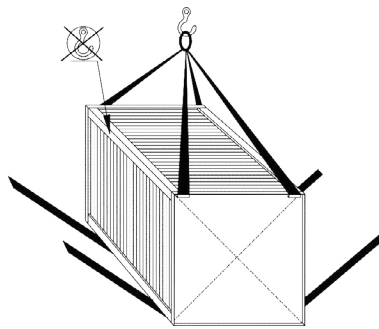

Image 5. Lifting

2.10.3 Installation

The flat surface of the profile and edges of the end plate enables sealing off the heat exchanger towards the AHU surface can be done with a standard sealing strip.

If ducts shall be directly connected to the heat exchanger, it is recommended that self-tapping screws or pop rivets are used. Make sure the length is chosen so that the fastener does not penetrate the heat exchanger channels. In the case of welding, care must be taken not to melt or damage the sealant.



NOTE: A framework that is not straight, irregular channels or any other deformation to the heat exchanger may seriously influence the performance of the heat exchanger.

2.10.4 Disposal

- Plate heat exchanger consists of up to 98 % aluminum depending on size and configuration. (Besides Model Z, which is entirely made out of stainless steel).
- Plates are made of either aluminum or epoxy-coated aluminum and should be disposed of as aluminum.
- End plates are either made of aluminum or carbon steel (sometimes coated or painted) and should be disposed of as aluminum or metal.
- Dampers and bypasses are made out of aluminum and should be disposed of as aluminum.
- An actuator (damper motor) can be attached to the damper and should be treated as electrical waste.
- The glue that holds the plates to the end plate and corner profiles complies with combustible waste.

2.11 Cleaning

All plate heat exchangers have been designed with a plate pattern that allows most of the dirt and pollutants in the air to pass through the heat exchanger. However it is strongly recommended to use a filter before the exchanger to prevent dirt from depositing. A filter will also protect other vital component in the system. Without a filter, substances with the high risk of fouling the exchanger are for example sticky substances condensing on surfaces, fibers from, for example, dry tumblers or particles from paint booth.

Experience has shown that the buildup of dirt in a heat exchanger is often limited to the first 50 mm (1.97") in the exchanger, simplifying cleaning. For regular ventilation applications, it is most of the time sufficient to clean the inlet and outlet with a brush. Compressed air or high-pressure water cleaning and disinfection may be necessary for applications with high concentration of contaminants. Please observe that high-pressure cleaning must not be done directly against the plates and must be kept below 100 bar. In addition, ensure the plate edges do not deform or get perforated when removing dirt mechanically.

The detergent recommended for cleaning is YES/Fairy. The detergent shall be sprayed on the heat exchanger with a low-pressure sprayer. The detergent can be diluted with up to 75% water. YES/Fairy is available in grocery stores and can also be purchased through Heatex. Heatex article number: 42715.

The disinfectant recommended for disinfection is LIV +45. Do not dilute LIV +45 with water. LIV +45 is available for purchase through Heatex. Heatex article number: 42716.



Image 6. YES/Fairy detergent & LIV +45 disinfectant.



NOTE! Account for some additional space to make sure cleaning is possible while designing the AHU.

Cleaning Procedure:

1. Clean the heat exchanger surface with a brush or vacuum cleaner.
2. If required, rinse the heat exchanger with water using a high-pressure washer to remove dust, particles, deposits, etc. Always keep the nozzle at a distance of approximately 300 mm (11") from the heat exchanger to not damage the plates. Adjust the nozzle to the plane jet.
3. Spray the heat exchanger with detergent (YES/Fairy detergent) with a low-pressure sprayer.
4. Clean the heat exchanger plates by spraying water into the area between the plates.
5. Repeat steps 1-4 on each side of the heat exchanger if necessary.

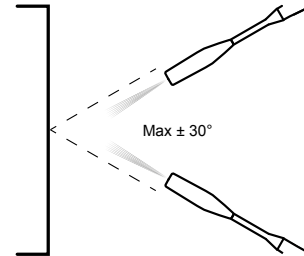

2.11.1 Disinfection

Disinfection might be required depending on application and local requirements.

Disinfecting procedure:

1. Spray the disinfectant into the heat exchanger. Use the standard LIV +45* bottles with easy spray tap.
2. Spray both plates in every channel and if required spray into all four sides of the heat exchanger.
3. Let the heat exchanger air dry for 30 minutes.
4. Rinse the heat exchanger with water, using the cleaning procedure (but without detergent), to assure all disinfectant has been removed.

*Observe that LIV+45 contain alcohol which is flammable. Take precaution to avoid ignition.

3. CROSS FLOW HEAT EXCHANGERS

3.1 Product Code Explanation

Product code example: H21200-0600-030-2E00-1-0-0-0600

	H2	A	1200	0600	030	2	E	OO	1	0	0	0600	Region
Pos.	1	2	3	4	5	6	7	8	9	10	11	12	13

Pos	Configuration	
1	Model	H2, H, P, Z, Z2
2	Plate material	A = Aluminum E = Epoxy coated aluminum T = Double epoxy coated aluminum S = Stainless steel
3	Heat exchanger size (A) (Larger size are usually combined modules)	H2: 500 - 3000 mm H: 200 - 3000 mm P: 600 - 3000 mm Z: 600, 1200, 1800 & 2400 mm Z2: 850, 1700, 2550 mm
4	Exchanger width (B)	Range depends on Model
5	Nominal plate distance	Range depends on Model
6	Corner profile	1 = 45° 2 = 90° 6 = Other profiles
7	End plate	A = Plain endplate C = L-shaped endplate E = U-shaped endplate
8	Additional options	OO = Standard product Otherwise = See options list
9	Sealing	2 = Silicone free (max 90°C) 5 = Silicone (max 240°C) 6 = Other sealing 7 = Silicone (max 200°C)
10	Modules	0 = Single module exchanger 1 = Multi modules exchanger / plate size 2 = Multi modules exchanger / width 3 = Multi modules exchanger / plate size and width 4 = Multi modules exchanger / width / horizontal plates 5 = Multi modules exchanger / plate size and width / horizontal plates 6 = Single module exchanger / horizontal plates 7 = Multi modules exchanger / plate size / horizontal plates

Pos		Configuration
11	Bypass	0 = Without bypass 1 = With bypass 2 = Bypass and damper 3 = Bypass and bypass-damper 4 = Damper without bypass 5 = Bypass in the middle 6 = Bypass in the middle + dampers 7 = Bypass and internal bypass damper 9 = Bypass in the middle + bypass dampers A = Bypass and damper + recirculation damper B = Bypass in the middle and damper + recirculation damper
12	Total width (incl. bypass)	Depending on Model, see Chapter 5 "Models"
13	Region	NA = North American product (AHRI certified) Empty = Eurovent certified

Measurements

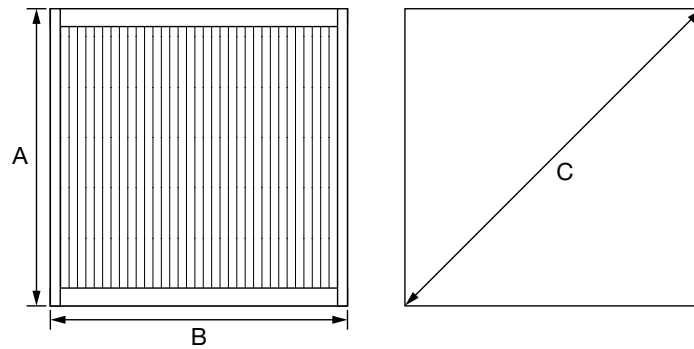

Modules - Plates orientation vertical

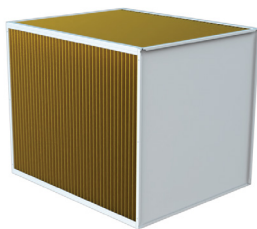

Single module (Option 0)

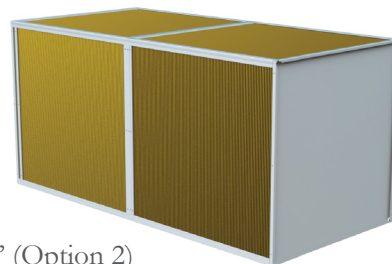

Multi modules "Width" (Option 2)



Multi modules "Plate size" (Option 1)

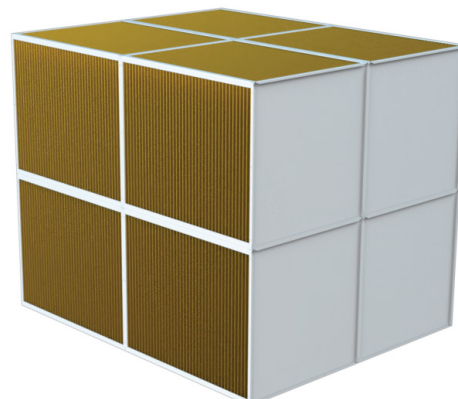

Multi modules "Plate size & width" (Option 3)

Image 7. Single and multimodules

Modules - Plate orientation horizontal

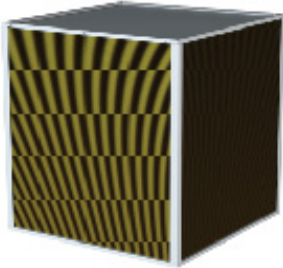

Single module (Option 6)



Multi modules "Width" (Option 4)

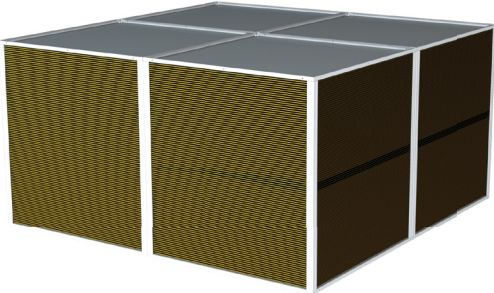

Multi modules "Plate size" (Option 7)

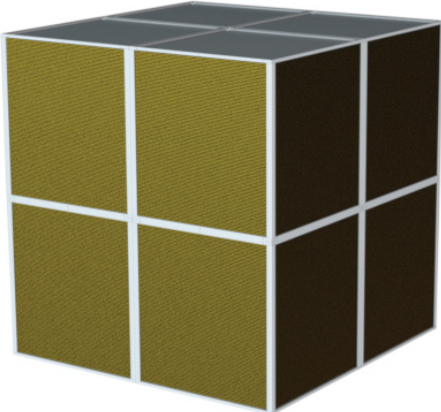

Multi modules "Plate size & width" (Option 5)

Image 8. Single and multimodules

3.2 Model H2

Sizes & plate distance

Model*	A	B**	45° Corner profile	90° Corner profile	Plate distance
500	500	250 - 1000	688	707	1.9 / 2.0 / 2.5 / 3.0 / 4.0 / 5.0 / 6.0
600	600	250-1200	829	849	1.9 / 2.0 / 2.2 / 2.5 / 3.0 / 4.0 / 5.0 / 6.0
700	700	300-1200	970	990	2.0 / 2.5 / 3.0 / 4.0 / 5.0 / 6.0
750	750	300-1200	1041	1061	2.0 / 2.1 / 2.5 / 3.0 / 4.0 / 5.0 / 6.0
850	850	300-1200	1182	1202	2.0 / 2.1 / 2.2 / 2.5 / 3.0 / 4.0 / 5.0 / 6.0
1000	1000	350-1200	1394	1414	2.0 / 2.5 / 2.7 / 3.0 / 4.0 / 5.0 / 6.0
1200	1200	350-1200	On request	1697	2.0 / 2.5 / 2.7 / 2.8 / 3.0 / 4.0 / 5.0 / 6.0 / 8.5 / 10.0
1400	1400	350-1200	1960	1980	2.0 / 2.5 / 3.0 / 4.0 / 5.0 / 6.0
1500	1500	350-1200	2102	2122	2.0 / 2.5 / 3.0 / 4.0 / 5.0 / 6.0
1700	1700	350-1200	2384	2404	2.0 / 2.5 / 3.0 / 4.0 / 5.0 / 6.0
2000	2000	350-1200	2808	2828	2.0 / 2.5 / 3.0 / 4.0 / 4.3 / 4.8 / 5.0 / 6.0
2250	2250	350-1200	3162	3182	2.0 / 2.5 / 3.0 / 4.0 / 5.0 / 5.5 / 6.0
2400	2400	350-1200	3374	3394	2.0 / 2.5 / 2.7 / 2.8 / 3.0 / 4.0 / 5.0 / 5.5 / 6.0 / 8.5 / 10.0
2550	2550	350-1200	3586	3606	2.0 / 2.5 / 3.0 / 4.0 / 5.0 / 6.0
3000	3000	350-1200	4223	4243	2.0 / 2.5 / 3.0 / 4.0 / 5.0 / 6.0

* Models up to 1200 consist of one single plate heat exchanger.

** Maximum module width depends on plate orientation (vertical or horizontal), model and plate distance.



NOTE: Maximum module width depends on plate orientation (vertical or horizontal), model and plate distance.

Joining rules

Plate distance, h (mm)	Joining length B1 (mm)						
	H2 500	H2 600	H2 700	H2 850	H2 1000	H2 1200	
1.9 (0.075") ≤ h < 2.5 (0.098")	1000	1200	1200	1150	1050	650	
2.5 (0.098") ≤ h < 3.0 (0.118")				1200	1100	750	
3.0 (0.118") ≤ h < 3.5 (0.138")					1150	850	
3.5 (0.138") ≤ h < 4.0 (0.16")					1200	950	
4.0 (0.16") ≤ h < 4.5 (0.18")						1200	1100
4.5 (0.18") ≤ h							1200

* For horizontally oriented plates similar joining rules apply but in some cases an integrated support plate is required. For specifics see Heatex Select.

Components

Component	Material
Plate material	<ul style="list-style-type: none"> Aluminum Epoxy coated aluminum Double epoxy coated aluminum
End plates	<ul style="list-style-type: none"> Aluzinc
Corner profiles	<ul style="list-style-type: none"> Aluminum 90° Aluminum 45° (not available on H2 1200)
Sealing	<ul style="list-style-type: none"> Silicone free (max 90°C (190°F)) Silicone (max 200°C (390°F)) Silicone (max 240°C (464°F))

Maximum allowed differential pressure

Plate distance	Max. allowed differential pressure
2.0-2.2	1800 Pa (7.2" WC)
2.5-2.8	2000 Pa (8.0" WC)
3.0	2200 Pa (8.8" WC)
≥4.0:	>3000 Pa (>12" WC)
For H2 1200 & 2400:	
2.0	1500 Pa (6.0" WC)
2.5	1600 Pa (6.4" WC)
2.7-3.0	1700 Pa (6.8" WC)
≥4.0	>3000 Pa (>12" WC)

Maximum air leakage

Tested at 400 Pa (1.6" WC) differential pressure.

- Max. 0.1% of nominal airflow with non-silicone sealant
- Max. 1% of nominal airflow with silicone sealant

Leakage limit is per single unit.

Maximum water leakage

0 ml water leakage when applied with Aquaseal. Test is conducted for 20min at 40mm water pillar (400Pa). During that time no leakage is allowed. Leakage limit is for single cube or multimodule exchanger/ plate sizes.

Effect of pressure difference on pressure drop

The below graph indicates the relative pressure drop increase on exhaust side if a positive overpressure is applied on supply side. The ratio represents how much exhaust pressure drop increase in relation to zero differential pressure. The supply pressure drop decrease with the same ratio.

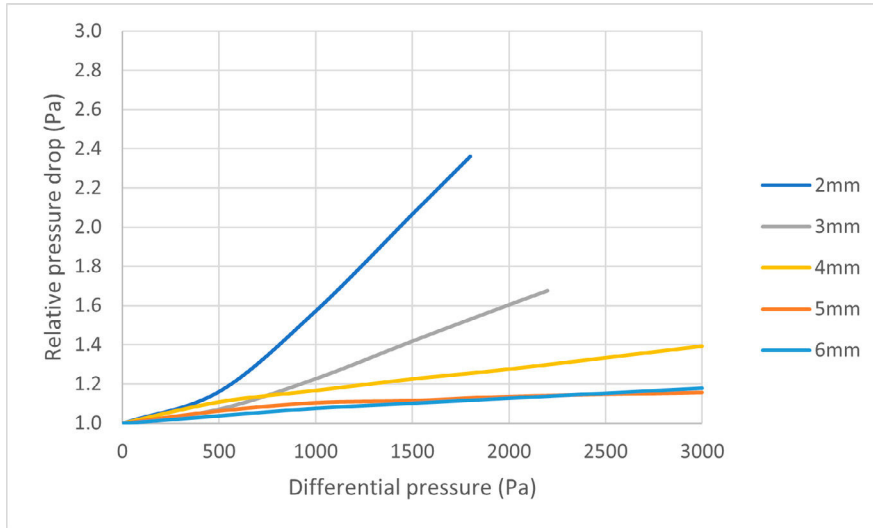

Effect of pressure difference on pressure drop 1200 & 2400

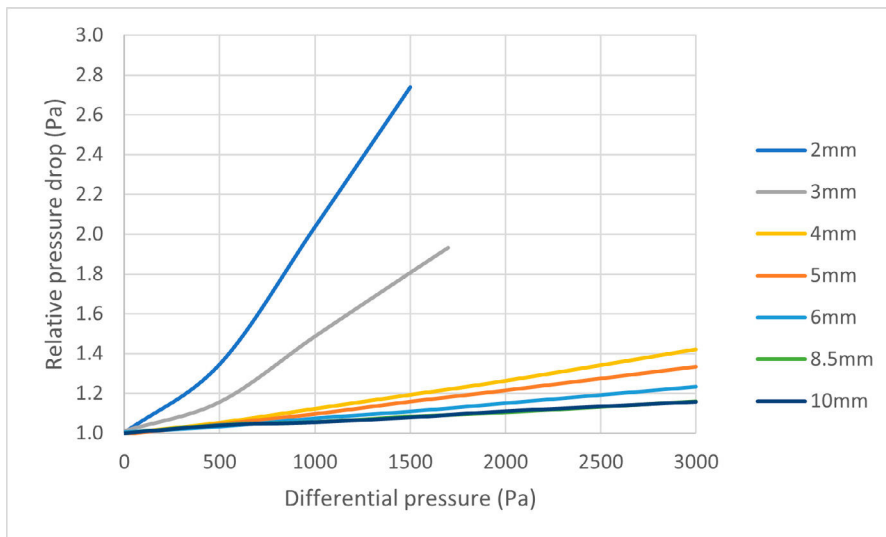

3.3 Model H

Sizes & plate distance

Model	A (mm)	B (mm)	45° Corner profile	90° Corner profile	Plate distance
200	200	100-600	265	283	1.6/2.1/2.4/2.7
250	250	100-600	265	283	1.8/2.1/2.4/3.0/4.0
300	300	100-600	406	424	1.8/2.2/3.0/4.0/5.0
415	415	200-700	548	587	3.3/4.2/5.0/6.5
425	425	200-1000	587	601	3.3/4.2/5.0/6.5
600	600	250-1200	829	849	2.7/3.0/4.5/6.0/7.5/9.0/10.5/12.0
750	750	300-1200	1041	1061	3.3/4.5/6.0/7.5/9.0/10.5/12.0
800	800	300-1200	-	1131	3.3/4.5/6.0/7.5/9.0/10.5/12.0
850	850	300-1200	1182	1202	3.0/3.5/4.0/5.0/6.5/8.0/9.5
1000	1000	350-1200	1394	1414	3.3/3.7/5.0/6.0/7.5/9.0/10.5/12.0
1200	1200	350-1200	1677	1697	2.7/3.0/4.5/6.0/7.5/9.0/10.5/12.0
1500	1500	350-1200	2102	2122	3.3/4.5/6.0/7.5/9.0/10.5/12.0
1700	1700	350-1200	2384	2404	3.0/4.0/4.5/5.0/6.5/8.5/10.5/12.0
2000	2000	350-1200	2808	2828	3.3/3.7/5.0/6.0/7.5/9.0/10.5/12.0
2250	2250	350-1200	3162	3182	3.3/4.5/6.0/7.5/9.0/10.5/12.0
2550	2550	350-1200	3586	3606	3.0/4.0/4.5/5.0/6.5/8.5/10.5/12.0
3000	3000	350-1200	4223	4243	5.0/6.0/7.5/9.0/10.5/12.0

NOTE: For Model H in horizontal orientation the following restrictions regarding maximum module width must however be considered to fall below the maximum allowed vertical sag/deformation of 20mm:



For H0600 with plate distance 2.7 (0.106") and 3.0 mm (0.118") and for H0850 with plate distance 3.0 (0.118"), 3.5 (0.138") and 4.0 mm (0.157") a maximum module width of 800 mm (31.49") is allowed. Wider applications may be constructed using two (or more) exchanger blocks.

For all other plate distances (smaller and bigger) full maximum module width is applicable.

Components

Component	Material
Plates	<ul style="list-style-type: none"> Aluminum Epoxy coated aluminum
End plates	<ul style="list-style-type: none"> Aluzinc (plate size \geq 425 mm (16.73")) Aluminum (plate size \leq 415 mm (16.33"))
Corner profiles	<ul style="list-style-type: none"> Aluminium 90° Aluminium 45°
Sealing	<ul style="list-style-type: none"> Silicone-free (max. 90°C (190°F)) Silicone (max. 200°C (390°F)) Silicone (max. 240°C (464°F))

Maximum allowed differential pressure

- 700 Pa (2.8" WC) for size 200 mm (8.87") and 300 mm (11.81")
- 1800 Pa (7.2" WC) for all other sizes

Maximum air leakage

- 0.1% of nominal air flow for sizes ≥ 600 mm (23.62") at 400 Pa (1.6" WC) with non-silicone sealing
- 1% of nominal airflow for sizes ≤ 425 mm (16.73") at 250 Pa (1" WC) with non-silicone sealing
- 1% of nominal airflow for all models with silicone sealant

Maximum water leakage

0 ml water leakage when applied with Aquaseal. Test is conducted for 20min at 40mm water pillar (400Pa). During that time no leakage is allowed. Leakage limit is for single cube or multimodule exchanger/ plate sizes.

Effect of pressure difference on pressure drop

The below graph indicates the relative pressure drop increase on exhaust side if a positive overpressure is applied on supply side. The ratio represents how much exhaust pressure drop increase in relation to zero differential pressure. The supply pressure drop decrease with the same ratio.

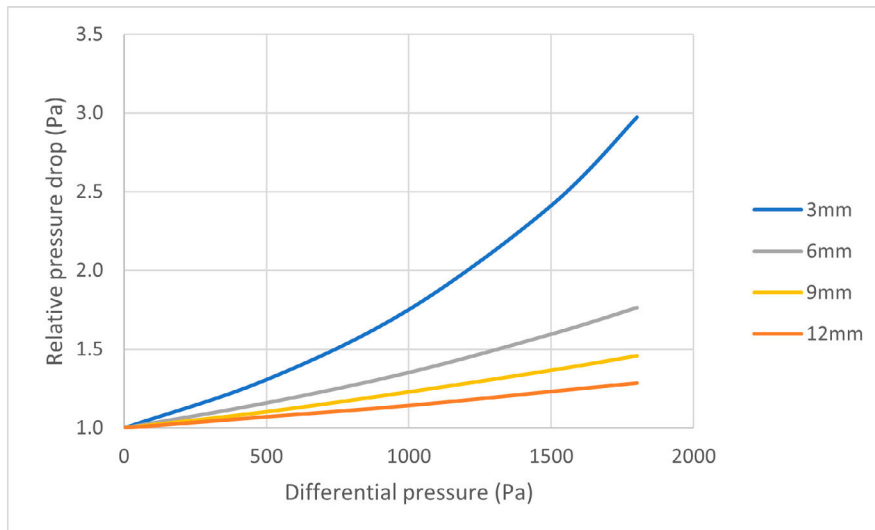

3.4 Model P

Sizes & plate distance

Model	A (mm)	B (mm)	45° Corner profile	90° Corner profile	Plate distance
600	600	250-1200	829	849	2.7/3.3/4.5/6.0/7.5/9.0/10.5/12.0
750	750	300-1200	1041	1061	3.3/4.5/6.0/7.5/9.0/10.5/12.0
850	850	300-1200	1183	1202	3.0/3.5/4.0/5.0/6.5/8.0/9.5
1000	1000	350-1200	1394	1414	3.3/3.7/5.0/6.0/7.5/9.0/10.5/12.0
1200	1200	350-1200	-	1697	2.7/3.0/4.5/6.0/7.5/9.0/10.5/12.0
1500	1500	350-1200	-	2122	3.3/4.5/6.0/7.5/9.0/10.5/12.0
1700	1700	350-1200	-	2404	3.0/3.5/4.0/5.0/6.5/8.5/10.5/12.0
2000	2000	350-1200	-	2828	5.0/6.0/7.5/9.0/10.5/12.0
2250	2250	350-1200	-	3182	3.3/4.5/6.0/7.5/9.0/10.5/12.0
2250	2250	350-1200	-	3606	3.0/3.5/4.0/5.0/6.5/8.5/10.5/12.0
3000	3000	350-1200	-	4243	5.0/6.0/7.5/9.0/10.5/12.0



NOTE: Model P has no restrictions for horizontal orientations.

Components

Component	Material
Plates	<ul style="list-style-type: none"> Aluminum Epoxy coated aluminum
End plates	<ul style="list-style-type: none"> Aluzinc
Corner profiles	<ul style="list-style-type: none"> Aluminum 90° Aluminum 45°
Sealing	<ul style="list-style-type: none"> Silicone-free (max. 90°C (190°F)) Silicone (max. 200°C (390°F)) Silicone (max. 240°C (464°F))

Maximum allowed differential pressure:

- 3800 Pa (15.3" WC)

Maximum air leakage

Tested at 400 Pa (1.6" WC) differential pressure.

- Max. 0.1% of nominal airflow with non-silicone sealant
- Max. 1% of nominal airflow with silicone sealant

Maximum water leakage

0 ml water leakage when applied with Aquaseal. Test is conducted for 20min at 40mm water pillar (400Pa). During that time no leakage is allowed. Leakage limit is for single cube or multimodule exchanger/ plate sizes.

Effect of pressure difference on pressure drop

The below graph indicates the relative pressure drop increase on exhaust side if a positive overpressure is applied on supply side. The ratio represents how much exhaust pressure drop increase in relation to zero differential pressure. The supply pressure drop decrease with the same ratio.

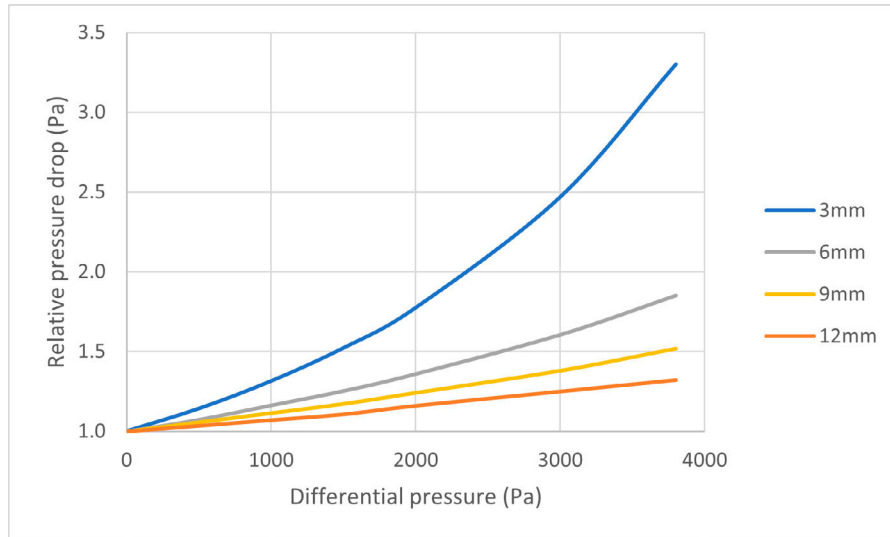

3.5 Model Z

Sizes & plate distance

Model	A (mm)	B (mm)	90° Corner profile	Plate distance
600	600	250-1200	849	3.0 / 6.0 / 7.5 / 9.0
1200	1200	350-1200	1697	3.0 / 6.0 / 7.5 / 9.0
1800	1800	350-1200	2546	3.0 / 6.0 / 7.5 / 9.0
2400	2400	350-1200	3394	3.0 / 6.0 / 7.5 / 9.0

Components

Component	Material
Plates	<ul style="list-style-type: none"> Stainless steel 1.4404 (ASTM 316L)
End plates	<ul style="list-style-type: none"> Stainless steel 1.4404 (ASTM 316L)
Corner profiles	<ul style="list-style-type: none"> Stainless steel 1.4404 (ASTM 316L) 90°
Sealing	<ul style="list-style-type: none"> Silicone-free (max. 90°C (190°F)) Silicone (max. 200°C (390°F)) Silicone (max. 240°C (464°F))

Maximum allowed differential pressure

- 4000 Pa (16.1" WC)

Maximum air leakage

Tested at 400 Pa (1.6" WC) differential pressure.

- 0.1% of nominal airflow with non-silicone sealant (with AquaSeal)
- 0.5% of nominal airflow with non-silicone sealant (without AquaSeal)
- 5% of nominal airflow with silicone sealant (without AquaSeal)



NOTE: Model Z's leakage level is higher than 1% without glue in the foldings.

Maximum water leakage

0 ml water leakage when applied with Aquaseal. Test is conducted for 20min at 40mm water pillar (400Pa). During that time no leakage is allowed. Leakage limit is for single cube or multimodule exchanger/ plate sizes.

Effect of pressure difference on pressure drop

The below graph indicates the relative pressure drop increase on exhaust side if a positive overpressure is applied on supply side. The ratio represents how much exhaust pressure drop increase in relation to zero differential pressure. The supply pressure drop decrease with the same ratio.

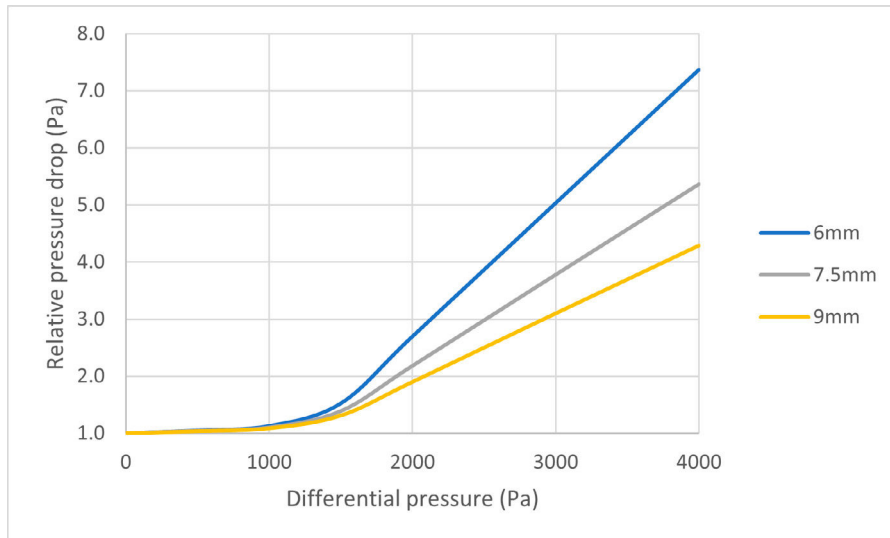

3.6 Model Z2

Sizes & plate distance

Model	A (mm)	B (mm)*	90° Corner profile	Plate distance
850	850	250-1000*	1182	2.2 / 2.5 / 3.0 / 4.0 / 5.0
1700	1700	350-1000*	2384	2.2 / 2.5 / 3.0 / 4.0 / 5.0
2550	2550	350-1000*	3586	2.2 / 2.5 / 3.0 / 4.0 / 5.0

* B is length of one single plate heat exchanger, wider heat exchanger needs to have joining

** Maximum length of single PHE is limited by plate distance (see table bellow)

Joining Rules

Plate distance	B (mm)
$2.2 \leq h < 3.0$	540
$3.0 \leq h < 4.0$	700
$4.0 \leq h$	1000

Components

Component	Material
Plates	<ul style="list-style-type: none"> Stainless steel 1.4404 (ASTM 316L)
End plates	<ul style="list-style-type: none"> Stainless steel 1.4404 (ASTM 316L)
Corner profiles	<ul style="list-style-type: none"> Stainless steel 1.4404 (ASTM 316L) 90°
Sealing	<ul style="list-style-type: none"> Silicone-free (max. 90°C (190°F)) Silicone (max. 200°C (390°F)) Silicone (max. 240°C (464°F))

Maximum allowed differential pressure

- TBD

Maximum air leakage

Tested at 400 Pa (1.6" WC) differential pressure.

- 0.1% of nominal airflow with non-silicone sealant with AquaSeal
- 0.1% of nominal airflow with silicone sealant with AquaSeal
- 2% of nominal airflow with non-silicone sealant (without AquaSeal)
- 5% of nominal airflow with silicone sealant (without AquaSeal)



NOTE: Model Z's leakage level is higher than 1% without glue in the foldings.

Maximum water leakage

0 ml water leakage when applied with Aquaseal. Test is conducted for 20min at 40mm water pillar (400Pa). During that time no leakage is allowed. Leakage limit is for single cube or multimodule exchanger/ plate sizes.

4. COUNTER FLOW HEAT EXCHANGERS

4.1 Product Code Explanation

Product code example: MA0500x095-0600-030-2A00-2-0-0-0

M	A	0500x095	0600	030	2	A	00	2	0	0	0
1	2	3	4	5	6	7	8	9	10	11	12

Pos.		Configuration
1	Model	M
2	Plate material	A = Aluminum E = Epoxy coated aluminum
3	Heat exchanger size (AxB)	See sizes and plate distance table
4	Exchanger width (C)	Range depends on model
5	Nominal plate distance	Depending on plate size
6	Corner profile	2 = 90°
7	End plate	A = Plain endplate
8	Additional options	OO = Standard product CI = As per drawing
9	Sealing	5 = Silicone free (max 90°C (190°F)) 7 = Silicone (max 200°C (390°F))
10	Modules	0 = Single module exchanger 4 = Exchanger in multifunction casing
11	Airflow configuration	0 = L + L 2 = U + U 2 = L + U
12	Casing	0 = Standard 4 = Lean

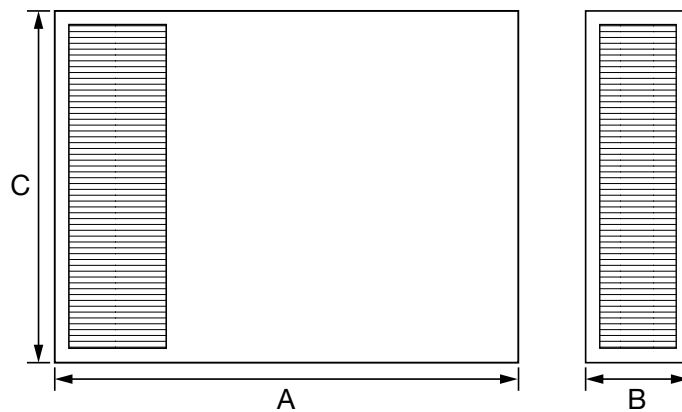

4.2 Model M

Sizes & plate distance

Model	A (mm)*	B (mm)	C (mm)	Plate distance
200 - 500 x 95	200 - 500	95	100 - 600	3.0 / 4.5 / 6.0
300 - 600 x 140	300 - 600	140	100 - 600	3.0 / 4.5 / 6.0
400 - 1000 x 190	400 - 1000	190	100 - 600	3.0 / 4.5 / 6.0 / 7.5
500 - 1000 x 235	500 - 1000	235	100 - 700	3.0 / 4.5 / 6.0 / 7.5

Image 9. *Available in 100 mm increments.

Components

Component	Material
Plates	<ul style="list-style-type: none"> Aluminum Epoxy coated aluminum
Casing	<ul style="list-style-type: none"> Aluzinc
Sealing	<ul style="list-style-type: none"> Silicone-free (max. 90°C (190°F)) Silicone (max 200°C (390°F))

Maximum allowed differential pressure

- 700 Pa (2.81" WC)

Maximum air leakage

Tested at 400 Pa (1.6" WC) differential pressure.

- 0.1 % of nominal airflow at 400 Pa (1.6" WC)

Maximum water leakage

Model M heat exchangers can be tightness tested with water. With lacquering as an option, the allowed leakage is less than 10 ml water during 3 min testing at 250 Pa differential pressure (1" WC). Without lacquering option, no specific tightness level can be guaranteed.

5. OPTIONS

5.1 Components

5.1.1 Plate material

Heatex offers three types of plate material (heat transfer surface). Aluminum for standard applications, epoxy-coated aluminum in more harsh environments, and stainless steel in heavy-duty industrial applications.

5.1.2 End plates & corner profiles

End Plate

An end plate is a part of the casing on a cross flow heat exchanger. There is one end plate on each side of the plate package. “A” is a flat metal sheet, “C” is single folded (L- shaped) and type “E” has a double folded edge (U-shaped).

Corner Profile

The profile is the corner piece, placed on the same sides as the inlets- and outlets- of the cross flow heat exchanger. Together with the end plates, the profile creates the frame around the heat transfer plates.

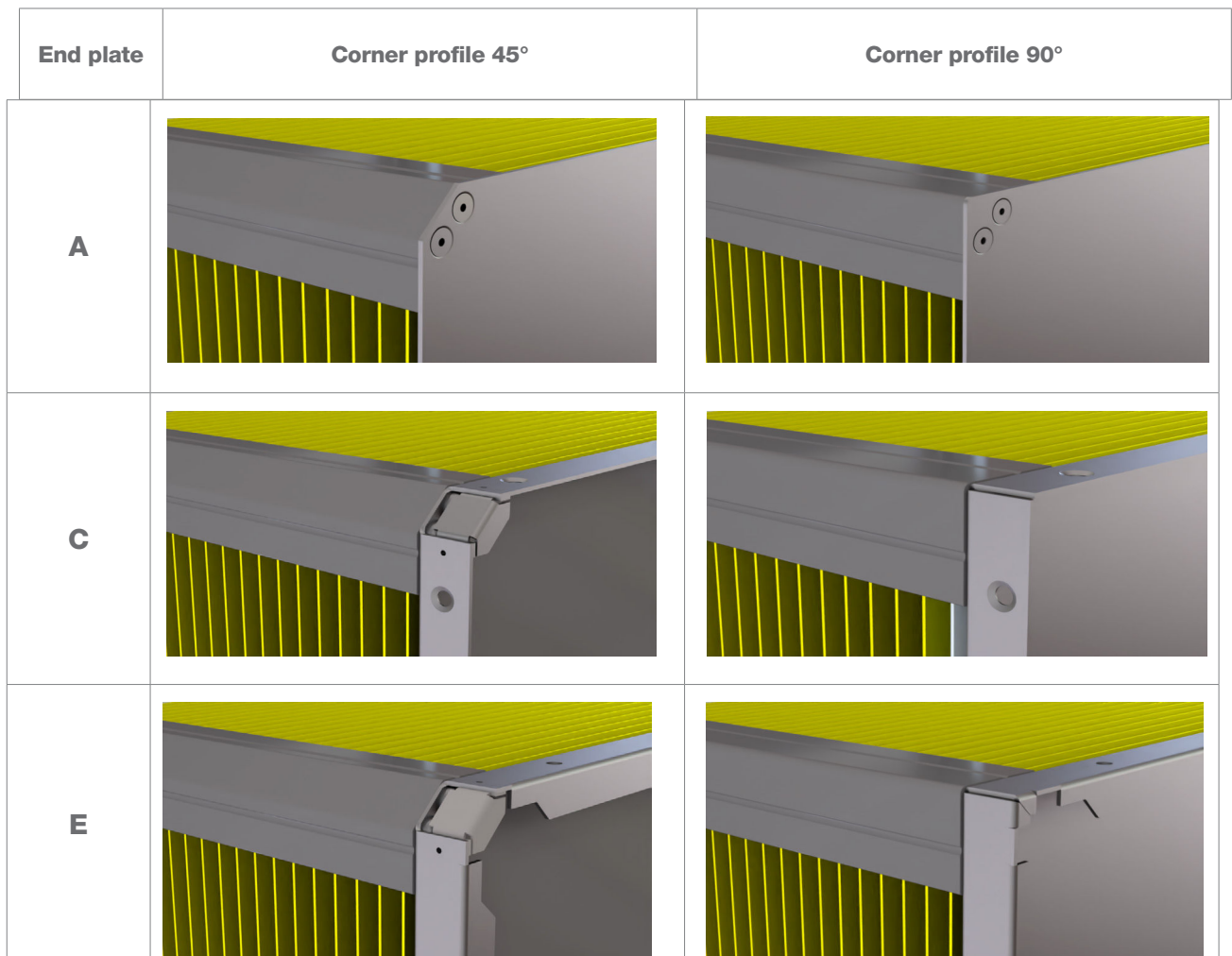

Image 10. End plates and corner profiles

5.1.3 Sealing

Plate folds

The purpose of the plate fold is to give strength to the plate package and to seal the two circuits.

Hotmelt

Hotmelt is applied in the fold as a sealing/glue. Below picture show a fold of two plates with Hotmelt applied.

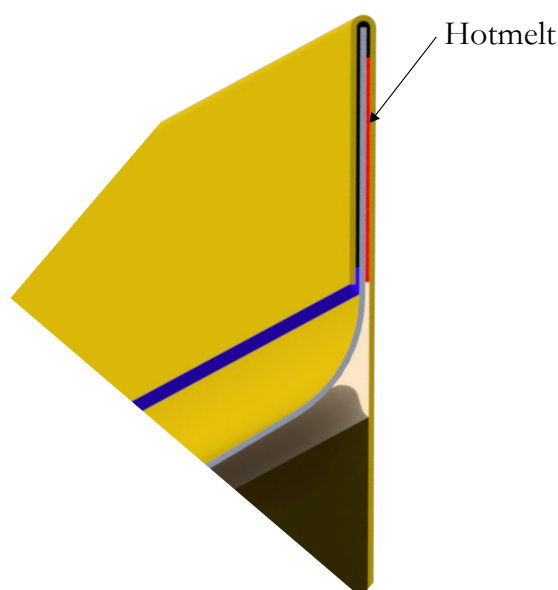

Image 11. Plate folds & hotmelt

Plate Corners

Standard sealant material on all aluminum (and epoxy-coated aluminum) heat exchangers is silicone-free and used for air temperatures up to 90°C (190°F). For higher air temperatures, other silicone-based sealants should be applied. Silicone-based sealant should not be used in paint/ spray booths or electronic cooling applications.

Physical & Chemical Properties

Sealant

Material:	MS-hybrid polymer, silicone-free (max. 90°C)	Acetic curing 1-component silicone (max. 200°C)	Industrial silicone (max. 240 °C)
Colors:	Grey	Translucent	Red
Contains fungicide:	No	No	No
Consistency	Paste, thixotropic	Paste, thixotropic	Paste
Specific gravity:	Approx. 1.50 kg/liter (12.52 lb/gal)	Approx. 1.04 kg/liter (8.68 lb/gal)	Approx.1.04 kg/liter (8.68 lb/gal)
Temperature limits	-40 to 90°C	-50 to 200°C	-60 to 240°C

5.1.4 Corrosion Resistance Tests

Epoxy coated aluminum

Salt-mist environment (salt spray) ASTM B117 (NaCl 5% at 35°C (95°F))	500 Hrs, no changes on the coating
Hot-wet environment ASTM 2247 (100% r.h at 38°C (100°F))	Tested for 1500 Hrs, without any remarkable variation of coating.

5.2 Bypass & Dampers

Dampers are suitable for closed/ open bypass exchanger section with a cross-flow heat exchanger. Profiles and damper blades are made of aluminum. Driving wheels are made of PP plastic with fiberglass (suitable for temperatures between -40°C to 80°C).

Sizes

- Frame height: 115 mm
- Blade width/ division: 100 mm
- Square shaft: 12 x 12 mm, 50 - 200 mm in length (part of the shaft that sticks out)
- Round shaft: 12 mm, 120 mm in length (part of the shaft that sticks out)
- Maximum damper width: 2500 mm (incl. bypass)
- Maximum damper-unit area: 4 m² (incl. bypass)
- Maximum blade length: 1300 mm

Tightness classification 2 according to EN1751.

Required torque

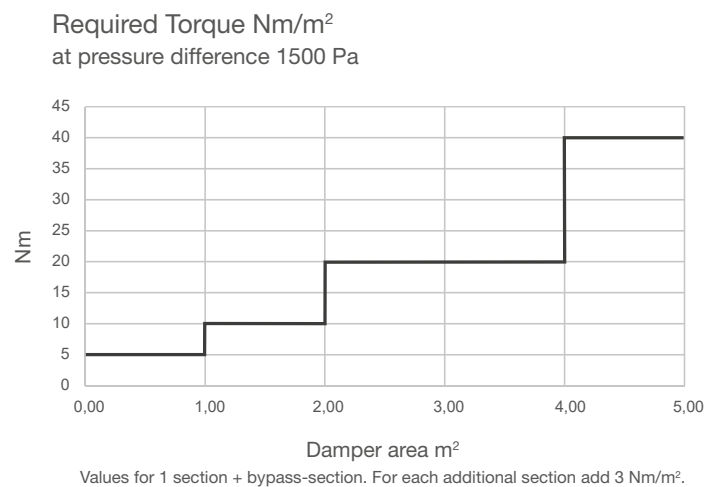

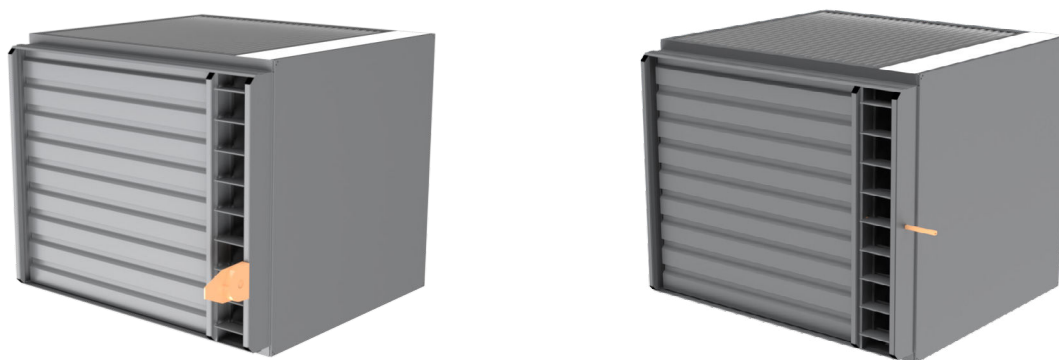

Image 12. Cross flow heat exchangers with bypass and damper. Left with adapter for damper motor (motor not included). Right, shaft for damper motor.

5.3 Damper Product Code

Pos.		Configuration
1	Model	A = Standard S = Internal one blade D = According to drawing
2	Material	A = Aluminum B = Corrosion protected G = Aluzinc
3	Outer Dimensions (LxW) mm	-
4	Bypass	S = Bypass on the side M = Center bypass E = Bypass damper U = No bypass D = Bypass
5	Bypass width (mm)	-
6	Damper blade orientation	L = Lengthwise T = Crosswise
7	Drive position	B = Bypass side V = Heat exchanger side M = Mid mounted U = Upward N = Downward
8	Type of drive	S = Square R = Round I = No shaft M = Motor holder
9	Shaft extension (mm)	-
10	Recirculation damper orientation	0 = No recirculation damper U = Left N = Right

6. ADDITIONAL OPTIONS

6.1 Further protection and tests

6.1.1 AquaSeal

Heatex offers AquaSeal, a process used to fill all plate crevices with a special polymer for water tightness and an even higher level of air tightness. This will result in a highly tight heat exchanger, suitable for applications with high humidity or direct water, such as adiabatic cooling and swimming pool applications. However, the level of tightness is only guaranteed if “individual air/water tightness test” is selected under options.

AquaSeal only applies to exchangers with plate spacing >3mm (0.12”). Heatex has confirmed that a max. temperature of 150°C during stable operating conditions is the upper limit. An individual evaluation is required for applications with large temperature fluctuations.

6.1.2 Lacquered plate edges

Is an option provided by Heatex to seal the cut edges of the heat exchanger plates, that are coated with epoxy coating. This is a way to protect the aluminum edges to maintain corrosion protection.

6.1.3 Corrosion protected framework

Heatex has two methods to increase corrosion protection, e.g., in wet and humid or industrial applications. For models H2, H, and P, a zinc-magnesium-coated steel end plates (ZM310) is used together with polyester powder-coated profiles. Also, bypasses are constructed with ZM310. The powder coating is grey and has a max allowed temperature of 90°C. For model M and dampers, the complete framework is powder-coated.

6.1.4 Individual air tightness test + report

The differential pressure during an air tightness test is set to 400 Pa. Leakage is set relative to the nominal flow.

6.1.5 Individual water tightness test + report

A water tightness test is performed at 400Pa (1.6” WC) for 20 minutes. The exchanger is tested on all four sides.

6.1.6 ATEX test

Heatex suggest using an aluminum plate heat exchanger in ATEX environment. The aluminum material, non coated, allow for low electrical resistance; thus, any static electricity due to the airflow is removed via the material. Heatex has also established a test protocol for plate heat exchangers to ensure low resistance between plates and end plates to minimize the risk of static electricity building up.

The recommended product options are aluminium plates, aluzinc end plates (excl. Model Z) and the established test procedure with protocol. Due to the insulating properties of the epoxy Heatex do not recommend epoxy coated aluminum plates.

7. TYPICAL APPLICATION CONFIGURATIONS

Below table show some example of applications and the product configurations.

Application	Model	Plate material	End plate	Corner profile	Sealing	Test	Options
Ventilation	H2	Aluminum	Aluzinc	Aluminum	Silicone free	None	Bypass and damper for freeze protection
Data center (Adiabatic cooling)	H2	Multilayer epoxy	Zn-Mg-coated steel	Powder coated aluminium	Silicone free + AquaSeal	Individual tightness test + report	Lacquered plate edges
Industrial heat recovery	H	Epoxy	Zn-Mg-coated steel	Powder coated aluminium	Silicone + AquaSeal	None	Lacquered plate edges
High pollution applications	Z	Stainless steel	Stainless Steel	Stainless Steel	High temperature silicone	None	None



NOTE! Silicone sealing may never be used in connection with paint spray booths or with cooling of electronics because it might cause damage to components in the vented area.

8. DEFINITIONS & FUNDAMENTALS

8.1 Terms

Term	Description
Airflow	Airflows are given as Nm ³ /h or m ³ /h or per minute or per second. The “N” stands for normal and refers to the normal conditions of 1 bar (1 atm) and 20°C (68°F).
Exhaust air	The exhaust air consists of the hot air coming from indoor or process. It is used to pre-heat and replace the supply air coming from outside.
Supply air	Supply air consists of fresh air, primarily the cold air stream, that is heated and replaces the exhaust air in a building or a process.
Relative humidity	Relative humidity is the amount of water the air contains in relation to the maximum possible at the actual temperature and pressure. Presented in %.
Absolute humidity	Moisture content is the amount of water the air carries in absolute terms. That is kg or pounds of water per kg or pounds of dry air. The maximum possible amount of water will vary with the air temperature. Presented in kg/kg, g/kg, lb/lb or gr/lb.
Efficiency or effectiveness	<p>Temperature efficiency of the heat exchanger.</p> <p>One of the most important ways to measure how well a heat exchanger performs is to look at the temperature efficiency of the exchanger.</p> <p>The efficiency on the hot side of the exchanger is defined as:</p> $\eta = \frac{t_{h, in} - t_{h, out}}{t_{h, in} - t_{c, in}}$ <p>The efficiency on the cold side of the exchanger is defined as:</p> $\eta = \frac{t_{c, out} - t_{c, in}}{t_{h, in} - t_{c, in}}$ <p> η – efficiency t – temperature (°C) c – cold side h – hot side in – into the exchanger out – out from the exchanger </p> <p>When the fluid flow rate (actually the mass flow multiplied with the specific heat) are equal on both sides the efficiency will also be equal on both sides.</p> <p>As you can see the efficiency tells you, how much of the maximum available temperature difference (the denominator) you can utilize in the heat exchanger.</p> <p>There are different efficiencies presented in Heatex software:</p> <ul style="list-style-type: none"> • η_{wet} is considering the actual temperature changes including impact from condensation. • η_{dry} is ignoring the impact from condensation. • η_{erp} is calculated according to EU Ecodesign regulation; same mass flow on both sides (supply mass flow is by default used), supply 5°C/0%RH and exhaust 25°C/0%RH.
Pressure drop	The pressure drop is the friction between the fluid and the wall surface in the heat exchanger and must be overcome by using a fan or a pump to force the fluid through the exchanger channels. Usually, the pressure drop is given in Pa or inches water column.

Term	Description
Transferred power	<p>When the temperatures or efficiencies and the flows are known it is easy to calculate the amount of heat that is transferred from the hot to the cold side. On the hot side the amount of heat is:</p> $q_{hot} = \rho \dot{V} c_p (t_{h,in} - t_{h,out})$ <p><i>Calculation of transferred heat</i></p> <p>q – is the amount of heat transferred (W) V – is air volume flow (m³/s) ρ – is fluid density (kg/m³) c_p – is specific heat of fluid (J/kg°C) t – is temperature (°C).</p> <p>The same relation is valid for the cold side and they must also be equal since no heat is created or disappears.</p> $q_{cold} = \rho \dot{V} c_p (t_{c,in} - t_{c,out})$ <p><i>Calculation of transferred heat</i></p>

8.2 Pressure Drop and Differential Pressure

In Heatex technical documentation and selection software Heatex use the term pressure drop and differential pressure. The difference is important since it can impact the design and function of the heat exchanger. Pressure drop (or pressure loss) is a decrease in static pressure in a component e.g. a heat exchanger. It is thus the difference in static pressure for a specific air stream inlet vs outlet. Differential pressure (pressure difference) is the difference in static pressure between two points in a system. For heat exchangers Heatex use it to define the pressure difference between e.g. exhaust inlet and supply outlet. Such an input of differential pressure can impact the pressure drop or leakage levels. The highest differential pressure, of the four possible, should be considered during selection.

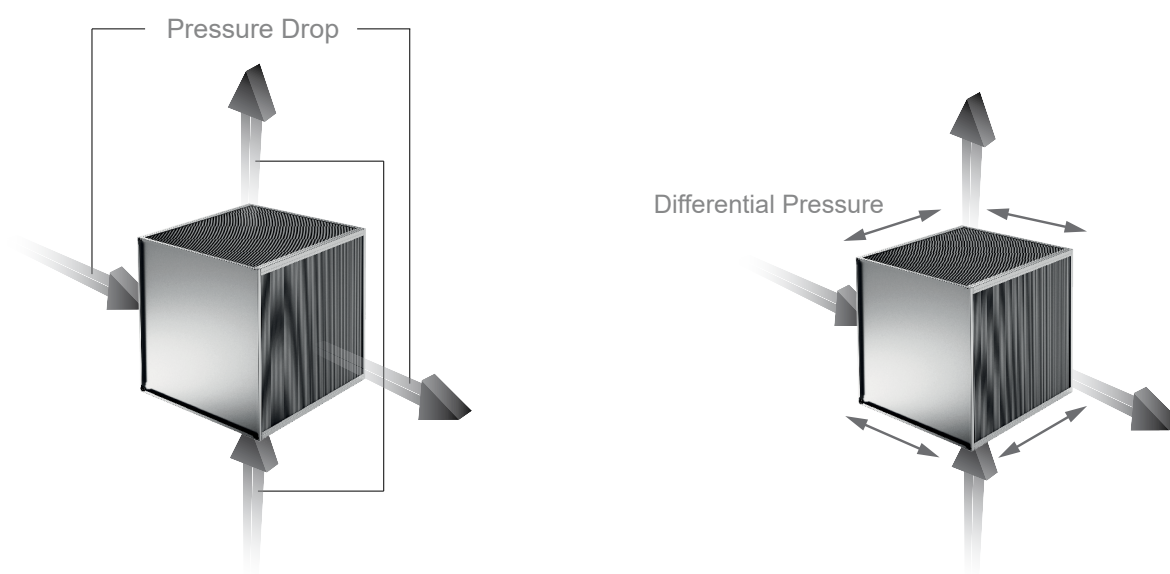

Example 1:

The exhaust side has a fan that sucks air through the heat exchanger, and the pressure entering the heat exchanger is -400 Pa (compared to atmospheric pressure). The pressure drop in the heat exchanger is 320 Pa, so the pressure at the exhaust exit side is -720 Pa ($-400-320$).

On the supply side, there is a fan before the heat exchanger pressing the air through the exchanger. Pressure at the inlet on the supply side is $+840$ Pa, and the pressure drop in the heat exchanger is 265 Pa, so on the supply exit side, the pressure is $+575$ Pa ($840-265$).

The maximum pressure difference at steady state and with both fans running is, in this case, 1560 Pa ($+840-(-720)$). Please observe that at zero flow, the fans will deliver a pressure much higher than at the design point. If the fans are allowed to start against closed dampers, the heat exchanger may be subjected to high enough pressures to cause permanent damage to the heat exchanger.

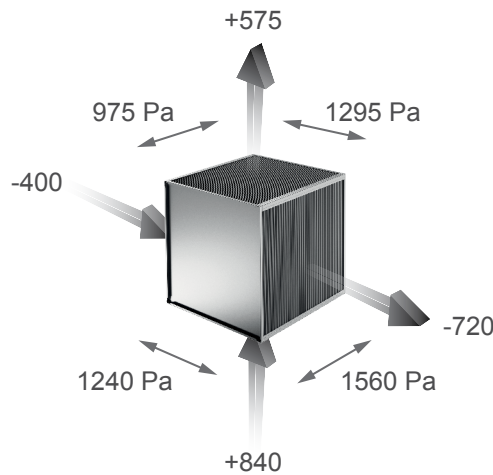

Example 2:

In the following example, both the exhaust and supply side have fans that suck the air through the exchanger: The exhaust side pressure entering the heat exchanger is -400 Pa (compared to atmospheric pressure). The pressure drop in the heat exchanger is 320 Pa, so the pressure at the exhaust exit side is -720 Pa ($-400-320$).

On the supply side, the pressure at the inlet on the supply side is -260 Pa, and the pressure drop in the heat exchanger is 265 Pa, so on the supply exit side, the pressure is -525 Pa ($-260-265$).

The maximum pressure difference at steady state and with both fans running is now 460 Pa ($-260-(-720)$), but with only the exhaust fan running, the maximum pressure difference is 720 Pa ($0-720$) compared to the ambient pressure.

The same comment as in Example 1 about starting fans against closed dampers is also valid here. Still, the maximum peak pressure difference value will be higher with one sucking and one fan pressing air through the heat exchanger compared to two sucking (or two fans pressing) air through the exchanger.

All pressure differences across the heat exchanger plates will cause the channels to deform. Minor pressure differences of a few hundred Pascal's will hardly be measurable, but at higher pressure differences, the channel with the relatively higher pressure will expand (pressure drop will decrease), and the channel with the lower pressure will contract (pressure drop will increase).

If differential pressure is not entered, the calculated pressure drop values in the heat exchanger are always presented at zero pressure difference. This is per the European norm EN 308 and its subdocuments which state that pressure difference shall be zero and that velocity and temperature profiles entering the heat exchanger shall be uniform. However, in Heatex Select, the effect of pressure differences can be calculated if a differential pressure is entered.

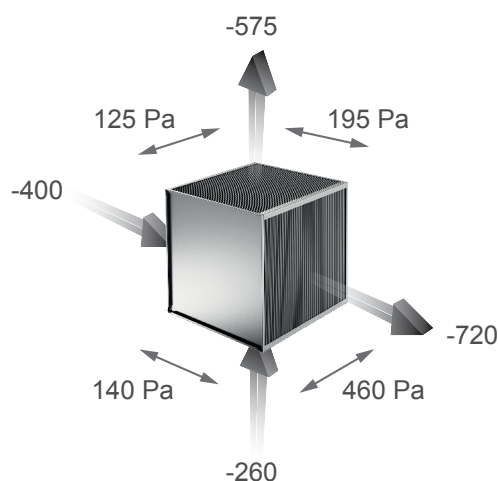

8.3 Influence of Pressure Differential on Pressure Drop

The pressure drop in a heat exchanger channel mainly depends on the channel's air velocity and geometry. If the plates (channel walls) in the heat exchanger are submitted to a differential pressure (i.e., the pressure is different in the exhaust and supply channels), then the plates will deflect. The amount of deflection will depend on plate material and material thickness, plate design, how the plates are supported against each other, and of course, on the magnitude of the differential pressure. When there is enough pressure difference for the plates to deflect, one channel will be narrower, and thus the pressure drop in that channel will increase, and the other channel will be wider with a lower pressure drop as a result.

For normal applications with around 200 Pa (0.8" WC) differential pressure, the effect appears to be only a few percent and does not necessarily need any further adjustments. However, the calculated pressure drops should be adjusted at high differential pressures. Heatex Select can simulate the effect of differential pressure.