

HEATEX

ROTARY HEAT EXCHANGERS



TECHNICAL INFORMATION

AIR-TO-AIR HEAT EXCHANGERS

HEATEX

ADDRESS AND CONTACT DATA

Heatex AB
Hyllie Boulevard 34
213 75 MALMÖ
Sweden
Telephone: +46 410 710 500

info@heatex.com

www.heatex.com

DISCLAIMER

Information in this document (including URL references and information from other external sources referred herein) is subject to change without notice. Owing to continued product development, Heatex reserves the right to introduce alterations in both design and prices without prior notice.

THIS DOCUMENT IS PROVIDED "AS IS" WITH NO EXPRESSED OR IMPLIED WARRANTIES WHATSOEVER, INCLUDING ANY WARRANTY OF MERCHANTABILITY, NON-INFRINGEMENT, FITNESS FOR ANY PARTICULAR PURPOSE, OR OTHERWISE ANY WARRANTY ARISING OUT OF ANY PROPOSAL, SPECIFICATION OR SAMPLE. ALL LIABILITY, INCLUDING LIABILITY FOR INFRINGEMENT OF ANY PROPRIETARY RIGHTS, RELATING TO USE OF INFORMATION CONTAINED OR REFERENCED IN THIS DOCUMENT IS HEREBY EXPRESSLY DISCLAIMED.

COPYRIGHT NOTICE

All information and content included (whether directly or by reference) in this document, such as text, graphics and images, is the property of Heatex AB, its subsidiaries, affiliates, licensors and/or joint venture partners. All rights are reserved.

No licenses, express, implied or otherwise to any intellectual property rights in this document are granted by Heatex AB.

This disclaimer and copyright notice is subject to and governed by Swedish law.

Copyright © 2025

Heatex AB

CONTENT

1.	HEATEX INTRODUCTION	6
2.	GENERAL INFORMATION - ROTARY HEAT EXCHANGERS	6
2.1	Product Selection with Heatex Select	6
2.2	Performance Results	7
2.3	Matrix Material	8
2.3.1	Aluminum (Condensation)	8
2.3.2	Hybrid with Silica Gel or Molecular Sieve (Enthalpy)	8
2.3.3	Silica Gel (Adsorption)	8
2.3.4	Molecular Sieve Coated (Adsorption)	8
2.4	Well Height	10
2.5	Temperature	10
2.5.1	Condensation	10
2.5.2	Freezing	11
2.5.3	Corrosion	11
2.6	Fan Positioning	11
2.7	Plane of Intersection	12
2.8	Leakages	13
2.8.1	Seals	14
2.8.2	Purge Sector	15
2.8.3	Purge Sector Location	16
2.9	Hygienic Requirements	17
3.	DISPOSAL	18
3.1	Matrix Material	18
3.2	Casing Material	18
3.3	Electrical Components	18
3.4	Other Components	18
4.	MODEL EN, O & ER (WHEELS WITHOUT CASING)	19
4.1	Model Descriptions	19
4.1.1	AHU Design Requirements	19
4.2	Model EN	20
4.2.1	Dimensions	20
4.2.2	Matrix Material & Well Heights	20
4.2.3	Exchanger Orientation	20
4.2.4	Hub	20
4.2.5	Application Limits	20
4.3	Model O	22
4.3.1	Dimensions	22
4.3.2	Matrix Material & Well Heights	22
4.3.3	Exchanger Orientation	22

4.3.4	Hub	22
4.3.5	Application Limits	23
4.4	Model ER	24
4.4.1	Dimensions	24
4.4.2	Matrix Material & Well Heights	24
4.4.3	Exchanger Orientation	24
4.4.4	Hub	24
4.4.5	Wheel Design	25
4.4.6	Delivery Options	26
4.4.7	Application Limits	27
5.	MODEL E & MODEL ES (WHEELS WITH CASING)	28
5.1	Model E Description	28
5.1.1	AHU Design Requirements	29
5.1.2	Dimensions	31
5.1.3	Matrix Material & Well Heights	32
5.1.4	Seal	32
5.1.5	Exchanger Orientation	33
5.1.6	Hub	33
5.1.7	Purge Sector	33
5.1.8	Drive Equipment	33
5.1.9	Drive Location	36
5.1.10	Drive Belt	36
5.1.11	Application Limits	36
5.2	Model ES Description	38
5.2.1	AHU Design Requirements	39
5.2.2	Dimensions	40
5.2.3	Matrix Material & Well Heights	41
5.2.4	Seal	41
5.2.5	Exchanger Orientation	42
5.2.6	Hub	42
5.2.7	Purge Sector	42
5.2.8	Drive Equipment	42
5.2.9	Drive Location	44
5.2.10	Drive Belt	44
5.2.11	Application Limits	44
5.2.12	Delivery Options	45
6.	CASING OPTIONS	46
6.1	Corrosion Protected Framework	46
6.2	Inspection Hatches	46
6.3	Cable Glands	46
6.4	Covered Casing	46
6.5	Condensation Tray	46

6.6 Casing Dimensions	47
6.6.1 Standard	47
6.6.2 Custom	47
7. NOTES	47
7.1 ATEX	47
8. DEFINITIONS AND FUNDAMENTALS	48
8.1 Definition Description	48

1. HEATEX INTRODUCTION

Heatex is specialized in air-to-air heat exchangers and was founded in 1987 in Sweden. Since then, the company has grown and has a global presence with production in Europe, the USA, and China and a worldwide sales force. The product portfolio covers rotary and plate heat exchangers primarily with aluminum (or coated) heat transfer surfaces.

Our products follow the most relevant standards, and our selection software is certified according to Eurovent, TÜV, and AHRI certification programs for air-to-air heat exchangers. This includes yearly performance tests at an independent laboratory. Read more at heatex.com.

Warranty terms are only valid as long as original parts are used and the rotor is secured to the AHU according to the instructions in the "Installation and Maintenance Manual."

2. GENERAL INFORMATION - ROTARY HEAT EXCHANGERS

2.1 Product Selection with Heatex Select

Product selection and performance calculations are made using our selection software, Heatex Select, which is always available and up to date at heatex.com.

All heat transfer and pressure drop calculations are done with the actual heat exchanger geometry. They are based on sources such as VDI Wärmeatlas and the International Handbook of Heat Exchanger Design.

The calculations follow the European norm EN 308 and its subdocuments. For accurate calculations, the parameters in Figure 1 below should be known.

<p>Supply air:</p> <ul style="list-style-type: none"> • Airflow (either at standard air conditions that is 101325 hPa (406.78" WC) and 20 °C (68°F) or else the temperature at which the airflow is given must be stated). • Air temperature • Relative humidity of the air (Heatex Select includes a wet bulb, abs. humidity to rel. humidity converter).
<p>Exhaust air:</p> <ul style="list-style-type: none"> • Airflow (either at standard air conditions that is 101325 hPa (406.78" WC) and 20 °C (68 °F) or else the temperature at which the airflow is given must be stated). • Air temperature • Relative humidity of the air (Heatex Select includes a wet bulb, abs. humidity to rel. humidity converter).
<p>Required performance:</p> <ul style="list-style-type: none"> • Expected efficiency or transferred power. • Maximum allowed pressure drop in the heat exchanger. • Maximum allowed leakage
<p>Restrictions regarding dimensions:</p> <ul style="list-style-type: none"> • Since space often is limited, the maximum allowed rotor casing size (width, height and depth) should be considered.

2.2 Performance Results

Key result parameters for rotor heat exchanger in ventilation applications are the pressure drop and efficiency. Pressure drop is presented as two values: real/actual which represent pressure drop for the actual flow rates and temperatures. The second value is the pressure drop when adjusted to 1.2kg/m³.

Other relevant parameters are:

- Face velocity which is the velocity onto the matrix surface. In ventilation applications the velocity is normally in the range of 1-3m/s. Lower velocity could impact distribution of air and higher velocity could cause a too high pressure drop.
- Transferred power is the energy recovered in the RHE. It includes both sensible and latent energy.
- Condensate is the predicted amount of water that will trickle down from the RHE. It comes from the condensation of the humidity in the hot and humid airflow.
- Energy efficiency and class is calculated according to EN 13053. It adjusts efficiency based on the pressure drop in the RHE.
- Erp efficiency is intended for European Ecodesign and should be above 73%.

There are several reasons for designing the AHU with a low pressure difference apart from the influence on performance. For example:

- Wear of sealant, bearings, drive system etc. will increase with high-pressure difference.
- Leakage will increase with high-pressure difference which apart from influence of performance will increase carry-over of odors and dirt to the clean side. The sealant is not designed for high pressure differences and will work much less efficient at high pressures.

Due to the above considerations, there is a limit to maximum pressure drop and pressure difference. See Model specifications.

Testing and certification of the RHE is done with uniform air velocity and temperatures over the entire heat exchanger surface. Thus, Heatex software is adapted to these conditions. Operating with uneven air velocity or temperatures over the heat exchanger will adversely affect both calculated efficiency and pressure drop. Uneven air distribution in the RHE can be caused by the following examples:

- Fans located close to the heat exchanger inlet.
- Fans located close to the heat exchanger outlet.
- Curved airflow before or after the heat exchanger.
- Heat exchanger inlets shadowed by sheeting or other components.

Other things to consider in the design of an AHU with an RHE are condensation and purge sector.

- A condensation tray might be necessary depending on the amount of condensate.
- A purge sector is impacting leakage in the RHE. A purge sector uses some of the supply air to avoid contamination from exhaust. This leads to a higher OACF but a lower EATR. These values can be found in the performance results section of Heatex Select. See chapter Leakage.

2.3 Matrix Material

There are five matrix material combinations also referred to as "heat transfer media" to choose from.

2.3.1 Aluminum (Condensation)

The main use for an aluminum matrix is the transfer of heat between the warm and the cold airflow. Moisture transfer will take place only if condensation occurs.

2.3.2 Hybrid with Silica Gel or Molecular Sieve (Enthalpy)

Hybrid materials consists of a corrugated aluminum foil combined with either a silica gel based coated flat aluminum foil or a molecular sieve based coated flat aluminum foil. The main use for a hybrid matrix is the enhanced moisture transfer compared to an aluminum matrix since moisture transfer will take place when the inlet moistures are different as well as when condensation occurs.

2.3.3 Silica Gel (Adsorption)

Both corrugated and flat foils are coated with a silica gel coating that offers a high humidity efficiency in all environments.



Silica Gel (Enthalpy and Adsorption) material is only available from Heatex China.

2.3.4 Molecular Sieve Coated (Adsorption)

Both corrugated and flat foils are coated with a molecular sieve 3Å coating that offers high humidity efficiency and protection against odors transferring from exhaust to supply air.

Molecular sieves (Synthetic Zeolite) adsorb moisture more strongly than silica gel. This can be seen by the high initial slope of the adsorption isotherm for the molecular sieve compared to the other desiccants (Figure 2). Where a very low relative humidity is required, molecular sieves are often the most economical because of their high adsorption capacity at low relative humidity (Figure 3). Also, as temperatures rise, molecular sieves will not give up moisture as readily as silica gel (Figure 4).

Molecular sieve contains a uniform network of crystalline pores and empty adsorption cavities, which give it an internal adsorptive surface area of 700 to 800 m²/g (½ the total volume of the crystals). Molecular sieves can absorb up to 25% of their weight in water.

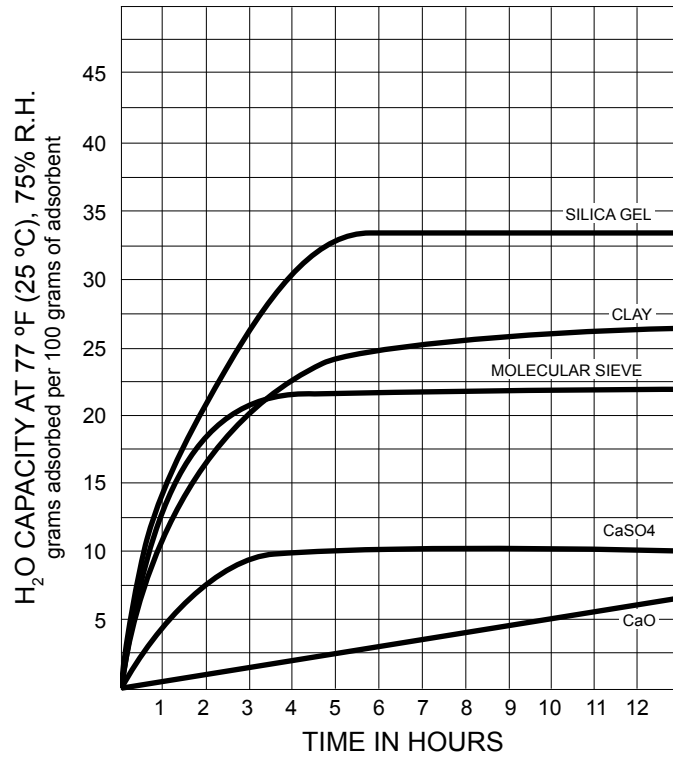

Image 1. Input parameters

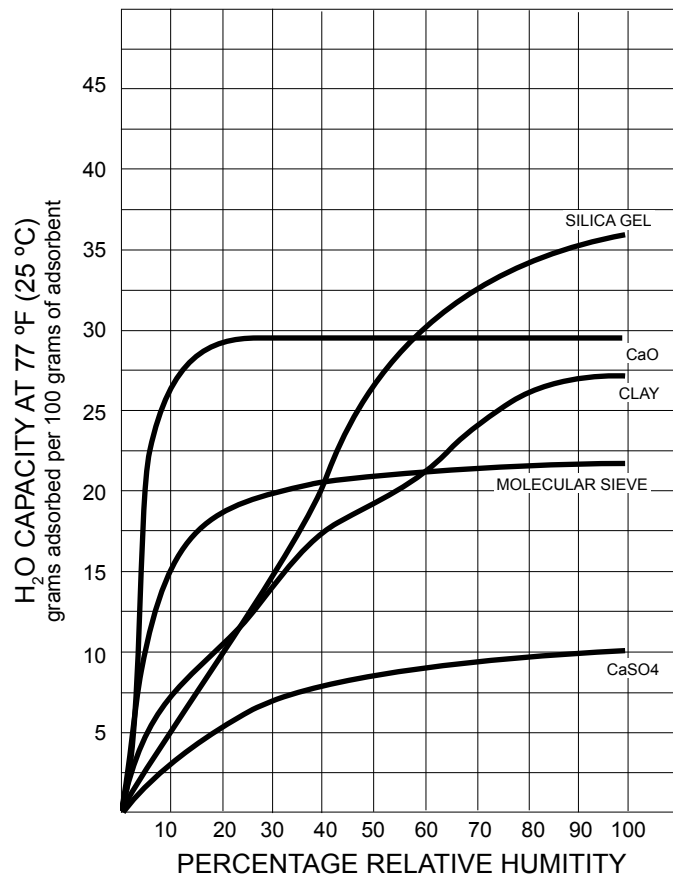

Image 2. Adsorption rate (H2O) of various adsorbents.

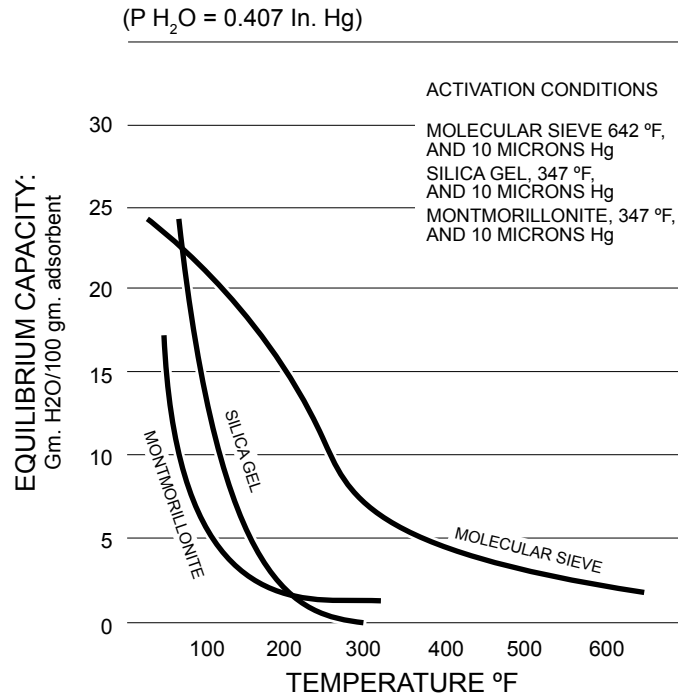

Image 3. Equilibrium capacity (H₂O) of various adsorbents.

2.4 Well Height

The well height definition is defined as flat foil thickness plus total wave height, see Figure below.

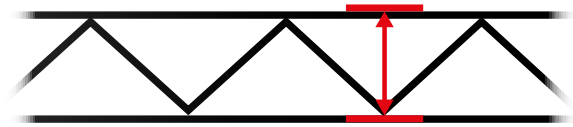

Image 4. Well height definition.

A low well height provides the highest efficiency and pressure drop. This is suitable for units with a high-efficiency demand or when airflow is low.

A high well height is a better match if the demand for efficiency is modest or the pressure drop must be low, like when a very high flow rate is specified.

2.5 Temperature

2.5.1 Condensation

Condensed water can block the channels leading to unexpected higher pressure drop. The following can be done to avoid condensation in the RHE:

- Reduce the humidity in the warm airflow (dehumidification) before entering the wheel.
- Select a larger well height which will lead to lower performance hence avoiding or reducing condensation

In cases where there is a lot of condensation in a condensing (aluminum or epoxy) RHE, it can occur that only some of the water that has condensed will be picked up by the supply air. In that case, “free water” will come out of the rotor, and a condensate tray for collecting the water should be installed.

2.5.2 Freezing

Freezing in an RHE only occurs if condensate is present. Severe freezing is uncommon in an RHE due to the wheel's rotation. Frost that appears in the cold air stream melts typically in the warm air stream. Freezing can, however, occur in certain circumstances. The freezing process depends on the condensate level and the air stream temperatures. Frost becomes a problem when it builds up faster than it melts. This process usually takes many hours. It is essential to be observant if the pressure drop increases during long periods of cold inlet temperatures. Frost building up in the matrix can cause high-pressure drops and severely damage the wheel.

Heatex Select includes a warning indicating if the conditions chosen could lead to freezing problems. The warning is based on field experience and the rule of thumb that the risk of freezing is higher if the average temperature of the two inlet air streams is below zero.

There are several methods to prevent frost accumulation:

- Preheating of the outdoor air in e.g. a heating coil. With a higher temperature, condensation can be avoided, and the average temperature is increased (above 0 °C) so that the risk of freezing decreases.
- By lowering the rotor speed the heat transfer efficiency will decrease. This is thus another way to avoid condensation and possible freezing.
- If bypassing the cold air stream or parts of it, it is possible for the warm side to melt any frost build up. Once the frost is gone, monitored by e.g. pressure drop measurement, the cold side bypass can be closed, and normal operation restarted.

2.5.3 Corrosion

Heatex standard casing material is galvanized steel. Depending on the geographical location or application, the RHE might need additional protection against corrosive environments. A corrosion-protected framework is available. See chapter "Options".

2.6 Fan Positioning

The recommended fan configuration is to have both fans on the heat exchanger's exit sides and always ensure that pressure is higher on the supply side than on the exhaust side. In this way, leakage will be from the fresh air side to the exhaust side, not affecting the indoor air quality.

Figure 7 below explains the different fan configurations pros and cons. Where;

- P11 = Static pressure at exhaust air inlet
- P12 = Static pressure at exhaust air outlet
- P21 = Static pressure at supply air inlet
- P22 = Static pressure at supply air outlet
- P22-P11 = Pressure differential house side
- P21-P12 = Pressure differential ambient side

To minimize leakage from the exhaust to the supply, the differential pressure on the house side should thus be positive. The ambient side's differential pressure will be even higher due to pressure drops. This is a criterion for the function of the purge sector.

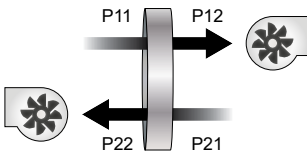
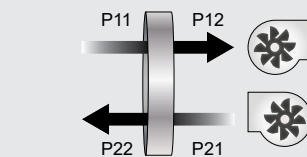
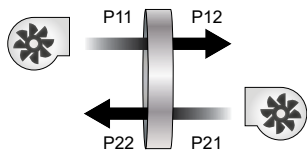
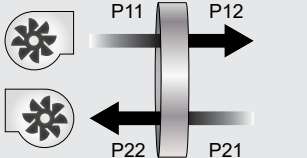
Fan location	Description
	<p>This combination has two pulling fans for the supply and exhaust airflows. If correctly adjusted, a proper pressure difference between the supply and exhaust air can be maintained, achieving relatively low EATR and OACF values. This is the recommended configuration.</p>
	<p>The exhaust air is pulled while the supply air is pushed through the air duct. This combination creates a high-pressure difference between the supply and exhaust airflow, leading to very low EATR but a higher OACF.</p>
	<p>This combination has two pushing fans for the supply and exhaust airflows. If correctly adjusted, a proper pressure difference between the supply and exhaust air can be maintained, achieving relatively low EATR and OACF values.</p>
	<p>In this arrangement, the supply air is pulled, and the exhaust air is pushed, leading to a higher pressure on the exhaust air duct, causing a high EATR and low OACF. If exhaust air contamination is not an issue, this might be a good combination since it keeps the OACF low, but in general, this is not a recommended configuration in ventilation installations.</p>

2.7 Plane of Intersection

The plane of intersection impacts the airflow arrangement in the AHU. There are two rotor arrangements, top to bottom and side to side.

- Top/ bottom: The duct separation (beam) is horizontal across the heat exchanger. The airflows are on the top/ bottom side of the beam. It is sometimes referred to as upper/lower deck flow configuration. (Left figure below)
- Side to side: The duct separation (beam) is vertical across the heat exchanger. Where the airflows are on the right and left sides of the separation. (Right figure below)

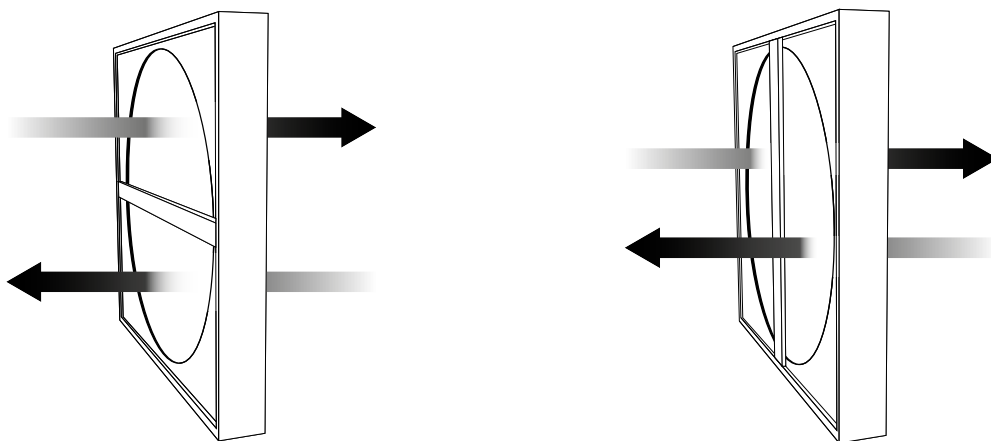

Image 5. Top/ bottom air flow arrangement (left) and side to side airflow arrangement (right).

2.8 Leakages

There are two kinds of leakages: internal and external. External leakage is the leakage from the rotary heat exchanger to the surroundings. To reduce this leakage, seals are placed on the diameter of the wheel and tied to the cover plate so that the airflow will go through the wheel. Internal leakages are considered to be the leakages within the rotary heat exchanger. There are two important definitions of internal leakages: EATR and OACF.

EATR is an abbreviation for Exhaust air transfer ratio. It represents the air mass leakage from exhaust air into the supply air. The main contributing factor to EATR is the carryover, a consequence of the wheel's rotation and, thus, the transport of the exhaust air trapped in the matrix. With the rotation of the wheel, the exhaust air enters the supply side. The EATR value is presented as the percentage (%) of exhaust air in the supply air.

Some ways to lower the EATR are:

- A purge sector is a way to minimize this carryover since some supply air is used to push out the exhaust air from the matrix before entering the supply side. The drawback is that extra supply air is needed to fulfill the supply air need for ventilation while some supply air is being used in the purge sector and thereby enters the exhaust side.
- EATR can also be minimized by using a pushing fan on the supply and a pulling fan on the exhaust. This will increase the pressure differential and minimize the amount of exhaust air going into the supply side. The drawback is the loss of supply air.
- Lowering the rotation speed of the wheel will lower the amount of exhaust air transported via the matrix. However, this will lower the efficiency.

OACF is an abbreviation for outdoor air correction factor. It shows how much air is lost in the heat recovery unit. The value is a ratio between the supply air inlet flow and supply air outlet flow. In ideal conditions, the ratio is one. A value of 1.1 means that 10% more supply airflow is needed to compensate for leakages within the heat exchanger. An OACF below one means exhaust air leaks into the supply side.

Leakages depend mainly on the pressure differential between the supply and exhaust side and the type of sealing used. Systems are often designed to have a higher operating pressure on the supply side to avoid leakage and contamination from exhaust air. The drawback with high differential pressure is leakage of supply air. Keeping the differential pressure at the lowest possible level minimizes supply air leakage and maintains an OACF close to one. Another way to reduce supply air leakage and maintain a low OACF is to use sealing, e.g., brush sealing. Internal sealing between the two air streams and on the outer rim of the rotor is important to minimize supply air leakage.

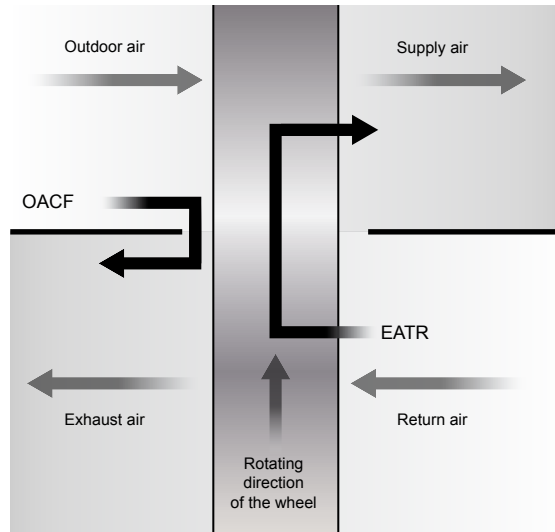

Image 6. Description of leakages

2.8.1 Seals

Perimeter seals

Seals are placed along the wheel's perimeter to prevent external leakage; see figure below.

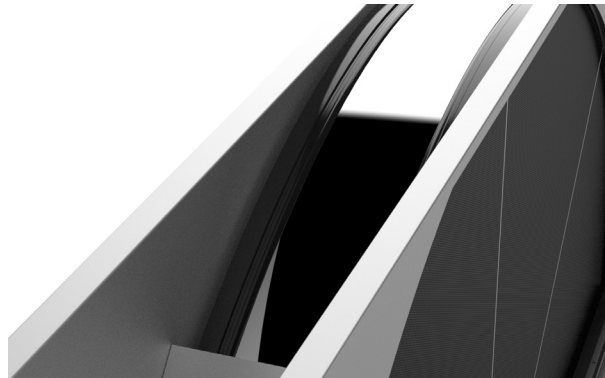

Image 7. Perimeter seals to prevent external leakage.

Middle beam seals

Seals are placed along the middle beam and across the purge sector to avoid internal leakage between the air channels. The seals are placed on both rotor sides; see the figure below.

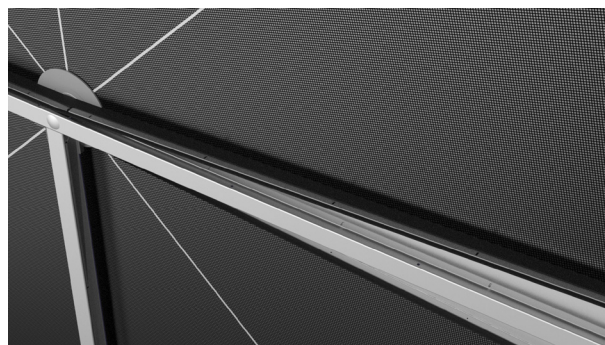

Image 8. Middle beam seals to prevent internal leakage.

2.8.2 Purge Sector

Due to the wheel's rotation, the purge sector minimizes the carry-over from the exhaust to the supply air. With well-adjusted brush sealants, a purge sector, a pressure difference of zero to +20 Pa (0.08" WC), and equal air mass flow, the amount of internal leakage ("carry-over") can be less than 3% of the airflow. For all other conditions, the internal and external leakage will be higher.

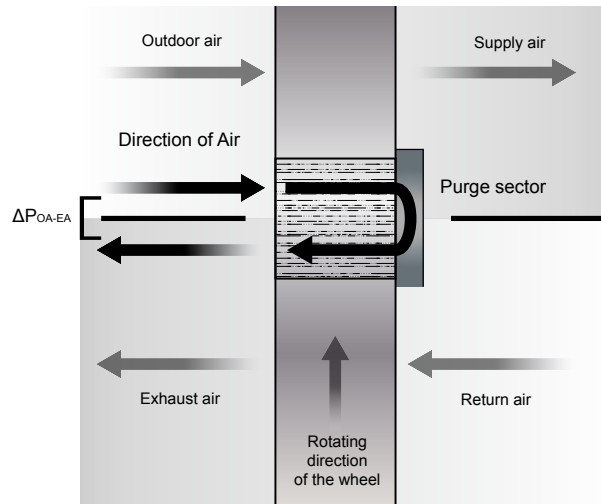

Image 9. Description of purge sector's function.

The purge sector covers 7-20 degrees (depending on the material of the matrix). For equal air flows and close to 0 Pa pressure difference, the purge airflow will be of the supply airflow. This means that for these conditions, the supply air before the rotor will be 1.4 % larger than after the rotor, and since this purge air flow will end up on the exhaust side, the exhaust air flow after the rotor will be 1.4 % larger than before the rotor.

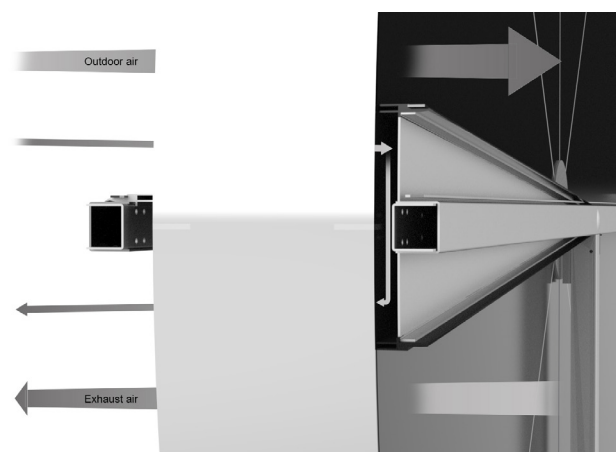



Image 10. Purge sector angle.

For the purge sector to work correctly, the pressure difference between supply air immediately before the rotor and exhaust air immediately after the rotor should be between 200 Pa (0.8" WC) and 500 Pa (2" WC) at expected airflows. Fans should, as always, preferably be on the exit side (sucking air through the RHE) for both airflows. If the exhaust fan is before the rotor and the supply fan is after the rotor, the purge sector will have a backflow, and, in that case, the purge section should be removed.

In Heatex Select, the airflows that participate in the heat and mass transfer should be used as input data (i.e., supply air leaving the rotor and exhaust air entering the rotor). The purge airflow does not affect the wheel's performance, but the calculation considers that 5 degrees (purge angle) of the total 360 degrees is used for the purge sector and does not participate in the heat and mass transfer.

Due to the wheel rotation, some air gets trapped inside the matrix during the rotation from one air duct to the other. The trapped air in the wheel is transferred and mixed with the following airflow. If the air transferred is exhaust air into the supply air, the result is the contamination of the supply air by a small amount of the exhaust air. This effect is called carry-over or Exhaust Air Transfer Ratio (EATR onwards) and is expressed in percentage (%) of the total airflow.

The purge sector is optimized to reduce the carryover or EATR. It stops the inlet of exhaust air in the small area right before the airflow switch, thus preventing exhaust air from getting trapped into the matrix. A small amount of supply air is used to blow out minor exhaust that might have been trapped to ensure fresh and clean supply air.

 **NOTE!** The purge sector needs a pressure difference (ΔP_{OA-EA}) between 200 Pa (0.8" WC) and 500 Pa (2" WC) to work properly. Please remember that pressure differences exceeding 600 Pa (2.4" WC) are not allowed.

2.8.3 Purge Sector Location

The location of the purge sector depends on the plane of intersection and the airflow configuration.

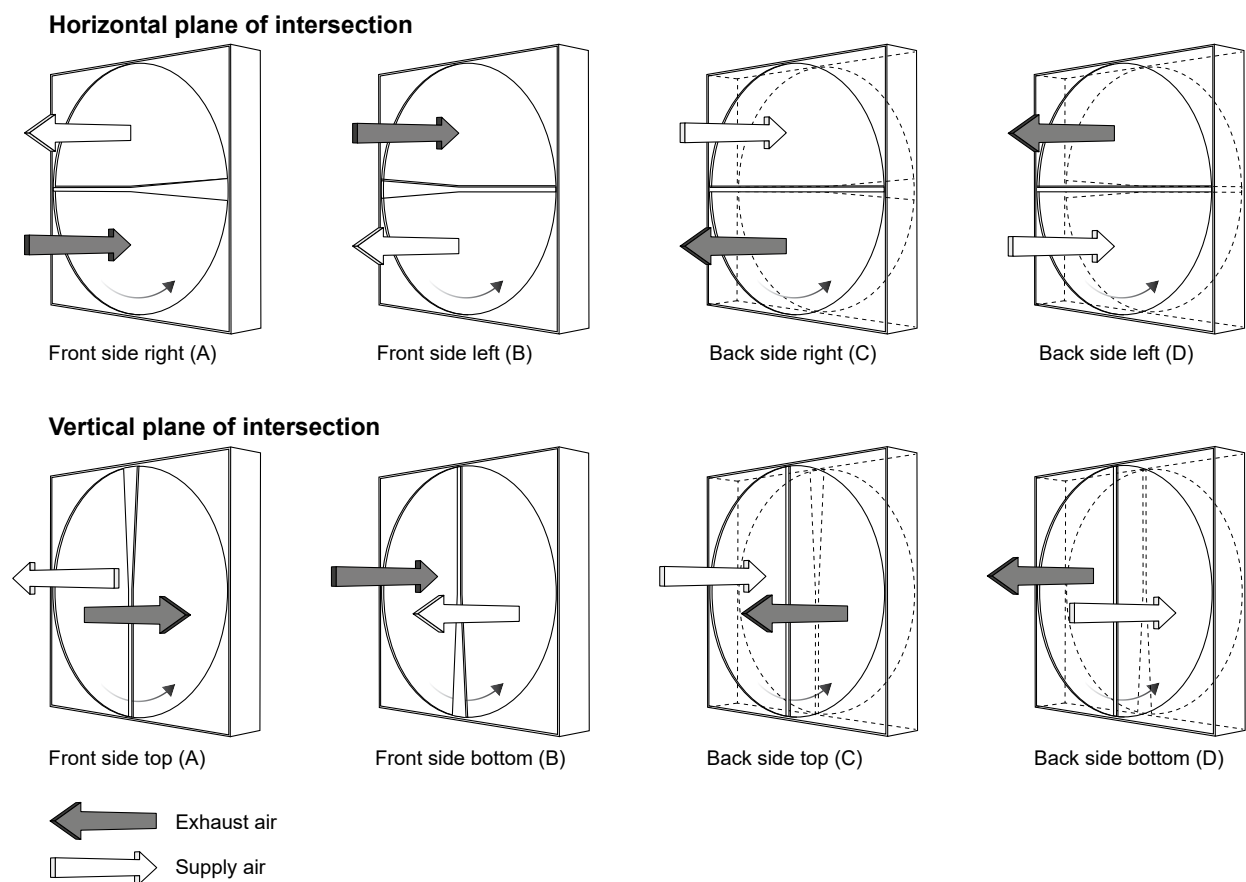

Image 11. Purge sector locations.

2.9 Hygienic Requirements

Conditions to fulfill hygiene certification requirements are:

- Purge sector is required in order to make sure that less carry-over than 3% is reached.
- The AHU needs to be designed with hatches or openings towards all four open sides of the rotary heat exchanger. The heat exchanger itself has all four sides open.
- All surfaces inside and outside of the rotor casing, especially the bottom surface and around the motor should be reachable for maintenance, cleaning and disinfection. Meaning that the openings or hatches mentioned in the item above need to be of sufficient size to fulfil the cleaning and disinfection requirements.
- The AHU needs to be designed in such a way that the rotary heat exchanger is possible to slide out for cleaning and disinfection.
- Cleaning and disinfection of the heat exchanger should be done in accordance with Heatex cleaning and disinfection instructions with the cleaning and disinfection substances prescribed by Heatex (See chapter "Maintenance").
- When condensation is present, the AHU installer needs to make sure that condensation trays are installed beneath the heat exchanger. These trays need regular inspection, cleaning and disinfection.
- The trays should be designed and installed with sufficient drainage in accordance with the hygiene standard VDI 6022, chapter 4.3.16.
- The heat exchangers are not certified for installation in exhaust classes ETA 3 and ETA 4 according to EN 13779 (09/2007).

For hygienic certified rotors, contact Heatex.

3. DISPOSAL

A rotary heat exchanger's weight consists of around:

- 50 % aluminum
- 45 % galvanized steel sheet metal
- 5 % other materials (electrical motor/controller, belt, brush seal, silicone, pop rivets, and screws).

The disposal of each component should be according to the regulations in the country where the product is dismantled.

3.1 Matrix Material

The wheel is, except for the center shaft and bearings, made of aluminum. The second or third letter of the product code explains the coating of the aluminum.

Example:

- EA/ESA/ENA = Aluminum, not coated
- EE/ESE/ENE = Epoxy coated aluminum (6 g/m² (0.18 oz/yd²))
- EM/ESM/ENM = Molecular sieve coated aluminum
- ED/ESD = Silica gel coated aluminum
- EK/ESK = Hybrid unit using aluminum coated with silica gel and non-coated aluminum.
- EL/ESL/ENL = Hybrid unit using aluminum coated with molecular sieve and non-coated aluminum.

Disposals are normally divided in two separate ways: Pure aluminum and coated aluminum. Local regulations may apply.

3.2 Casing Material

The casing should be treated as metal and therefore be properly disposed of according to regulations in each country.

3.3 Electrical Components

Motor, control, cables, and rotation detectors should be treated as electrical waste. Some electrical motors have a gearbox that contains up to 0.4 liters (13.5 fl oz) of mineral oil.

3.4 Other Components

Drive belts and brush seals are generally treated as combustible waste. Products from Heatex do not contain minerals known as "conflict minerals".



As rotary heat exchangers contain a lot of thin-cut metal, appropriate safety equipment should be used to secure the health of the personnel during the disposal procedure.

4. MODEL EN, O & ER (WHEELS WITHOUT CASING)

4.1 Model Descriptions

	O	A	0600	V	-	200	-	020	-	2	OO	-	0	220
Pos.	1	2	3	4		5		6		7	8		9	10

Pos.		Configuration	EN	O	ER
1	Model	EN = Undivided for low flowrates O = Undivided for mid flow rates ER = Divided for replacement high flowrates	EN - -	- O -	- - ER
2	Matrix material	A = Aluminum E = Epoxy K = Hybrid (with silica gel) L = Hybrid (with molecular sieve) D = Adsorption (silica gel) M = Adsorption (molecular sieve)	√ - √ √ - √	√ √ √ √ √ √	√ √ √ √ √ √
3	Rotor diameter	In mm	200-500	500-2575	1600-3800
4	Exchanger orientation	H = Horizontal V = Vertical	√ √	√ √	- √
5	Rotor depth	In mm	200, 100, 150	200	200
6	Well height	In mm	See table	See table	See table
7	Hub	2 = Bearing with shaft 4 = Bearing without shaft 5 = Fixed shaft without bearing 7 = Bearing with shaft, corrosion resistant.	√ - - -	√ √ - √	√ - √ √
8	Option	OO = Standard product CI = According to drawing	√ √	√ √	√ √
9	Spokes	1 = Without spokes	√	-	-
10	Shaft length	In mm	230	220	See info
11	Delivery Options	A = Two halves B = Segments C = Split segments	- - -	- - -	√ √ √

4.1.1 AHU Design Requirements

For all wheel only models the basic components are hub, shaft and matrix. Casing, motor, belt and sealings are not included. An AHU or casing is needed to provide structural support.

4.2 Model EN

Model EN is an unsegmented wheel only. Due to its small diameter and low loads, it does not include any spokes.

4.2.1 Dimensions

- Wheel diameter: 200-500mm. Available in increments of 1mm.
- Wheel depth: 200mm, 100 mm, 150 mm
- Shaft length: Wheel depth +30mm.
- Shaft diameter: 12mm.

4.2.2 Matrix Material & Well Heights

Aluminum/ Epoxy	Hybrid with Molecular Sieve	Molecular Sieve
1.4 mm (0.055")	1.4 mm (0.055")	-
1.6 mm (0.063")	1.6 mm (0.063")	1.6 mm (0.063")
1.8 mm (0.071")	1.8 mm (0.071")	1.8 mm (0.071")
2 mm (0.079")	2 mm (0.079")	2 mm (0.079")

4.2.3 Exchanger Orientation

Either vertical or a horizontal installation possible.

4.2.4 Hub

Ball Bearing with Shaft

The hub consists of an aluminium pipe including internal ball bearing. The diameter is 40mm.

4.2.5 Application Limits

Pressure Drop Limits

Minimum recommended pressure drop is 50 Pa (0.2" WC) Maximum allowed pressure drop is 300 Pa (1.2" WC)



NOTE! Lower pressure drops than the minimum stated will result in unreliable heat transfer, while higher pressure drops than the maximum specified can result in mechanical failure.



NOTE! The maximum allowed pressure drop must not be exceeded under any conditions since this can lead to mechanical failure.

Differential Pressure Limits

No upper limit is set since sealing and thereby leakage in the model EN is the responsibility of the customer.



NOTE! The highest pressure should be on the supply side to guarantee a clean and fresh air inside the building; otherwise exhaust air can leak into the supply air.

Temperature Limits

Approved temperature range is -40 to +65°C for model EN.

4.3 Model O

Model O is an unsegmented wheel only.

4.3.1 Dimensions

- Wheel diameter: 500-2575mm. Available in increments of 1mm.
- Wheel depth: 200mm.
- Shaft length: 220mm with a diameter of 20mm.

4.3.2 Matrix Material & Well Heights

Aluminum/Epoxy	Hybrid with Silica gel*	Silica gel*	Hybrid with molecular sieve	Molecular Sieve
1.4 mm (0.055")	1.4 mm (0.055")	-	1.4 mm (0.055")	-
1.6 mm (0.063")	1.6 mm (0.063")	1.6 mm (0.063")	1.6 mm (0.063")	1.6 mm (0.063")
1.8 mm (0.071")	1.8 mm (0.071")	1.8 mm (0.071")	1.8 mm (0.071")	1.8 mm (0.071")
2 mm (0.079")	2 mm (0.079")	2 mm (0.079")	2 mm (0.079")	2 mm (0.079")
2.2 mm (0.087")	2.2 mm (0.087")	2.2 mm (0.087")	2.2 mm (0.087")	2.2 mm (0.087")
2.5 mm (0.098")	2.5 mm (0.098")	2.5 mm (0.098")	2.5 mm (0.098")	2.5 mm (0.098")

*Only available from Heatex China.

4.3.3 Exchanger Orientation

Vertical and horizontal installation possible. Wheels for horizontal installation have additional spokes and angular contact bearings.

4.3.4 Hub

Ball Bearing with Shaft

The hub consists of an aluminum pipe and an internal deep groove standard ball bearing. For wheel diameters up to 1100mm, the hub diameter is 90mm. Above 1100mm, the hub diameter is 180mm. The expected bearing lifetime at normal usage exceeds ten years.

In a scenario with the most challenging conditions (a 2575 mm (101.38") wheel at maximum pressure drop), the estimated lifetime of the bearings is above 55,000 hours (> 6 years). The construction with internal bearings (well protected against dirt) is chosen for its long lifetime and will keep maintenance needs low. Bearings can be replaced if necessary.

Ball Bearings with shaft, corrosion resistant.

Corrosion resistant shafts and bearings in stainless steel.

Spokes configuration

To secure the strength of the wheels, spokes are glued and welded to the wheel. Number of spokes vary depending on the size of the wheel.

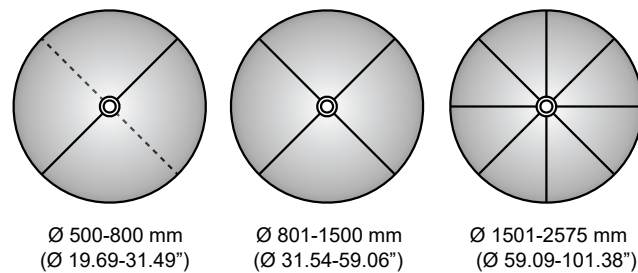

Image 12. Spokes on horizontal installed wheels.

The matrix of horizontal wheels is glued for extra strength and spokes are added as shown below.

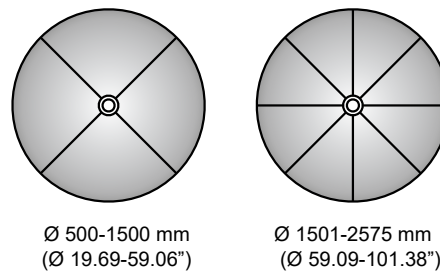

Image 13. Spokes on horizontal installed wheels.

4.3.5 Application Limits

Pressure Drop Limits

- Minimum recommended pressure drop is 50 Pa (0.2" WC).
- Maximum allowed pressure drop is 300 Pa (1.2" WC) if wheel diameter is below or equal to 1600 mm (62.99").
- Maximum allowed pressure drop is 250 Pa (1" WC) if wheel diameter is larger than 1600 mm (62.99").
- The recommended pressure drop under normal conditions is between 100-200 Pa (0.4-0.8" WC)



NOTE! Lower pressure drops than the minimum stated will result in unreliable heat transfer, while higher pressure drops than the maximum specified can result in mechanical failure.



NOTE! The maximum allowed pressure drop must not be exceeded under any conditions since this can lead to mechanical failure.

Differential Pressure Limits

No upper limit is set since sealing and thereby leakage for Model O must be taken into consideration by the AHU manufacturer.



NOTE! The highest pressure should be on the supply side to guarantee a clean and fresh air inside the building; otherwise exhaust air can leak into the supply air.

Temperature Limits

Approved temperature range is -40 to +65°C for model O.

4.4 Model ER

Model ER is a segmented wheel.

4.4.1 Dimensions

- Wheel diameter is available in the range of 1600-3800 mm. Available in increments of 1 mm.
- Wheel depth is 200 mm.
- Shaft length and diameter depends on wheel diameter:
 - Wheel diameter 1600-2800: Shaft length 405 mm, diameter 40 mm
 - Wheel diameter 2801-3800: Shaft length 405 mm, diameter 50 mm

4.4.2 Matrix Material & Well Heights

Aluminum/Epoxy	Hybrid with Silica gel*	Silica gel*	Hybrid with molecular sieve	Molecular Sieve
1.4 mm (0.055")	1.4 mm (0.055")	-	1.4 mm (0.055")	-
1.6 mm (0.063")	1.6 mm (0.063")	1.6 mm (0.063")	1.6 mm (0.063")	1.6 mm (0.063")
1.8 mm (0.071")	1.8 mm (0.071")	1.8 mm (0.071")	1.8 mm (0.071")	1.8 mm (0.071")
2 mm (0.079")	2 mm (0.079")	2 mm (0.079")	2 mm (0.079")	2 mm (0.079")
2.2 mm (0.087")	2.2 mm (0.087")	2.2 mm (0.087")	2.2 mm (0.087")	2.2 mm (0.087")
2.5 mm (0.098")	2.5 mm (0.098")	2.5 mm (0.098")	2.5 mm (0.098")	2.5 mm (0.098")

4.4.3 Exchanger Orientation

Vertical installation only.

4.4.4 Hub

The diameter of the hub is 286mm.

Bearings with shaft

Internal angular contact bearings are used for replacement wheel model ER. The bearings are press-fitted into the wheel, and a shaft is delivered along with the wheel, which will be fixed into the casing. These bearings are lubricated with a special grease, making them service-free.

Bearings without shaft

Internal angular contact bearings are used for replacement wheel model ER. The bearings are press-fitted into the wheel. These bearings are lubricated with a special grease, making them service-free. Delivered without shaft.

Fixed shaft without bearing

The shaft is press-fitted to the hub. The idea is to use an external bearing in the rotor casing or other construction supplied by the customer.

Bearings with shaft, corrosion resistant

If this option is chosen, a shaft made of stainless steel and corrosion-resistant bearings are used. These bearings are service-free.

4.4.5 Wheel Design

The segmented wheels are manufactured as a whole wheel, where each matrix layer is glued. The finished wheel is then divided into segments for easy delivery and installation. Spokes are mounted into the hub, holding each segment into place, and an external sweep is attached to the wheel's perimeter to keep it all in place. Both the spokes and sweeps are made of galvanized steel. The matrix is glued to the spokes in each segment

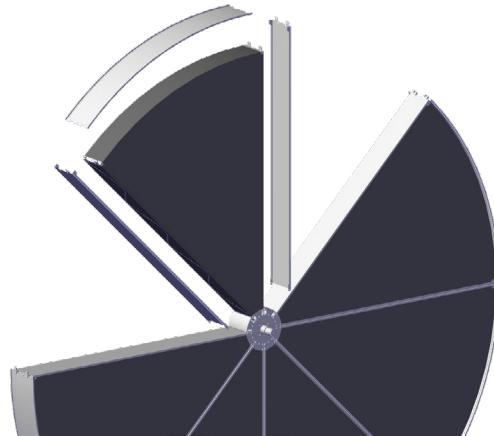

Image 14. Model ER spokes and segments

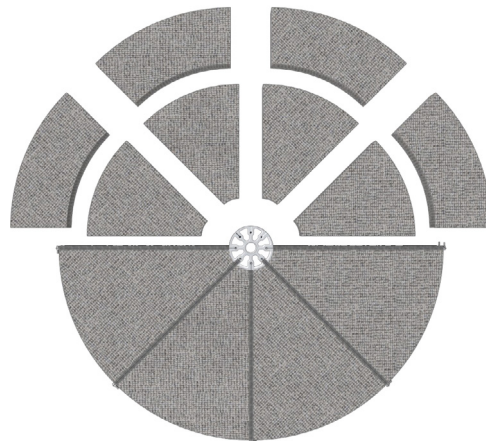

Image 15. Model ER division

Each wheel is divided into segments depending in the wheel diameter:

- For \varnothing 1600 - 2000 mm (62.99-78.74") 4 segments
- For \varnothing 2001 - 3800 mm (78.78-149.61") 8 segments

For easier handling each segment is further divided into either two or three pieces.

4.4.6 Delivery Options

Model ER (wheel only) can be delivered in three ways.

- Two Halves (A)
Meaning the wheel comes assembled as two halves. Mount them together.
- Segments (B)
Meaning two wheel halves come further disassembled into segments. Build the wheel segment by segment. Depending on size, it has four or eight segments. You may complete the assembly manually, depending on the weight of each segment.
- Split segments (C) - On request only!
Meaning the wheel comes disassembled (as in option B), but the segments need to be split into pieces and glued to the spokes. Assemble the complete wheel by joining the spokes to the hub, placing the segment pieces between the spokes (including applying glue), and fastening the sweeps. You may complete the assembly manually, depending on the weight of each segment piece.

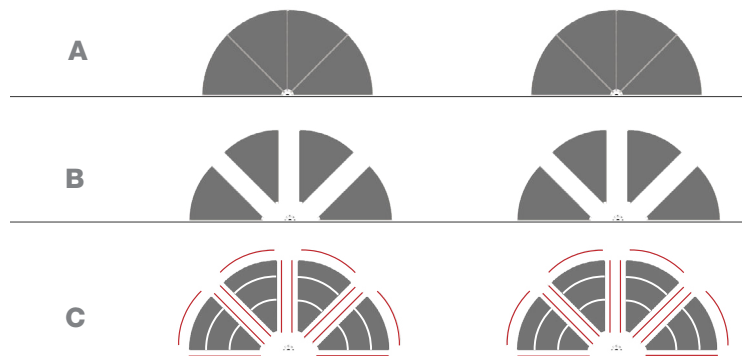

Image 16. Model ER delivery options

4.4.7 Application Limits

Pressure Drop Limits

- Minimum recommended pressure drop is 50 Pa (0.2" WC)
- Maximum allowed pressure drop is 250 Pa (1" WC), independent of wheel diameter.
- The recommended pressure drop under normal conditions is between 100-200 Pa (0.4-0.8" WC)



NOTE! Lower pressure drops than the minimum stated will result in unreliable heat transfer, while higher pressure drops than the maximum specified can result in mechanical failure.



NOTE! The maximum allowed pressure drop must not be exceeded under any conditions since this can lead to mechanical failure.

Differential Pressure Limits

Limit is depending on the sealing system and the acceptable leakage level



NOTE! The highest pressure should be on the supply side to guarantee a clean and fresh air inside the building; otherwise exhaust air can leak into the supply air.

Temperature limit

The approved temperature range is -40 to +65°C for model ER.

5. MODEL E & MODEL ES (WHEELS WITH CASING)

Note that Model E is Model O with casing and Model ES is model ER with casing.

5.1 Model E Description

	E	A	0700x0700	-	0650	V	-	020	-	2	B	D	OO	-	8	A	R	0	-	A
Pos.	1	2	3		4	5		6		7	8	9	10		11	12	13	14		15

Pos.		Configuration
1	Heat exchanger model	E = Unsegmented wheel and casing
2	Matrix material	A = Aluminum E = Epoxy K = Hybrid (with silica gel) L = Hybrid (with molecular sieve) D = Silica gel M = Molecular sieve
3	Casing dimensions	Width x height in mm
4	Rotor diameter	in mm
5	Exchanger orientation	H = Horizontal V = Vertical
6	Well height	in mm
7	Hub	2 = Ball bearing with shaft 7 = Ball bearing with shaft, corrosion resistant
8	Casing type	B = Covered casing D = Standard casing E = Covered casing with sidewise airflow G = Standard casing with sidewise airflow
9	Purge sector	0 = No purge sector A = Front side on the right resp. front side upwards B = Front side on the left resp. front side downwards C = Back side on the right resp. back side upwards D = Back side on the left resp. back side downwards X = Delivered separately
10	Casing options	OO = Standard product DB = Corrosion protected framework RA = Inspection hatches RB = Condensate tray motor side RC = Condensate tray non-motor side RD = Cable glands CI = According to special drawing/instruction Note! Combinations of options are described in a separate document.
11	Drive equipment	0 = No drive 1 = Constant drive 1 Phase, 230 V, Mate-n-lok 6 = Constant drive 3 Phases, 380 V 7 = Constant drive 3 Phases, 230 V 8 = IBC Varimax step drive 9 = Constant drive 3 Phases, 400 V, Mate-n-lok A = OJ DHRX + MRHX step drive with Modbus B = IBC Varimax NG step drive with Modbus C = IBC Varimax Mate-n-lok

11*	Drive equipment	0 = No drive E = Constant drive 115 V / 1 Ph / 60 Hz F = Constant drive 208 V / 3 Ph / 60 Hz H = Constant drive 460 V / 3 Ph / 60 Hz I = Constant drive 575 V / 3 Ph / 60 Hz
12	Motor position	0 = No motor A = Floor, left side B = Floor, right side E = Floor, left side. Control unit not attached to casing. F = Floor, right side. Control unit not attached to casing.
13	Drive belt	0 = No drive P = Power belt
14	Rotation Detector	0 = No detector I = With detector
15	Seal	A = Brush seal B = Special brush seal
16	Region	NA = North American product (AHRI certified) Empty = Eurovent certified

* With some exceptions, see Figure 15 for all combinations.

* Motor options for the North American market.

5.1.1 AHU Design Requirements

The air handling unit or installation area where the heat exchanger is installed must meet the following requirements.

- The system designer needs to ensure that the heat exchanger can be removed for inspection, maintenance, service, cleaning, and disinfection.
- If condensate is present, the air handling unit and duct system designer must design and install a condensation tray according to the norm VDI 6022.

Casing Support at Vertical Installation

- The surrounding air handling unit (AHU) structure must absorb the high forces acting on the casing generated by the airflows.
- The surrounding AHU should not be able to flex more than ± 1 mm in any position specified in the figure below while subjecting to the forces shown in Figure 22.
- Extra attention should be given to position four as the position is exposed to high forces. Ensure the rotor is installed on a horizontal level surface to prevent warping.
- Due to the orientation of the casing, the positions of the forces also need to be rotated according to Figure 23 side-by-side installation.

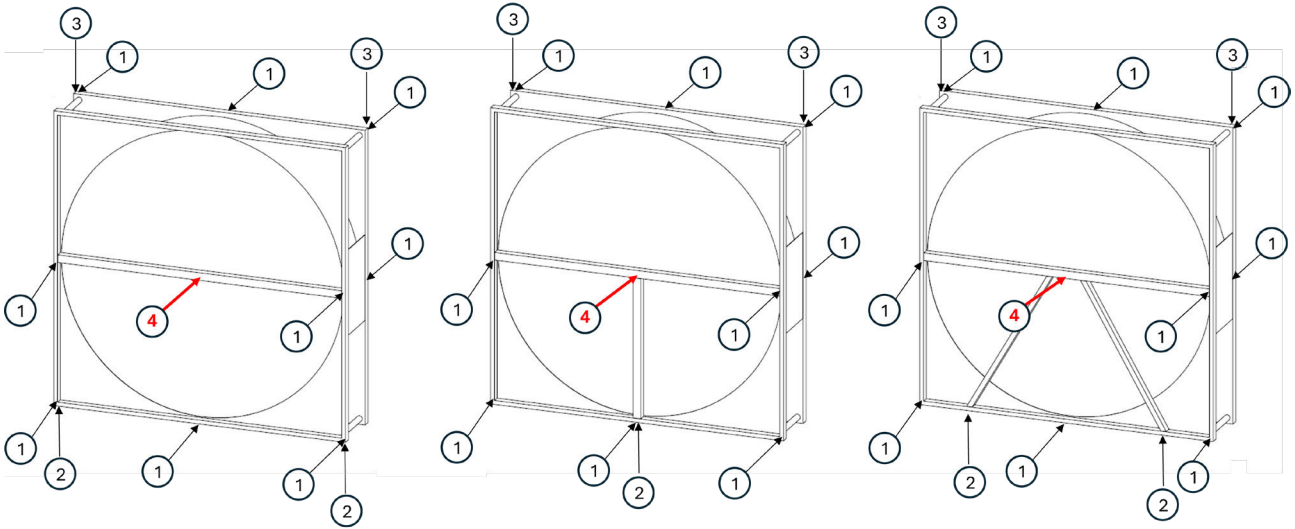

Image 17. Vertical top/ bottom airflow.

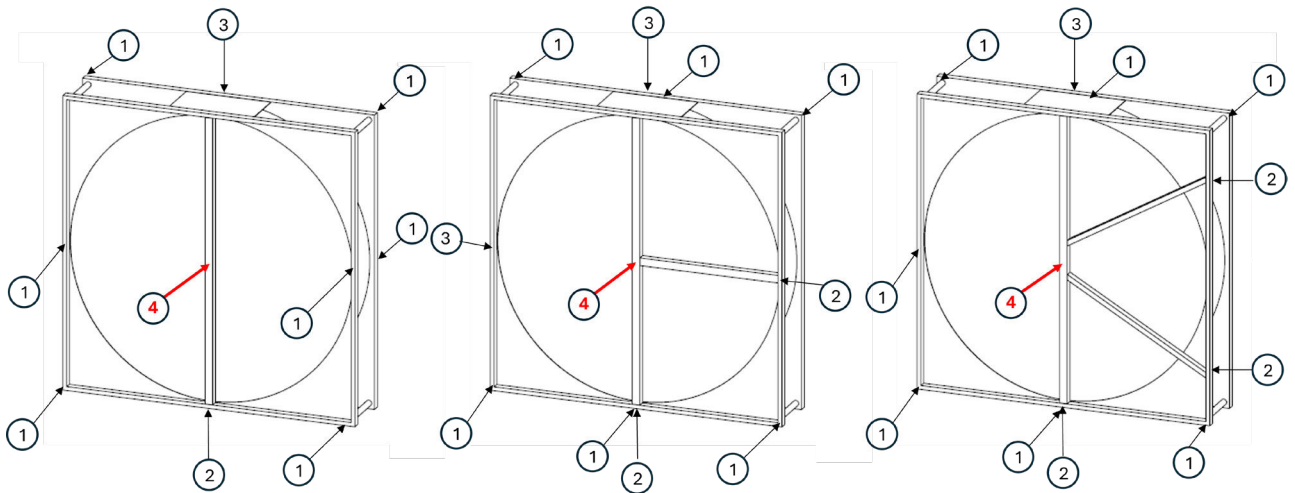

Image 18. Vertical side by side airflow.

Force	Direction of force	Small	Medium	Large
1	Against airflow	0.4 kN	0.5 kN	0.7 kN
2	Vertically up	2 kN	5 kN	5 kN
3	Vertically down	0.5 kN	0.6 kN	0.8 kN
4	Against airflow	0.5 kN	1 kN	2 kN

Casing Support at Horizontal Installation

- The casing should be supported along the entire frame. See the figure below.
- Extra attention should be given to the cross beam underneath at position 4. The maximum allowed deformation in this position is ± 1 mm.
- Ensure the rotor is installed on a horizontal level surface to prevent warping.

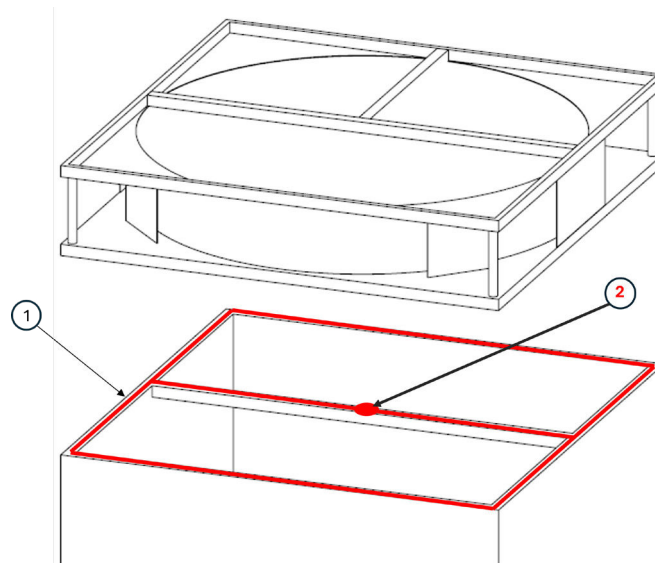

Image 19. Model E support areas required for horizontal installation.

5.1.2 Dimensions

The model E casing is manufactured in three different versions, depending on the diameter of the rotor: small, medium, or large.



Image 20. Model E casing types small, medium and large.

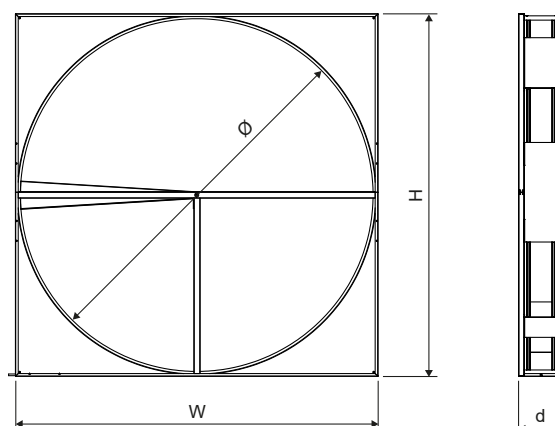

Image 21. Model E casing dimensions

The below figures describes the relation between wheel diameter and casing size. The minimum casing size is determined by the selected drive and the rotor diameter (\emptyset).

Casing type	Wheel diameter \emptyset (mm) ¹	H x W ² Variable drive (mm)	H x W ² Constant drive (mm)	Casing depth d (mm)
Small	500-1100	min \emptyset +50	min \emptyset +100	276 or 290
Medium	1101-1500	min \emptyset +50	min \emptyset +50	316 or 290
Large	1501-2575	min \emptyset +50	min \emptyset +50	316 or 290

Image 22. Model E casing division, metric units.

Casing type	Wheel diameter \emptyset (in)	H x W ¹ Variable drive (in)	H x W ² Constant drive (in)	Casing depth d (in)
Small	19.61-43.31	min \emptyset +1.97	min \emptyset +3.94	10.87 or 11.42
Medium	43.31-59.06	min \emptyset +1.97	min \emptyset +1.97	12.44 or 11.42
Large	59.09-101.4	min \emptyset +1.97	min \emptyset +1.97	12.44 or 11.42

Image 23. Model E casing division, imperial units.

¹ Wheel diameter can be selected in steps of 1 mm.

² Height (H) and Width (W) can be adapted according to customers' requirements in steps of 1 mm.

5.1.3 Matrix Material & Well Heights

See Model O "Matrix Material and Well Heights".

5.1.4 Seal

There are two options of seals for Model E.

Brush Seal

The brush seal consists of two layers of yarn with a plastic foil in between.



Special Brush Seal

The special brush seal consists of one layer of rigid yarn with a supporting rubber lip.



5.1.5 Exchanger Orientation

The rotor may be installed either vertically or horizontally. If a horizontal installation is required, make sure to select this option, as the vertical unit cannot be installed horizontally due to differences in the wheel's construction.

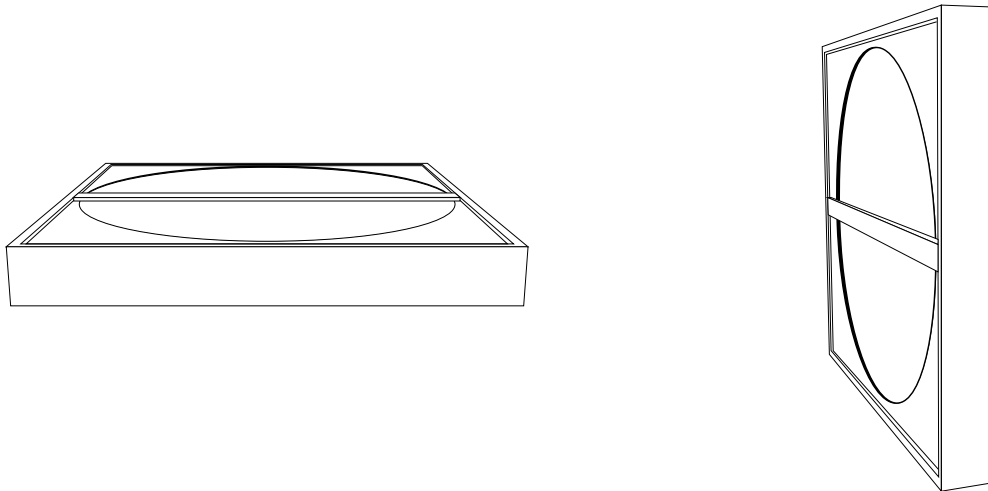

Image 24. Vertical rotor position (left) and horizontal rotor position (right).

5.1.6 Hub

Ball Bearings with Shaft

Normal usage exceeds ten years. In a scenario with the most challenging conditions (a 2575 mm (101.38”) wheel at maximum pressure drop), the estimated lifetime of the bearings is above 55,000 hours (>6 years). The construction with internal bearings (well protected against dirt) is chosen for its long lifetime and will keep maintenance needs low. Bearings can be replaced if necessary.

Corrosion Resistant Shaft and Bearings

For highly exposed rotors Heatex offers corrosion resistant shafts and bearings in stainless steel.

5.1.7 Purge Sector

Refer to section "Purge Sector" in the chapter "Rotary Heat Exchanger Design".

5.1.8 Drive Equipment

There are two types of drive equipment;

- Variable speed with controller. The option is suitable when capacity control and better monitoring of the wheel and motor is required. The solution is available with both 0-10V and Modbus control.
- Constant motor without controller. This is a less complex solution, it is an on/off solution controlled by power input

Variable Step Drive with Controller

The variable speed drive is a stepping motor with an input signal of 0-10 volts. There is also an optional variable speed drive with a controller that includes Modbus functionality.

The below figure compares the input power of a constant (AC) motor with a gear and a stepping motor (both with a controller) depending on the rotary speed. The behavior of the stepping motor allows the customer to regulate the rotor speed without higher power consumption.

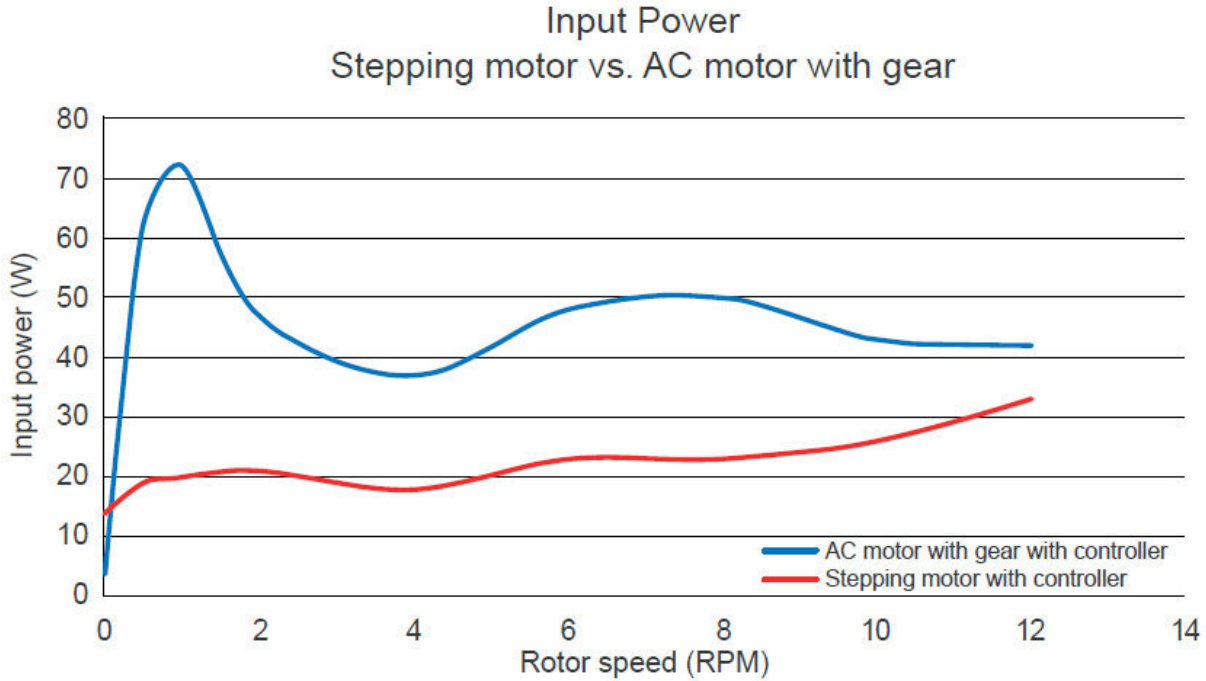

Image 25. Input power vs rotor speed for a gearbox motor and a step motor.

At standard conditions (12 rpm), the step motor consumes around 20% less power. The motor size depends on the wheel diameter. Figure 33 presents the different motor options in combination with matrix material and diameter. Critical parameters for control and motor are shown in Figure 34.

Drive	Condensation & enthalpy wheels (Ø)	Condensation & enthalpy wheels + special brush seal	Adsorption wheels molecular sieve (Ø)	Adsorption wheels molecular sieve (Ø) + special brush seal
IBC Varimax 25 NG	500-1500 mm (19.69-59.06")	500-1500 mm (19.69-41.34")	500-900 mm (19.69-35.43")	500-900 mm (19.69-35.43")
IBC Varimax 50 NG	1501-2575 mm (59.09-101.38")	1501-2300 mm (41.38-90.55")	901-1200 mm (35.47-47.24")	901-1200 mm (35.47-47.24")
IBC Varimax 100 NG	-	2301-2575 mm (90.59-101.38")	1201-2575 mm (47.28-101.38")	1201-2575 mm (47.28-101.38")
OJ MRHX 2Nm	500 - 1300 mm (19.69 - 51.18")	500 - 1300 mm (19.69 - 51.18")	500 - 1000 mm (19.69 - 39.37")	-
OJ MRHX 4Nm	1301 - 2575 mm (51.22 - 101.38")	1301 - 2300 mm (51.22 - 90.55")	1001 - 1700 mm (39.41 - 66.93")	500 - 1100 mm (19.69 - 43.311")
OJ MRHX 8Nm	-	2301 - 2575 mm (90.59 - 101.38")	1701 - 2575 mm (66.97 - 101.38")	1101 - 2575 mm (43.35 - 101.38")

Drive	Max torque (Nm)	Supply power (V-Hz)	Input current max (A)	Protection form, control/ motor
IBC Varimax 25 NG	2	1x230 - 50/60	0.8	IP44/IP54
IBC Varimax 50 NG	4	1x230 - 50/60	1.65	IP44/IP54
IBC Varimax 100 NG	10	1x230 - 50/60	2.2	Type 1/IP54
OJ MRHX 2Nm	2	1x230 - 50/60	0.6	IP54
OJ MRHX 4Nm	4	1x230 - 50/60	1.2	IP54
OJ MRHX 8Nm	8	1x230 - 50/60	2.4	IP54



NOTE! The small casing sizes (Ø 500-900 mm (19.69-35.43")) the controller for the variable speed motor will be delivered separately.

Constant Drive

The constant drive operates with a constant rotor speed. The speed depends on the matrix material. All motors are induction motors, supplied with AC power, and are equipped with a thermal contact.

Condensation & Enthalpy Wheels (Ø)	Adsorption Wheels (Ø)	Nominal power	Supply (V/ Hz)	Nominal speed (RPM)	Current ¹ (A)	Pole number	IP class	Mass with gear
500-800 mm (19.69-31.5")	500-600 mm (19.69-23.62")	25 W	3x220-240/50	1250	0.18-0.28	4	IP54	2.1 kg (4.63 lb)
			3x380-420/50	1250	0.11-0.14	4	IP54	2.1 kg (4.63 lb)
801-1300 mm (31.54-51.18")	601-1300 mm (23.66-51.18")	40 W	3x220-240/50	1250	0.3-0.39	4	IP54	4.1 kg (9.04 lb)
			3x380-420/50	1300	0.17-0.22	4	IP54	4.1 kg (9.04 lb)
1301-1500 mm (51.22-59.06")	-	90 W	3x220-240/502	1400	0.66-0.7	4	IP55	3.9 kg (8.60 lb)
			3x380-420/50	1350	0.35-0.45	4	IP55	3.9 kg (8.60 lb)
1501-2200 mm (59.09-86.61")	-	180 W	3x220-240/502	1350	0.96-1.3	4	IP55	5.1 kg (11.24 lb)
			3x380-420/50	1350	0.6-0.7	4	IP55	5.1 kg (11.24 lb)
-	1301-1700 mm (51.22-59.06")	180 W	3x220-240/502	2840	0.8-0.95	2	IP55	4.1 kg (9.04 lb)
			3x380-420/50	2840	0.5-0.6	2	IP55	4.1 kg (9.04 lb)
2201-2575 mm (86.65-101.38")	1701-2575 mm (66.97-101.38")	370 W	3x220-240/502	2830	1.63-1.7	2	IP55	7.6 kg (16.76 lb)
			3x380-420/50	2830	0.9-1.0	2	IP55	7.6 kg (16.76 lb)

¹ Current depends on motor brand.

² Delivered in 3x400V mode (Y-connection), customer arrange switching to 3x230V (Delta-connection).



NOTE! Due to the compactness of the model E casing and the size of the constant motors, the model E outer dimensions need to be modified if a constant motor is chosen from size 500 mm (19.69") to 1100 mm (43.31").



NOTE! The constant motor should be protected against over current by a separate and appropriate motor protection switch.

5.1.9 Drive Location

Drive units are located on the casing floor, either on the left (A) or right (B). When a control unit is included, it is installed on the same side above the motor. Due to the lack of space, the control unit is delivered loose for rotors sized Ø900 and smaller.

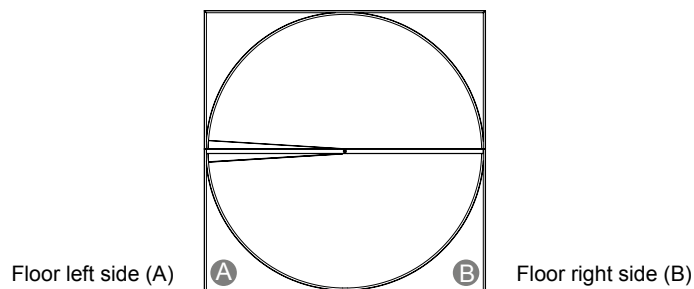

Image 26. Drive location



NOTE! Make sure that there is a 30s acceleration time while starting or stopping the rotation.

5.1.10 Drive Belt

Power Belt

The power belt is a robust solution that can be joined without tools; it does not require a tension device.



Image 27. Power belt.

5.1.11 Application Limits

Pressure Drop Limits

- Minimum allowed pressure drop is 50 Pa (0.2" WC).
- Maximum allowed pressure drop for rotors equal to or smaller than Ø1600 mm (62.99") is 300 Pa (1.2" WC).
- Maximum allowed pressure drop for rotors larger than Ø 1600 mm (62.99") is 250 Pa (1" WC).

The recommended pressure drop under normal conditions is between 100-200 Pa (0.4-0.8" WC).

Differential Pressure Limits

- Maximum differential pressure allowed is 500 Pa (2.01" WC) between the supply air inlet and exhaust air outlet.



NOTE! Lower pressure drops than the minimum stated will result in unreliable heat transfer, while higher pressure drops than the maximum specified can result in mechanical failure.



NOTE! The maximum allowed pressure drop must not be exceeded under any conditions since this can lead to mechanical failure.



NOTE! The highest pressure should be on the supply side to guarantee a clean and fresh air inside the building; otherwise exhaust air can leak into the supply air.

Maximum recommended differential pressure is 500 Pa (2 "WC). This is to reduce the wear on the bearings and sealings. Note that a higher differential pressure will result in increased leakage rates and may cause the casing to deflect. For optimal performance of the purge sector, the pressure difference should be between 200 Pa (0.8" WC) and 1500 Pa (2" WC).

Temperature Limits

The overall air temperature limits for the whole unit are -40 °C (-40 °F) to +65 °C (149 °F). Each component has different temperature limits; see Figure 37 below for details. The temperature inside the casing is estimated to be the average temperature between the supply and the exhaust inlet temperatures.

Component	Min Temp.	Max Temp.
Bearings	-40 °C (-40 °F)	110 °C (230 °F)
Power belt	-40 °C (-40 °F)	110 °C (230 °F)
Constant motor	-20 °C (-4 °F)	40 °C (104 °F)
Step drive (Varimax and control)	-30 °C (-22 °F)	45 °C (113 °F)
Step drive (OJ and control with modbus)	-40 °C (-40 °F)	40 °C (104 °F)
Brush seals	-25 °C (-13 °F)	70 °C (158 °F)
Special brush seals	-25 °C (-13 °F)	90 °C (190 °F)



NOTE! The AHU manufacturer should take into consideration the positioning of the motor so that the temperature limits are kept.

5.2 Model ES Description

	ES	A	2950x2950	-	2700	V	-	020	-	6	D	C	OO	-	4	A	P	0	-	0
Pos.	1	2	3		4	5		6		7	8	9	10		11	12	13	14		15

Pos.		Configuration
1	Heat exchanger model	ES = Segmented wheel and casing
2	Matrix material	A = Aluminum E = Epoxy K = Hybrid (with silica gel) L = Hybrid (with molecular sieve) D = Silica gel M = Molecular Sieve
3	Casing dimensions	Width x height in mm
4	Rotor diameter	in mm
5	Exchanger orientation	V = Vertical
6	Well height	in mm
7	Hub	6 = External ball bearings 7 = External ball bearings, corrosion resistant
8	Casing type	B = Covered casing D = Standard casing E = Covered casing with airflow sidewise G = Standard casing with airflow sidewise I = Insulated casing K = Insulated casing with airflow sidewise
9	Purge sector	0 = No purge sector A = Front side on the right resp. front side upwards B = Front side on the left resp. front side downwards C = Back side on the right resp. back side upwards D = Back side on the left resp. back side downwards X = Delivered separately E = Clean blade down/ right, regulator to the right F = Clean blade down/right, regulator to the left G = Clean blade up/ left regulator to the right H = Clean blade up/ left regulator to the left M = A+E N = B+G P = C+E R = D+G S = A+F T = B+H U = C+F V = D+H
10	Casing options	OO = Standard product DB = Corrosion protected framework CI = According to drawing
11	Drive equipment	0 = No drive 4 = IBC Micromax drive & control 6 = Constant drive 3 Phase, 380V

12	Motor position	0 = No motor A = Floor, left side B = Floor, right side
13	Drive belt	0 = No drive P = Power belt
14	Rotation Detector	0 = No detector I = With detector
15	Delivery Options	A = Two halves B = Segments C = Split segments

5.2.1 AHU Design Requirements

The air handling unit or installation area where the heat exchanger is installed must meet the following requirements.

- The system designer needs to ensure that the heat exchanger is accessible for inspection, maintenance, service, cleaning, and disinfection.
- If condensate is present, the air handling unit and duct system designer must design and install a condensation tray according to the norm VDI 6022.
- A 200 mm clearance above and below the bearings on both sides is recommended for easy adjustments of the rotor position.
- The casing is design to be installed in an AHU or similar casing, shielding the heat exchanger from external environment.
- The frame is constructed of welded aluminium profiles, and the sheet metal material of the casing is galvanized steel.
- Casing is delivered in two halves and can be assembled either before or after it is positioned.
- Recommended design easy access to the motor location for inspection and maintenance.

Casing Support

- The Model ES casing is designed as a slide-in solution to be supported by the AHU structure which must absorb the high forces acting on the HEX generated by the airflows.
- The casing is not required to be fixed to the surrounding AHU.
- The surrounding AHU should not be able to flex more than ± 1 mm in the specified positions in figure XX whilst being subjected to the forces shown in figure XX.
- Ensure the rotor is installed on a horizontal level surface to prevent warping.
- Note the change in forces distribution at side-by-side installation.

Model ES Force Schedule

Table shows the accumulated total force in each direction, which is distributed along the positions mentioned in figures 38 and 39.

Force	Direction of force	D < Ø2000	Ø2001 < D < Ø2800	Ø2801 < D < Ø3800
1	Against airflow	0.8	1.2 kN	1.8 kN
2	Vertically up	6 kN	10 kN	18 kN
3	Vertically down	0.6 kN	0.8 kN	1.2 kN
4	Against airflow	1 kN	2 kN	3 kN

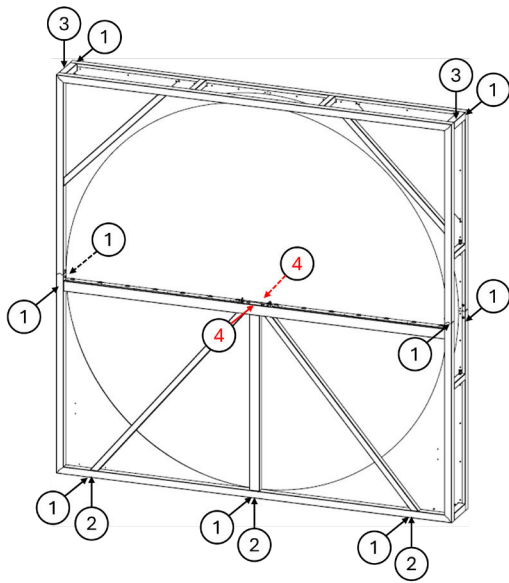

Image 28. Forces - Horizontal plane of intersection

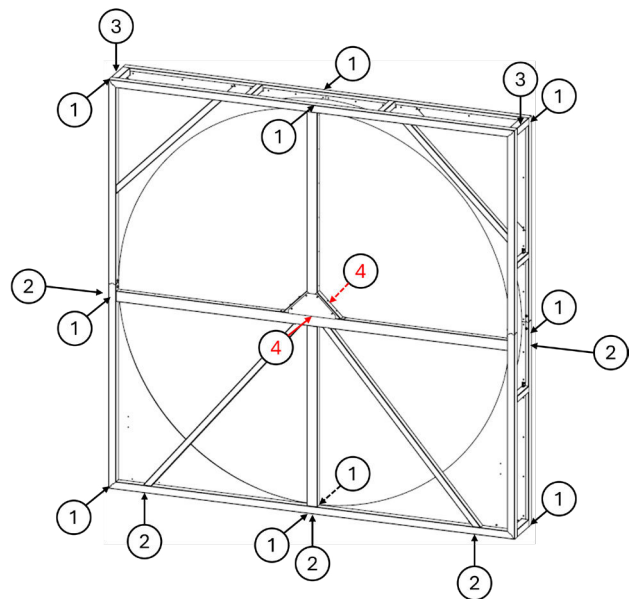

Image 29. Forces - Vertical plane of intersection

5.2.2 Dimensions

The model ES casing is manufactured in two different versions, depending on the diameter of the rotor: small and large.

The below figures describes the relation between wheel diameter and casing size. The minimum casing size is determined by the rotor diameter (Ø).

The casing is best suited for indoor applications and it can either be mounted with ducts or be directly mounted to the AHU.



Image 30. Model ES

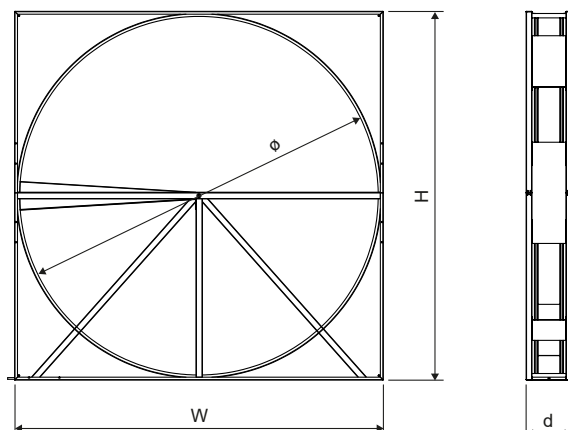

Image 31. Model ES casing dimensions

Casing type	Wheel diameter Ø (mm) ¹	Height x Width ² HxW (mm)	Casing depth d (mm)
Small	1600-1900	min Ø + 100	410
Large	2801-3800	min Ø + 100	430

Casing type	Wheel diameter Ø (in)	Heigh x Width ² HxW (mm)	Casing depth d (in)
Small	62.99 - 74.8"	min Ø +3.9"	16.14"
Large	110.25 - 149.61"	min Ø +3.9"	16.93"

¹ Wheel diameter can be selected in steps of 1 mm.

² Height (H) and Width (W) can be adapted according to customers' requirements in steps of 1 mm.

5.2.3 Matrix Material & Well Heights

See Model ER "Matrix Material & Well Heights".

5.2.4 Seal

Brush Seal

All casings are monted with an adjustable brush sealing. The brush seal consist of two layers of yarn with a plastic foil in between. Special brush seal is not available for Model ES.



Image 32. Brush seal

5.2.5 Exchanger Orientation

Model ES is only available for vertical installations.

5.2.6 Hub

External Bearing

Self-aligning externally mounted pillow block bearings are used for Model ES. The bearings are mounted external for easy access. Specially adapted grease is used for lubrication which makes them service-free.

External Bearings, Corrosion Resistant

For highly exposed rotors Heatex offers corrosion resistant shafts and bearings in stainless steel. These bearings are service-free.

5.2.7 Purge Sector

Refer to section "Purge Sector" in the chapter "Rotary Heat Exchanger Design".

5.2.8 Drive Equipment

There are two types of drive equipment;

- Constant motor without controller. This is a less complex solution, it is an on/off solution controlled by power input.
- IBC Micromax variable drive

Independent of drive unit type the rotor performance is based on standard rotation speeds, see table below.

Matrix material	Standard rotational speed (rpm)
Condensation & Enthalpy	12
Adsorption (Silica gel)	17
Adsorption (Molecular sieve)	20



NOTE! Heatex strongly recommends that the motor and controls are placed easily accessible.

Constant Drive

The constant drive operates with a constant rotor speed. The speed depends on the matrix material. All motors are induction motors, supplied with AC power, and are equipped with a thermal contact.

Condensation and hybrid rotor	Adsorption rotor	Nominal Power	Supply (V/Hz)	Nominal speed (RPM)	Nominal current ¹ (A)	Pole number	Iso class	IP class	Mass with gear
1600-2100 mm (59.09-82.68")	-	180 W	3x400/50	1350	0.6-0.7	4	63	IP55	5.1 kg (11.24 lb)
-	1600-1700 mm (66.92-66.93")	180 W	3x400/50	2840	0.5-0.6	2	63	IP55	4.5 kg (9.92 lb)
2101-3100 mm (82.72-122.05")	1701-2500 mm (66.97-98.43")	370 W	3x400/50	2840	0.9-1.0	2	71	IP55	7.6 kg (16.76 lb)
3101-3800 mm (122.09-149.61")	2501-3800 mm (98.46-149.61")	750 W	3x400/50	2890	1.6-2.0	2	80	IP55	13.6 kg (29.98 lb)

¹ Current depends on motor brand.



NOTE! The constant motor should be protected against over current by a separate and appropriate motor protection switch.

Variable Drives

The unit includes drive, pulley, rotation detector and controller. The frequency controller allows use of standard 3-phase motors with associated gearing.

- Standard motors
- IP54
- Alarm indication
- Cleaning function
- Input signal 0-10 V

MicroMax series are available for all rotor sizes, the control unit designation denotes motor output. Standard rotor speed according to Table 53 is set to provide the best performance. Rotor speed can be lowered if needed. The effect of lowered rotor speed can be calculated in Heatex Select.

Drive set	Condensation & enthalpy wheels (Ø)	Adsorption wheels silica gel (Ø)	Adsorption wheels molecular sieve (Ø)
MicroMax180	1600-2100 mm (59.09-101.38")	1600-1700 mm (39.41"-70.87")	1600-1700 mm (35.47-47.24")
MicroMax370	2101-3100 mm	1701-2500 mm (70.91-101.38")	1701-2500 mm (47.28-101.38")
MicroMax750	3101-3800 mm (19.69 - 59.06")	2501 - 3800 mm (19.69 - 39.37")	2501 - 3800 mm (19.69 - 35.43")

Drive Set	Supply Voltage and frequency (V-Hz)	Input current max (A)	Protection form, controller and motor	Temp. min-max
MicroMax180	1x230 - 50/60	1.7	IP54	0-45 °C (32-113 °F)
MicroMax370	1x230 - 50/60	2.8	IP54	0-45 °C (32-113 °F)
MicroMax750	1x230 - 50/60	5	IP54	0-45 °C (32-113 °F)

5.2.9 Drive Location

Drive units are located on the casing floor, either on the left side (A) or on the right side (B). When a control unit is included, it is installed on the same side above the motor.

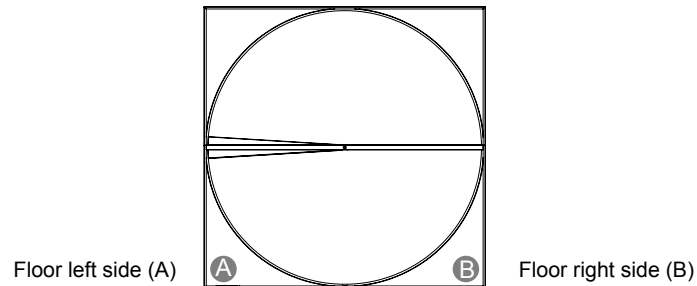

Image 33. Drive locations

5.2.10 Drive Belt

The power belt is a more robust solution that can be joined without tools; it does not require a tension device.

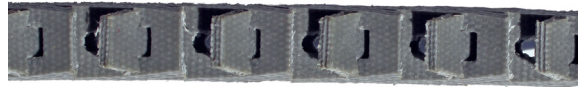

Image 34. Power belt.

5.2.11 Application Limits

Pressure Drop Limits

- Minimum allowed pressure drop is 50 Pa (0.2" WC)
- Maximum allowed pressure drop for rotors larger than Ø 1600 mm (62.99") is 250 Pa (1" WC).

The recommended pressure drop under normal conditions is between 100-200 Pa (0.4-0.8" WC).



NOTE! Lower pressure drops than the minimum stated will result in unreliable heat transfer, while higher pressure drops than the maximum specified can result in mechanical failure.



NOTE! The highest pressure should be on the supply side to guarantee a clean and fresh air inside the building; otherwise exhaust air can leak into the supply air.

Differential Pressure Limits

- Maximum differential pressure allowed is 500 Pa (2 "WC) between the supply air inlet and exhaust air outlet.

Maximum recommended differential pressure is 500 Pa (2 "WC). This is to reduce the wear on the bearings and sealings. Note that a higher differential pressure will result in increased leakage rates and may cause the casing to deflect. For optimal performance of the purge sector, the pressure difference should be between 200 Pa (0.8" WC) and 500 Pa (2" WC).

Temperature Limits

The overall air temperature limits for the whole unit are -40 °C (-40 °F) to +65 °C (149 °F). Each component has different temperature limits; see Figure 56 below for details. The temperature inside the casing is estimated to be the average temperature between the supply and the exhaust inlet temperatures.

Component	Min Temp.	Max Temp.
Bearings	-40 °C (-40 °F)	110 °C (230 °F)
Power belt	-40 °C (-40 °F)	110 °C (230 °F)
Constant motor ¹	-20 °C (-4 °F)	40 °C (104 °F)
Standard controller	0 °C (32 °F)	45 °C (113 °F)
Brush seals	-25 °C (-13 °F)	70 °C (158 °F)

¹ Thermal contacts release at 150 °C (302 °F) inner air temperatures.



NOTE! The AHU manufacturer should take into consideration the positioning of the motor so that the temperature limits are kept.

5.2.12 Delivery Options

Model ES (wheel with casing) can be delivered in three ways.

Two Halves (A)

Meaning the wheel comes assembled as two halves. The bottom part of the wheel is already mounted in the casing, and the top half is to be lifted upon it. Use a lifting device for this process.

Segments (B)

Meaning the bottom half of the wheel is already mounted in the casing, but the top half of the wheel comes disassembled into segments. Lift the top half of the casing onto the bottom half. Place the wheel segments (two or four segments) for the top half of the wheel onto the bottom half, one segment at a time. The assembly may be completed manually, depending on the weight of each segment piece.

Split segments (C) - On request only!

Meaning the bottom half of the wheel is already mounted in the casing. The top half wheel comes disassembled (as in option B), but the segment pieces need to be glued to the spokes. Lift the top half of the casing onto the bottom half. For the top half of the wheel, first disassemble the spokes and sweeps from the segments. Then assemble the complete wheel by joining the spokes to the hub, placing the segment pieces between the spokes (including applying glue), and fastening the sweeps. The assembly may be completed manually, depending on the weight of each segment piece.

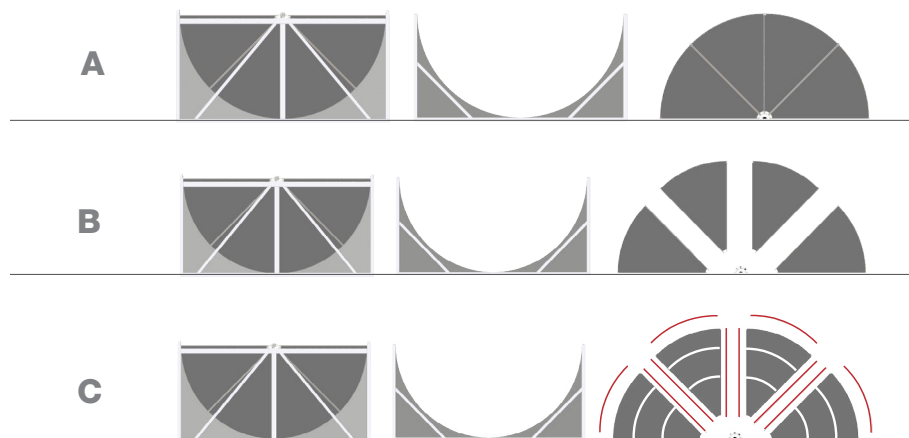

Image 35. Delivery options.

6. CASING OPTIONS

6.1 Corrosion Protected Framework

When corrosion protection is required, e.g., in wet and humid or industrial applications, choose a corrosion-protected casing. The protection consists of a grey polyester powder coating that is applied electrostatically and then melted in an oven/furnace. The thickness is 70 - 110 μm . For model ES the framework is then configured with Aluminium parts and Magnelis (ZM310) sheet metal parts.

6.2 Inspection Hatches

The rotor heat exchanger casing can be equipped with inspection hatches for inspection and service. For example, an inspection hatch facilitates access to the drive unit.

6.3 Cable Glands

Cable glands lead cables from one side of a metal sheet to the other without affecting the environment on either side since cable glands are usually airtight to a high level.

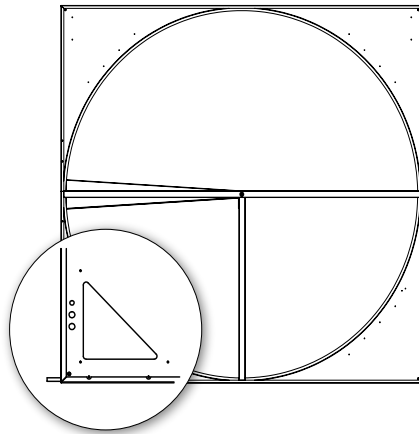

Image 36. Model E inspection hatch and cable glands

6.4 Covered Casing

This includes metal sheets closing the sides of the casing. The design and dimensions are the same as the standard model. On Model ES the lower side covers are attached with quick locks for easy access to the motor.

6.5 Condensation Tray

With rising humidity, the risk of condensation increases. The purpose of the stainless-steel condensation tray is to gather the condensed water and easily transfer it to the outside of the AHU. The condensation tray can be mounted with a drain either on the motor side or the non-motor side.

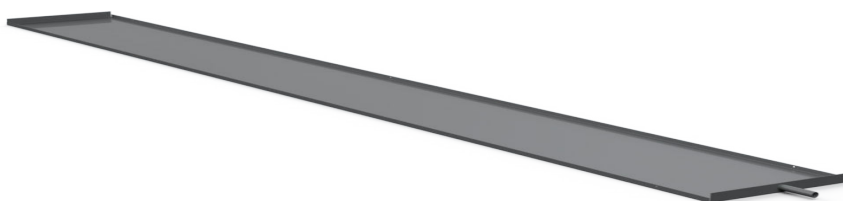

Image 37. Condensation tray

6.6 Casing Dimensions

6.6.1 Standard

- Casing dimensions for model E are by standard + 50 mm compared to the diameter of the rotor. For smaller diameters than 600 mm in combination with constant drive, the casing is + 100 mm.
- For model ES, the casing is + 100 mm by default compared to the diameter of the rotor.

6.6.2 Custom

For both models, the casing width and height can be modified, also non-symmetrically, up to the maximum allowed values. The depth of the casing (d) depends on the diameter of the rotor.

With rising humidity, the risk of condensation increases. The purpose of the stainless-steel condensation tray is to gather the condensed water and easily transfer it to the outside of the AHU. The condensation tray can be mounted with a drain either on the motor side or the non-motor side.

7. NOTES

7.1 ATEX

For applications with ATEX requirement a cross flow plate heat exchanger is the ideal choice. It is without rotating parts and the plate pack in aluminium can easily be grounded. However, some improvements can be done to a rotary heat exchanger, depending on the level of requirement, please contact Heatex.

8. DEFINITIONS AND FUNDAMENTALS

There are a few key terms and definitions that are good to know when diving into heat exchanger calculation and configuration.

8.1 Definition Description

Symbol	Formula	Term	Description
t		Temperature	It refers to the temperature of the airflows, presented as °C or °F.
x		Absolute humidity	It refers to the absolute humidity/moisture in the airflows, presented as humidity per weight dry air. Often as kg/kg, g/kg, lb/lb or gr/lb.
h		Total enthalpy	It refers to the total energy per kilogram stored in the airflows, presented as kJ/kg.
t_w		Wet bulb	Wet bulb temperature presented in °C or °F is a way to define the absolute humidity or moisture content in the air. At 100% relative humidity, the wet-bulb temperature is equal to the air temperature (dry-bulb temperature); at lower humidity the wet-bulb temperature is lower than dry-bulb temperature because of evaporative cooling.
t_d		Dry bulb	Dry bulb temperature presented in °C or °F is the temperature that thermometers read. It does not refer to the temperature with 0% relative humidity.
η_t	$\eta_t = \frac{t_{22} - t_{21}}{t_{11} - t_{21}}$	Temperature efficiency	Is defined as the temperature gain or lose divided by the maximum value of temperature difference, presented in %. In other words, the difference between the outlet and inlet temperature divided by the two inlet temperatures.
η_x	$\eta_x = \frac{x_{22} - x_{21}}{x_{11} - x_{21}}$	Humidity efficiency	Is defined as the moisture gain or lose divided by the maximum value of moisture difference, presented in %. In other words, the difference between the outlet and inlet moisture divided by the two absolute inlet moisture.
η_h	$\eta_h = \frac{h_{22} - h_{21}}{h_{11} - h_{21}}$	Total (enthalpy) efficiency	Is defined as the energy gain or lose divided by the maximum value of energy to transfer, presented in %. In other words, the difference between the outlet and inlet enthalpies divided by the inlet enthalpies.
ϵ_t	$\epsilon_t = \frac{\dot{m}}{\dot{m}_{min}} \cdot \frac{t_{22} - t_{21}}{t_{11} - t_{21}}$	Sensible effectiveness	Sensible effectiveness takes into account the difference in mass balance presented in %. It is calculated by multiplying the temperature efficiency times the specified mass airflow divided by the minimum airflow.
ϵ_x	$\epsilon_x = \frac{\dot{m}}{\dot{m}_{min}} \cdot \frac{x_{22} - x_{21}}{x_{11} - x_{21}}$	Latent effectiveness	Latent effectiveness takes into account the difference in mass balance, presented in %. It is calculated by multiplying the humidity efficiency times the specified mass airflow divided by the minimum airflow.
ϵ_h	$\epsilon_h = \frac{\dot{m}}{\dot{m}_{min}} \cdot \frac{h_{22} - h_{21}}{h_{11} - h_{21}}$	Total effectiveness	Total effectiveness takes into account the difference in mass balance, presented in %. It is calculated by multiplying the total efficiency times the specified mass airflow divided by the minimum airflow.