

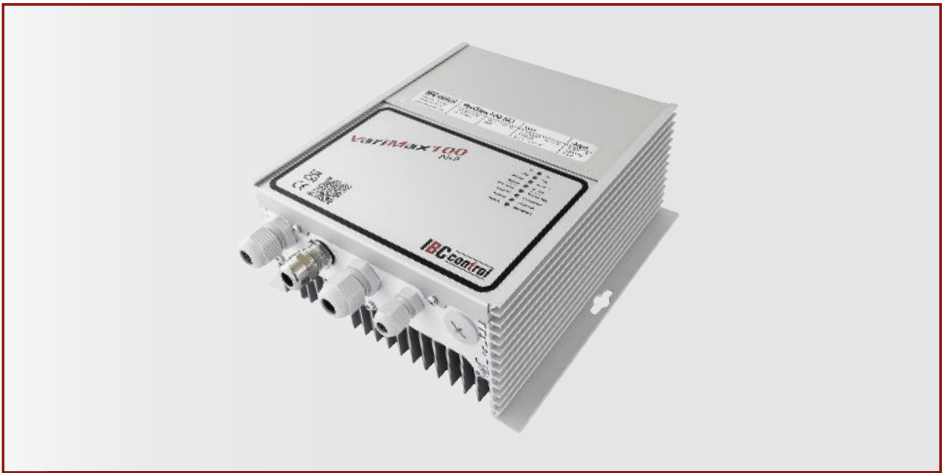

## MANUAL



CONTROL UNIT FOR ROTARY HEAT EXCHANGER

# VariMax 100 NG

Article no. F21100401

**IBC**control

## **EU DECLARATION**

This product has been designed and manufactured in accordance with applicable EU harmonisation legislation, including the EMC Directive 2014/30/EU and the Low Voltage Directive 2014/35/EU.

The EU Declaration of Conformity is held by the manufacturer and is available upon request or via our website at [www.ibccontrol.com](http://www.ibccontrol.com).

Environmental classification:  
Pollution Degree 2, Emission C1, Second Environment.

## TABLE OF CONTENTS



Installation Instructions	2
Safety instructions	2
Description of functions	3-4
Mounting	4
Technical data, control unit	5
Technical data, motor	5
Functions	6
- DIP switch	6
- Operational indications	7
- Alarms	7-9
- Settings via potentiometer	9
- Reset	9
EMC installation	10
EMC gland	10
Connection diagram	11
Connections	11-12
Input signal/Rotation speed	12
Checks before powering up the control unit	13
Putting the equipment into operation	13

## INSTALLATION INSTRUCTIONS

Warning indication 	The control unit must be in perfect technical condition before use. Damage that can affect safety must be remedied immediately.
Maintenance/Repairs	Control unit function should be checked regularly. Troubleshooting and repairs may only be done by trained personnel. The prescribed electrical protection must be met.
Disposal and recycling	When replacing components or when the control unit must be replaced in its entirety, please follow the advice below: The aim should always be maximum possible recycling of raw materials, with minimum possible environmental impact. Never dispose of electrical components with ordinary waste, always use the designated collection points. Disposal should be effected as environment-friendly as the technology allows in terms of environmental protection and recycling.

## SAFETY INSTRUCTIONS

The following symbols and references will be used in this description. These instructions are important; they apply to personal and technical safety during operation.

	Safety instruction refers to instructions whose specific intent is to avoid the risk of personal injury and to prevent damage to equipment. Be careful of sharp edges during installation and maintenance.
	Danger! Electrical current to electrical components! NB! Switch off main power before removing the cover.  Never touch electrical components or contacts while main current is switched on. Risk of electric shock, resulting in serious injury or death.  Connected terminals contain residual voltage even after the main current has been switched off. All connections may only be made when the equipment is de-energized.
	The metal surfaces of the control unit act as heat sinks that effectively dissipate heat.

## DESCRIPTION OF FUNCTIONS

- The control unit is part of a new range that is adapted, with the necessary additional functions, to optimally control a rotary heat exchanger.  
The series comes in three sizes, VariMax25 NG, VariMax50 NG and VariMax100 NG.  
The control units operate 3-phase stepper motors.  
The control units have a 0-10 V input signal or Modbus.

- The control unit is intended for rotors up to 4000 mm with a max rotor speed of 12 rpm. If the rotor requires a higher rotor speed, rotor diameter should be reduced.

- The control unit has internal Modbus functions.  
For more information, see the manual on our website, [www.ibcccontrol.com](http://www.ibcccontrol.com)

- The control unit has an integrated input signal offset, which means rotor efficiency is proportional to the input signal.

- The control unit threshold is set at 0.1 V (hysteresis 0.13 - 0.07 V). If the input signal drops below this value, the rotor will stop.

- The control unit has an internal rotation monitor. The rotation monitor is protected by patent (EP3961910)

This is activated when the DIP switch for the “External rotation monitor” is in the OFF position.

The internal rotation monitor performs measurements at different times, depending on whether the speed of the motor is above or below 37 rpm.

At a motor speed above 37 rpm, the measurement begins when the speed is stable, normally starting after about 30 seconds, after which measurements are carried out continually. The yellow “Rotation” LED flashes after each completed, approved measurement. The time between the measurements varies from 22 seconds to nearly two minutes.

At a motor speed below 37 rpm, the control unit will increase the speed to 37 rpm at two-hour intervals. At start-up, this measurement will start after 10 minutes.

The speed will remain steady for 2 minutes, while the actual measurement is being performed. To verify the measurement, an additional measurement is conducted 10 minutes later. If both of these measurements are positive, i.e. everything is normal, the next measurement will not take place until two hours later.

This sequence is then repeated with the same time intervals, provided the motor speed is below 37 rpm.

Continued on next page

Continued from previous page

- As an alternative, the control unit can have an external rotation monitor (magnet mounted on the rotor with an associated rotation monitor). This is connected at terminal connections 9 and 10, and the DIP switch for the “External rotation monitor” should be in the ON position.
- If both types of rotation monitor are to be deactivated, an 820 ohm resistor (1% ¼ W) is installed between terminal connections 9 and 10.
- The control unit has a built-in cleaning function. The function can be disconnected via DIP switches.
- The control unit only needs a shielded cable and EMC gland to the motor. Other cables do not need to be shielded or EMC glands.
- The control unit starts automatically when the voltage returns after a power outage. Upon startup, all alarms are reset. 
- The VariMax-motor100 NG is a stepper motor with high torque throughout its speed range.
- The VariMax-motor100 NG has no built-in thermal contact. The control unit regulates power and makes sure the motor will not overheat.
- A holding torque is activated when the motors is stopped, which makes sure the rotor remain static. The holding torque is lost if power to the control unit is cut.
- The motor is mounted with a 3 m cable as standard. The cable must not be spliced.

## MOUNTING



## TECHNICAL DATA, CONTROL UNIT

Connection voltage	1×230-240 V +/-15% 50/60 Hz	Ambient temperature, non condensing	-40 - +40 °C
Power input max	550 W	Ambient temperature during transport and storage	-40 - +60 °C
Input current max	2.5 A	Maximum operating altitude for the control unit	1000 m
Main circuit breaker max	10 A, characteristic C	Protection form	IP44
Output voltage*)	3×0-300 V	Weight	1,9 kg
Output current, max	3.2 A	Dimensions, H×W×D	229×195×90 mm
Output frequency	0-333 Hz		
Acceleration and retardation time	30 sec	*) Exact value cannot be obtained with a digital measuring instrument	

## TECHNICAL DATA, MOTOR

Max moment	10 Nm	Ambient temperature during transport and storage	-40 - +60 °C
Min rpm	1 rpm	Maximum operating altitude for the control unit	1000 m
Max. speed (rpm)	400 rpm	Protection form	IP54
Motor temperature mantle max	110 °C	Weight incl. motor bracket	8.4 kg
Shaft diameter	19 mm	Dimensions incl. shaft and motor bracket H×W×L	142×150×177 mm
Shaft length	35 mm		
Ambient temperature	-30 - +45 °C -40 - +45 °C *)		

\*) Note, The control unit must be connected to power all the time

## FUNCTIONS

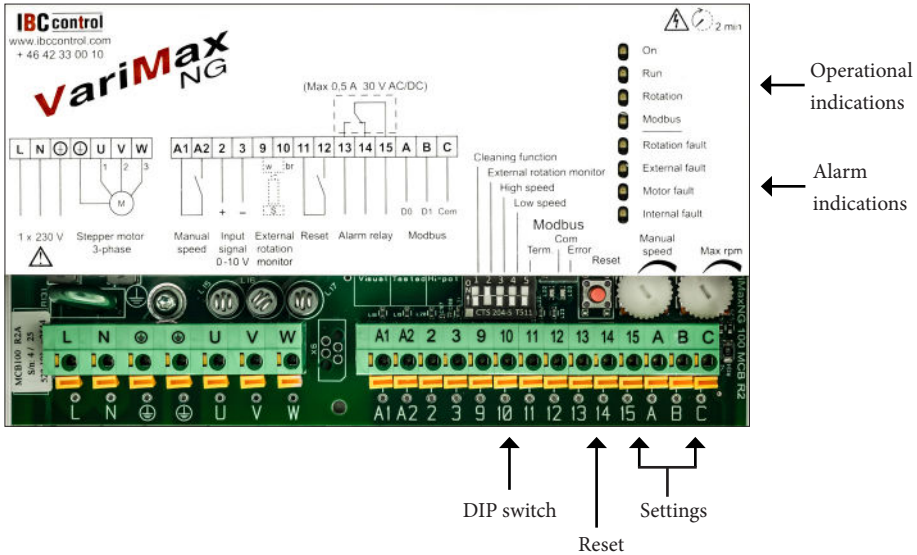

## DIP SWITCH

### Cleaning function

Cleaning function connected in ON position.

When the rotor has stopped for 10 minutes, the cleaning function is activated and the rotor starts to rotate. As advance warning, the rotor rotates with a motor speed of 5 rpm for the first 6 seconds, following which the rotor stops for 3 seconds. After this, the actual cleaning function starts, for a random time, between 10 to 20 seconds with the motor at 20 rpm.

### External rotation monitor

The internal rotation monitor is normally used, in which case the DIP switch must be in the OFF position.

If the external rotation monitor is used, this is connected at terminal connections 9 and 10, in which case the DIP switch must be in the ON position.

### High speed \*)

The rotor rotates at the set max. rpm when the DIP switch is set to ON. After a test run, make sure the DIP switch is set to OFF.

### Low speed \*)

The rotor rotates at the pre-set min speed (1 rpm) when the DIP switch is set to ON. After a test run, make sure the DIP switch is set to OFF.

### Modbus termination

If the control unit is last in the Modbus loop, the DIP switch must be in the ON position.

\*) Manual operation (during test)

## OPERATIONAL INDICATIONS

<b>On</b>	Lit with fixed light It flashes when the control unit has tripped.
<b>Run</b>	Comes on when the motor is to rotate, i.e. when the input signal exceeds the threshold value. Flashes during the cleaning function sequence.
<b>Rotation</b>	
<b>Internal rotation monitor</b>	Flashes after each approved measurement, although only when the “External rotation monitor” DIP switch is in the OFF position; for more information, see “Description of functions” on page 3
<b>External rotation monitor</b>	Flashes when the magnet passes the rotation monitor, regardless of the setting of the “External rotation monitor” DIP switch. Flashes even if the input signal is lower than the threshold value.
<b>Modbus</b>	If Modbus must be used, refer to the separate manual on our website, <a href="http://www.ibccontrol.com">www.ibccontrol.com</a> .

## ALARMS

In the case of an alarm, the control unit will restart after 30 seconds. The relevant red LED will light up for the same period of time (30 seconds). After restart, the LED is extinguished; this takes place twice. The third time, the alarm relay closes and the alarm "moves on". For the alarm relay to close and the alarm to “move on”, the above three alarms must occur within 90 minutes, otherwise the sequence will be reset. The green LED burns steadily for the first and second alarms and only begins to flash for the third alarm. All alarms subsequently remain.

## Rotation fault

<b>Internal rotation monitor</b>	Generates an alarm and trips if two consecutive measurements indicate that the rotor is not rotating. For more information, see “Description of functions” on page 3.
Probable fault cause during installation	<ul style="list-style-type: none"><li>- Broken belt</li><li>- Belt slipping</li><li>- Stuck rotor</li></ul>
<b>External rotation monitor</b>	Generates an alarm and trips if a pulse is not received every 30 minutes at minimum speed (motor 1 rpm), and every 20 seconds at maximum speed (motor 400 rpm). The time between these speeds is linear. The function can be disconnected via DIP switches.
Probable fault cause during installation	<ul style="list-style-type: none"><li>- Magnet turned the wrong way</li><li>- Rotation monitor incorrectly connected (wrong polarity), refer to “Connections” on page 11</li><li>- Too wide a gap between rotation monitor and magnet; max 15 mm</li></ul>
Probable fault cause in operation	<ul style="list-style-type: none"><li>- Broken belt</li><li>- Belt slipping</li><li>- Stuck rotor</li><li>- Rotation monitor or magnet not intact</li></ul>

## External faults

<b>Overvoltage</b>	Alarms and trips if the connection voltage exceeds 276 V.
<b>Undervoltage</b>	Alarms and trips if the connection voltage drops below 195 V.
<b>Over/under temperature</b>	Alarms and trips if the temperature inside the control unit exceeds/drops below safe limits.

## Motor fault

<b>Motor temperature</b>	The control unit regulates power and makes sure the motor will not overheat.
<b>Short circuit</b>	Alarms and trips in the event of short circuit phase-phase or phase-earth.
<b>Probable cause of fault</b>	<ul style="list-style-type: none"><li>- Short circuit between phases in cable or motor</li><li>- Short circuit between phase-earth in cable or motor</li><li>- Interruption to one phase in cable or motor</li><li>- No motor or wrong motor connected</li></ul> Measure the motor resistance; should be equal on all windings.

## Internal fault

<b>Internal fault</b>	Alarms and trips if an internal fault occurs in the control unit.
-----------------------	---

## SETTINGS VIA POTENTIOMETER

<b>Manual speed</b>	By closing A1-A2 the speed is controlled via the potentiometer marked "Manual speed". Can be regulated between 1 and 400 rpm. The rotor rotates at the set speed, whatever the value of the input signal. Factory setting at 11 o'clock (1 rpm on motor shaft).
<b>Max rpm</b>	Potentiometer for adjusting max. speed. Regulates between 50 and 400 rpm. Factory setting at 11 o'clock (50 rpm on motor shaft).

## RESET

<b>Reset</b>	Push button for resetting the control unit. The control unit is also reset in the event of voltage drop-out and closure between terminal 11 and 12.
--------------	---

## EMC-INSTALLATION

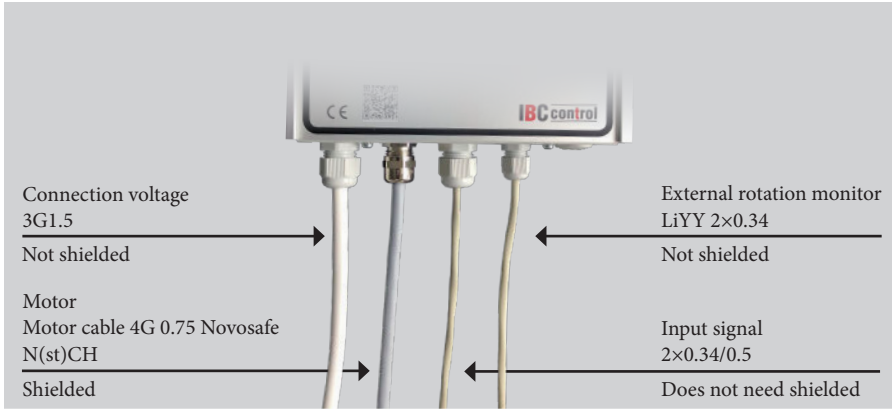

EMC glands must be used for shielded cables.

The above cables or equivalent must be used to comply with the EMC Directive.

## EMC GLAND

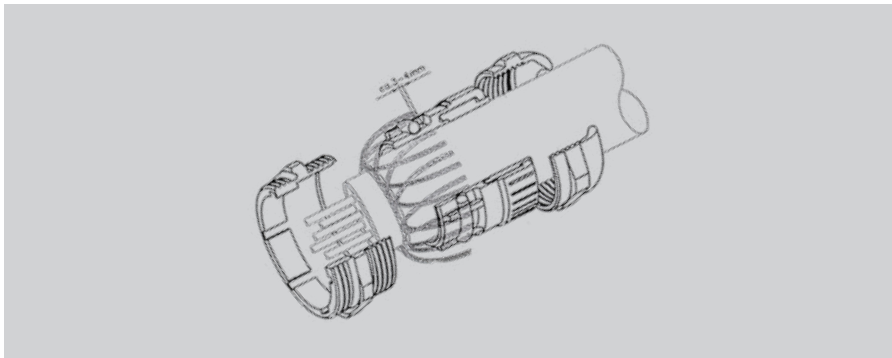

### NOTE!

When connecting the shielding to the EMC gland, it is important to connect as shown above.

## CONNECTION DIAGRAM

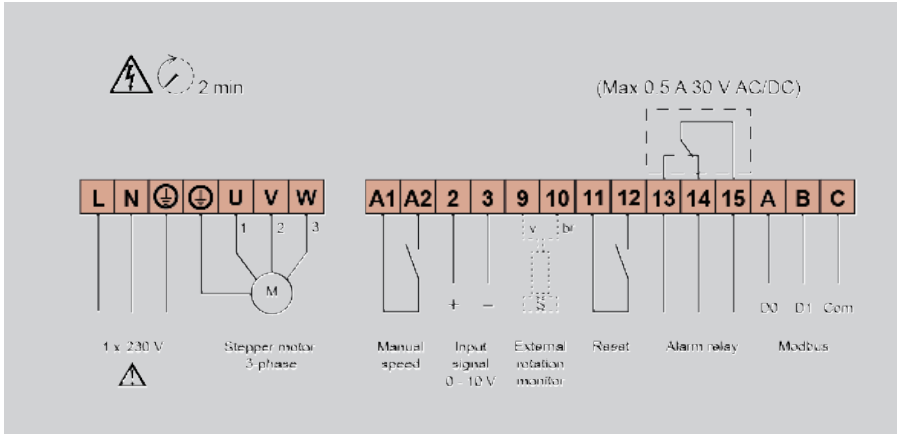

## CONNECTIONS



Switch off power before working on the equipment.

NOTE: Dangerous voltage may be present in the control unit for up to 2 minutes after disconnection and the motor has stopped rotating.

<b>Connection voltage (L-N-PE)</b>	1×230-240 V +/-15%, 50/60 Hz. NOTE! Protective earth must always be connected.
	If the VariMax100 NG is connected phase/phase, no type A residual current circuit breaker may be connected.
<b>Motor (U-V-W)</b>	A VariMax-motor100 NG must be used. Direction of rotation is changed by switching two of the phases.
<b>Manual speed (A1-A2)</b>	Produces set rotation speed on closure.
<b>Input signal (2-3)</b>	0-10 V. Plus connected to terminal 2, minus to terminal 3.

Continued on next page

Continued from previous page

<b>12 V output</b> (3-11)	Output for 12 V DC. Terminal connection 3 is minus (-), terminal connection 11 is plus (+). Max 50 mA.
<b>External rotation monitor</b> (9-10)	If an external rotation monitor is used, this is connected as shown below. White cable connected to terminal 9, brown to terminal 10. The magnet is installed with south side (S) towards the sensor. Max. gap 15 mm.
<b>Reset</b> (11-12)	Remote reset in the event of alarm. The control unit resets automatically when power returns after a power outage.
<b>Alarm relay</b> (13-14-15)	Closes between 14-15 in the event of an alarm or voltage drop-out. Max 0.5 A resistive load / 30 V AC/DC.
<b>Modbus</b> (A-B-C)	If Modbus must be used, refer to the separate manual on our website, <a href="http://www.ibcccontrol.com">www.ibcccontrol.com</a> .

## INPUT SIGNAL/ROTATION SPEED

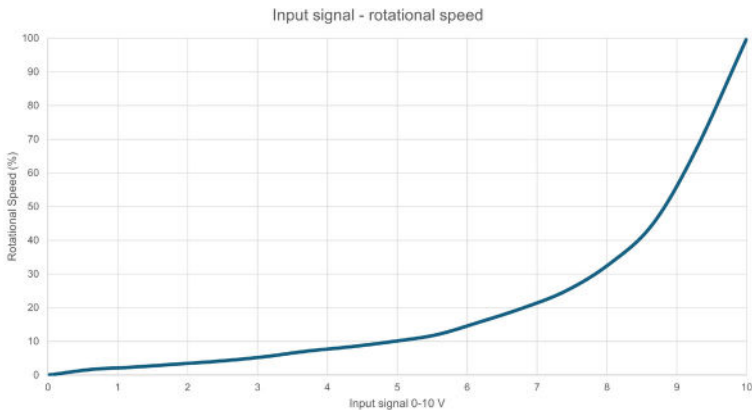

The input signal is directly proportional to the efficiency of the rotor, which means that input signal and rotation speed are as per adjoining diagram.

## CHECKS BEFORE POWERING UP THE CONTROL UNIT



<b>Check that</b>	the control unit is connected as per instructions on page 11. Connection voltage 1x230-240 V +/-15%, 50/60 Hz.
<b>Check that</b>	the input signal is 0-10 V or Modbus.

## PUTTING THE EQUIPMENT INTO OPERATION



Should be done in sequence

<b>Check that</b>	the motor rotates in the right direction in relation to the rotor's direction of rotation. In the event of a fault, switch two phases to the motor.
<b>Adjustment of max. speed</b>	Set the "High Speed" DIP switch to the ON position. Adjust "Max rpm" until the rotor rotates at 10-12 rpm (or as directed by the rotor manufacturer). After a test run, make sure the DIP switch is set to OFF.
<b>Checking minimum speed</b>	Set the "Low Speed" DIP switch to ON. Check that the rotor starts. The minimum speed is pre-set. After a test run, make sure the DIP switch is set to OFF.
<b>Checking the cleaning function</b>	Switch off the voltage. Make sure the "Cleaning function" DIP switch is set to ON and the input signal is disconnected. After switching on the voltage, the cleaning function starts by the rotor rotating for 6 seconds with a motor speed of 5 rpm, after which the rotor stops for 3 seconds. After this, the actual cleaning function starts, for a random time, between 10 to 20 seconds with the motor at 20 rpm
<b>Checking the Internal rotation monitor</b>	The yellow "Rotation" LED will flash following an approved measurement. For more information, see "Description of functions" on page 3.
<b>External rotation monitor</b>	The yellow "Rotation" LED will flash when the magnet passes the rotation monitor, regardless of DIP switch position.
<b>Finish by</b>	having the control unit drive the rotor at maximum and minimum rotation speed and checking that the rotor speed is correct.

F21100905GB  
VERSION 1.0  
2026-05-01

**IBC**control

IBC control AB  
Brännerigatan 5 A  
SE-263 37 Höganäs  
Sweden  
Tel. +46 42 33 00 10  
[www.ibcccontrol.com](http://www.ibcccontrol.com)  
[info@ibcccontrol.se](mailto:info@ibcccontrol.se)